

A1000 6-Phase/12-Pulse Input Flange Mount and Non-Flange Mount Installation Manual

Type: CIMR-AU4T A and CIMR-AU4T U
Models: 400 V Class: 30 to 355 kW (40 to 550 HP ND)

To properly use the product, read this manual thoroughly and retain for easy reference, inspection, and maintenance. Ensure the end user receives this manual.

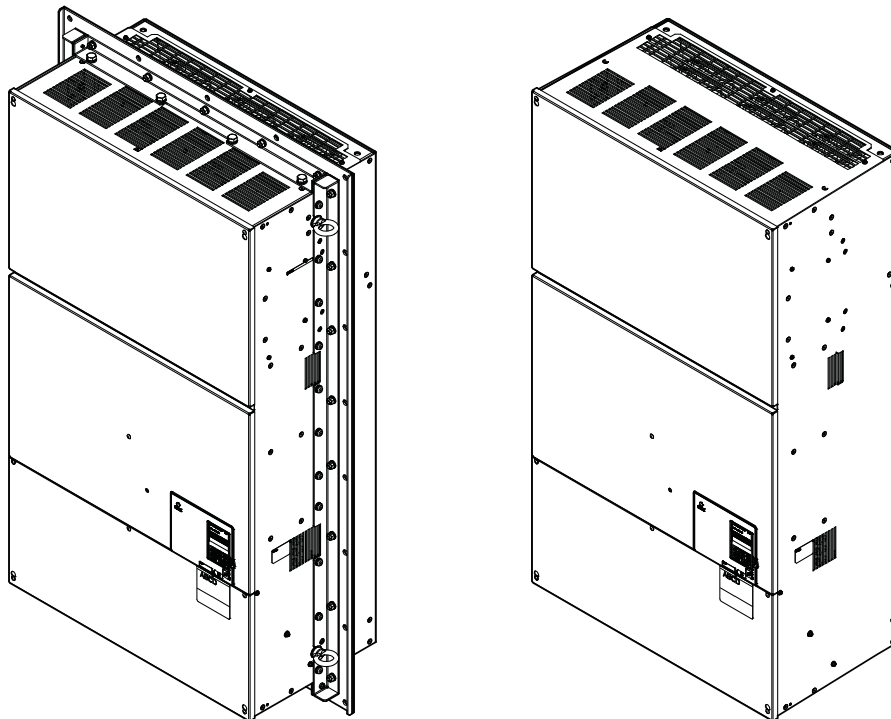

Copyright © 2015 YASKAWA AMERICA, INC. All rights reserved.

No part of this publication may be reproduced, stored in a retrieval system, or transmitted, in any form or by any means, mechanical, electronic, photocopying, recording, or otherwise, without the prior written permission of Yaskawa. No patent liability is assumed with respect to the use of the information contained herein. Moreover, because Yaskawa is constantly striving to improve its high-quality products, the information contained in this manual is subject to change without notice. Every precaution has been taken in the preparation of this manual. Yaskawa assumes no responsibility for errors or omissions. Neither is any liability assumed for damages resulting from the use of the information contained in this publication.

Preface

1	PREFACE.....	4
---	--------------	---

1 Preface

Yaskawa manufactures products used as components in a wide variety of industrial systems and equipment. The selection and application of Yaskawa products remain the responsibility of the equipment manufacturer or end user. Yaskawa accepts no responsibility for the way its products are incorporated into the final system design. Under no circumstances should any Yaskawa product be incorporated into any product or design as the exclusive or sole safety control. Without exception, all controls should be designed to detect faults dynamically and fail safely under all circumstances. All systems or equipment designed to incorporate a product manufactured by Yaskawa must be supplied to the end user with appropriate warnings and instructions as to the safe use and operation of that part. Any warnings provided by Yaskawa must be promptly provided to the end user. Yaskawa offers an express warranty only as to the quality of its products in conforming to standards and specifications published in the Yaskawa manual. **NO OTHER WARRANTY, EXPRESS OR IMPLIED, IS OFFERED.** Yaskawa assumes no liability for any personal injury, property damage, losses, or claims arising from misapplication of its products.

This manual is designed to ensure correct and suitable application of A1000-Series Drives with 6-Phase/12-Pulse rectification. Read this manual before attempting to install or operate a drive and keep it in a safe, convenient location for future reference. Be sure you understand all precautions and safety information before attempting application.

Use this manual as the primary reference to install and wire A1000 drives with 6-Phase/12-Pulse rectification together with the A1000 Quick Start Guide and Technical Manual.

◆ Product Overview

The A1000 6-Phase/12-Pulse drive design matches an isolation transformer with a tuned input reactor to provide a phase shift that reduces harmonic distortion for cleaner power.

◆ Applicable Documentation

The following manuals are available for A1000 series drives:

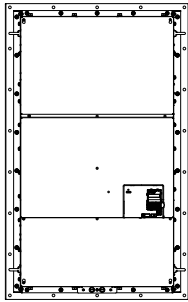
	A1000 Series AC Drive 6-Phase/12-Pulse Input Installation Manual (TOEPYAIA1U02) This guide is packaged together with the product and contains information required to install and wire the drive with 6-Phase/12-Pulse rectification. This manual is available for download on our documentation website, www.yaskawa.com .
	A1000 Series AC Drive Quick Start Guide (TOEPC71061641) This guide contains basic information required to install and wire the 3-Phase/6-Pulse drive and gives an overview of fault diagnostics, maintenance, and parameter settings for 3-Phase/6-Pulse and 6-Phase/12-Pulse drives. The purpose of this guide is to prepare the drive for a trial run with an application and for basic operation. This manual is available for download on our documentation website, www.yaskawa.com .
	A1000 Series AC Drive Technical Manual (SIEPC71061641) This manual provides detailed information on 3-Phase/6-Pulse and 6-Phase/12-Pulse parameter settings, drive functions, and MEMOBUS/Modbus specifications. Use this manual to expand drive functionality and to take advantage of higher performance features. This manual is available for download on our documentation website, www.yaskawa.com .

◆ Supplemental Safety Information

General Precautions

- The diagrams in this manual may be indicated without covers or safety shields to show details. Replace the covers or shields before operating the drive and run the drive according to the instructions described in this manual.
- Any illustrations, photographs, or examples used in this manual are provided as examples only and may not apply to all products to which this manual is applicable.
- The products and specifications described in this manual or the content and presentation of the manual may be changed without notice to improve the product and/or the manual.
- When ordering a new copy of the manual due to damage or loss, contact your Yaskawa representative or the nearest Yaskawa sales office and provide the manual number shown on the front cover.
- If nameplate becomes worn or damaged, order a replacement from your Yaskawa representative or the nearest Yaskawa sales office.

WARNING

Read and understand this manual before installing, operating or servicing this drive. The drive must be installed according to this manual and local codes.

⚠ WARNING

The following conventions are used to indicate safety messages in this manual. Failure to heed these messages could result in serious or fatal injury or damage to the products or to related equipment and systems.

⚠ DANGER

Indicates a hazardous situation, which, if not avoided, will result in death or serious injury.

⚠ WARNING

Indicates a hazardous situation, which, if not avoided, could result in death or serious injury.

WARNING! may also be indicated by a bold key word embedded in the text followed by an italicized safety message.

⚠ CAUTION

Indicates a hazardous situation, which, if not avoided, could result in minor or moderate injury.

CAUTION! may also be indicated by a bold key word embedded in the text followed by an italicized safety message.

NOTICE

Indicates a property damage message.

NOTICE: may also be indicated by a bold key word embedded in the text followed by an italicized safety message.

◆ Safety Messages**⚠ DANGER**

Heed the safety messages in this manual.

Failure to comply will result in death or serious injury.

The operating company is responsible for any injuries or equipment damage resulting from failure to heed the warnings in this manual.

Electrical Shock Hazard

Before servicing, disconnect all power to the equipment.

The capacitor for the control power supply remains charged even after the power supply is turned off. The charge indicator LED will extinguish when the control power supply voltage is below 50 Vdc. To prevent electric shock, wait for at least the time specified on the warning label, once all indicators are OFF, measure for unsafe voltages to confirm the drive is safe prior to servicing.

Failure to comply will result in death or serious injury.

⚠ WARNING**Sudden Movement Hazard**

System may start unexpectedly upon application of power, resulting in death or serious injury.

Clear all personnel from the drive, motor and machine area before applying power. Secure covers, couplings, shaft keys and machine loads before applying power to the drive.

WARNING

Electrical Shock Hazard

Do not attempt to modify or alter the drive in any way not explained in this manual.

Failure to comply could result in death or serious injury.

Yaskawa is not responsible for any modification of the product made by the user. This product must not be modified.

Do not allow unqualified personnel to use equipment.

Failure to comply could result in death or serious injury.

Installation, maintenance, inspection, and service must be performed only by authorized personnel familiar with installation, adjustment and maintenance of AC drives.

Do not remove covers or touch circuit boards while the power is on.

Failure to comply could result in death or serious injury.

Make sure the protective earthing conductor complies with technical standards and local safety regulations.

Because the leakage current exceeds 3.5 mA in models 4□0302 and larger, IEC/EN 61800-5-1 states that either the power supply must be automatically disconnected in case of discontinuity of the protective earthing conductor or a protective earthing conductor with a cross-section of at least 10 mm² (Cu) or 16 mm² (Al) must be used. Failure to comply may result in death or serious injury.

Always use appropriate equipment for Ground Fault Circuit Interrupters (GFCIs).

The drive can cause a residual current with a DC component in the protective earthing conductor. Where a residual current operated protective or monitoring device is used for protection in case of direct or indirect contact, always use a type B GFCI according to IEC/EN 60755.

Fire Hazard

Do not use an improper voltage source.

Failure to comply could result in death or serious injury by fire.

Verify that the rated voltage of the drive matches the voltage of the incoming power supply before applying power.

Install adequate branch circuit protection according to applicable local codes and this Installation Manual. Failure to comply could result in fire and damage to the drive or injury to personnel.

The device is suitable for use on a circuit capable of delivering not more than 100,000 RMS symmetrical amperes, 480 Vac maximum (400 V class), when protected by branch circuit protection devices specified in this manual.

Crush Hazard

Do not use this drive in lifting applications without installing external safety circuitry to prevent accidental dropping of the load.

The drive does not possess built-in load drop protection for lifting applications.

Failure to comply could result in death or serious injury from falling loads.

Install electrical and/or mechanical safety circuit mechanisms independent of drive circuitry.

CAUTION

Crush Hazard

Do not carry the drive by the front cover.

Failure to comply may result in minor or moderate injury from the main body of the drive falling.

NOTICE

Observe proper electrostatic discharge procedures (ESD) when handling the drive and circuit boards. Failure to comply may result in ESD damage to the drive circuitry.

Do not perform a withstand voltage test on any part of the drive.

Failure to comply could result in damage to the sensitive devices within the drive.

Do not operate damaged equipment.

Failure to comply could result in further damage to the equipment. Do not connect or operate any equipment with visible damage or missing parts.

If a fuse is blown or a Ground Fault Circuit Interrupter (GFCI) is tripped, check the wiring and the selection of the peripheral devices.

Contact your supplier if the cause cannot be identified after checking the above.

Do not restart the drive immediately operate the peripheral devices if a fuse is blown or a GFCI is tripped.

Check the wiring and the selection of peripheral devices to identify the cause. Contact your supplier before restarting the drive or the peripheral devices if the cause cannot be identified.

Do not expose the drive to halogen group disinfectants.

Failure to comply may cause damage to the electrical components in the drive.

Do not pack the drive in wooden materials that have been fumigated or sterilized. Do not sterilize the entire package after the product is packed.

■ General Application Precautions

Selection

Installing a Transformer

Install a 6-Phase/12-Pulse isolation transformer with each of the output windings phase shifted by 30 electrical degrees or install a Hybrid 6-Phase topology on the power supply.

Installing a Reactor

Use an AC reactor or DC link choke in the following situations:

- to suppress harmonic current.
- to smooth peak current that results from capacitor switching.
- when the power supply is above 600 kVA.
- when the drive is running from a power supply system with thyristor converters.

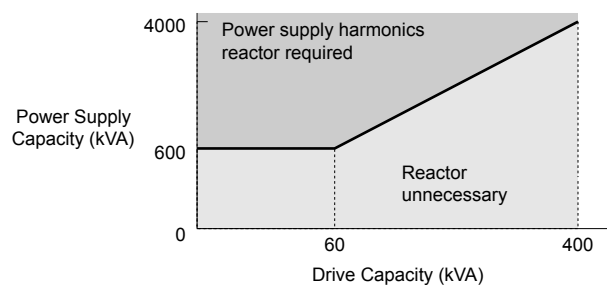

Figure Installing a Reactor

Inspection and Maintenance

WARNING! Electrical Shock Hazard. Capacitors for the control power supply do not immediately discharge after shutting off the power. Wait for at least the amount of time specified on the drive before touching any components after shutting off the power. Failure to comply may cause injury to personnel from electrical shock.

WARNING! Electrical Shock Hazard. When a drive is running a PM motor, voltage continues to be generated at the motor terminals after the drive is shut off while the motor coasts to stop. Take the precautions described below to prevent shock and injury:

- In applications where the machine can still rotate after the drive has fully stopped a load, install a switch to the drive output side to disconnect the motor and the drive.
- Do not allow an external force to rotate the motor beyond the maximum allowable speed or to rotate the motor when the drive has been shut off.
- Wait for at least the time specified on the warning label after opening the load switch on the output side before inspecting the drive or performing any maintenance.
- Do not open and close the load switch while the motor is running.
- If the motor is coasting, make sure the power to the drive is turned on and the drive output has completely stopped before closing the load switch.

WARNING! Burn Hazard. Because the heatsink can get very hot during operation, take proper precautions to prevent burns. When replacing the cooling fan, shut off the power and wait at least 15 minutes to be sure that the heatsink has cooled down. Failure to comply may cause burn injury to personnel.

Wiring

All wire ends should use ring terminals for UL/cUL compliance. Use only the tools recommended by the terminal manufacturer for crimping.

Transporting the Drive

NOTICE: Never steam clean the drive. During transport, keep the drive from coming into contact with salts, fluorine, bromine, phthalate ester, and other such harmful chemicals.

◆ Drive Label Warning Example

Always heed the warning information listed in *Figure* .

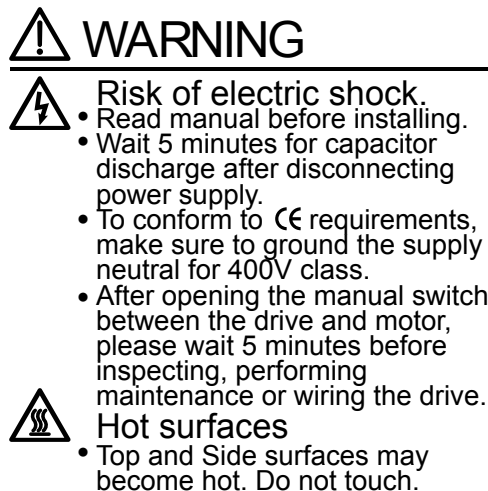

WARNING

- Risk of electric shock.
 - Read manual before installing.
 - Wait 5 minutes for capacitor discharge after disconnecting power supply.
 - To conform to **CE** requirements, make sure to ground the supply neutral for 400V class.
 - After opening the manual switch between the drive and motor, please wait 5 minutes before inspecting, performing maintenance or wiring the drive.
- Hot surfaces
 - Top and Side surfaces may become hot. Do not touch.

Figure Warning Information Example

◆ Warranty Information

■ Restrictions

The drive is not designed or manufactured for use in devices or systems that may directly affect or threaten human lives or health.

Customers who intend to use the product described in this manual for devices or systems relating to transportation, health care, space aviation, atomic power, electric power, or in underwater applications must first contact their Yaskawa representatives or the nearest Yaskawa sales office.

WARNING! Injury to Personnel. This product has been manufactured under strict quality-control guidelines. However, if this product is to be installed in any location where failure of this product could involve or result in a life-and-death situation or loss of human life or in a facility where failure may cause a serious accident or physical injury, safety devices must be installed to minimize the likelihood of any accident.

Installation Manual

1	RECEIVING.....	10
2	MECHANICAL INSTALLATION.....	13
3	ELECTRICAL INSTALLATION.....	15
4	START-UP PROGRAMMING & OPERATION.....	26
5	TROUBLESHOOTING.....	27
6	DRIVE OPTIONS AND PERIPHERAL DEVICES.....	29
7	PERIODIC INSPECTION & MAINTENANCE.....	35
8	SPECIFICATIONS.....	38
9	PARAMETER TABLE.....	77
10	STANDARDS COMPLIANCE.....	81

1 Receiving

◆ Model Number and Nameplate Check

Please perform the following tasks after receiving the drive:

- Inspect the drive for damage.
If the drive appears damaged upon receipt, contact the shipper immediately.
- Verify receipt of the correct model by checking the information on the nameplate.
- If you have received the wrong model or the drive does not function properly, contact your supplier.

◆ Nameplate

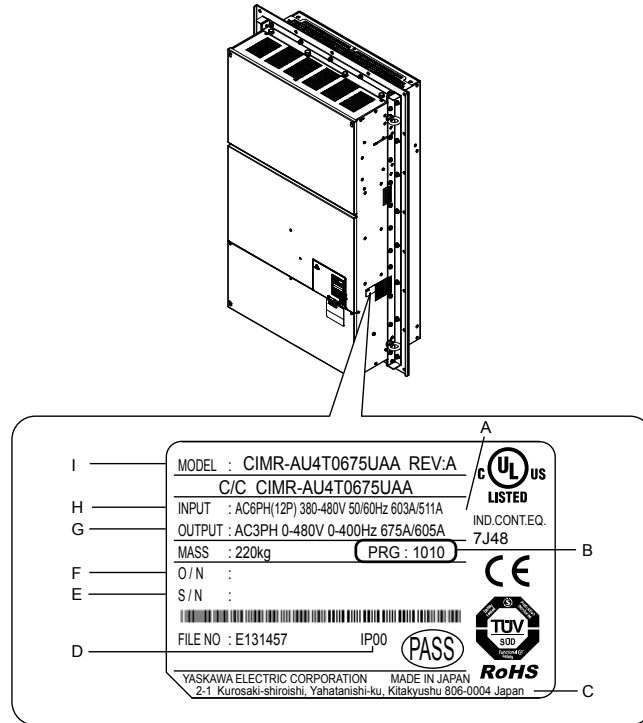

- | | |
|------------------------------------------|----------------------------------|
| A – Normal Duty / Heavy Duty Amps | F – Lot number |
| B – Software version | G – Output specifications |
| C – Address <1> | H – Input specifications |
| D – Enclosure type | I – AC drive model |
| E – Serial number | |

Figure 1 Nameplate Information Example

<1> The address of the head office of Yaskawa Electric Corporation (responsible for product liability) is shown on the nameplate.

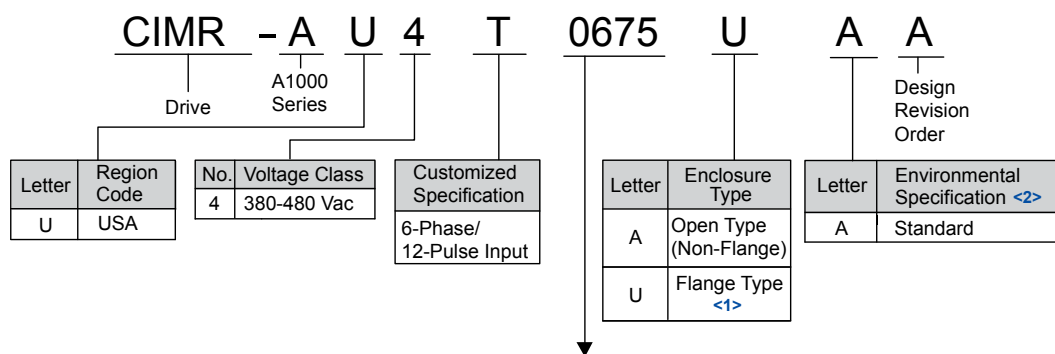

Refer to the tables below

- <1> Provides method of mounting drive with backside (heatsink) external to enclosure with NEMA 12 integrity.
- <2> Drives with these specifications do not guarantee complete protection for the environmental conditions indicated.

■ **6-Phase/12-Pulse 400 V Class Rated Output**

Table 1 Model Number and Specifications (400 V Class)

Normal Duty (ND) C6-01 = 1			Heavy Duty (HD) C6-01 = 0		
Drive Model	Max. Motor Capacity kW (HP)	Rated Output Current A	Drive Model	Max. Motor Capacity kW (HP)	Rated Output Current A
4T0058□	30 (40)	58	4T0058□	22 (25-30)	45
4T0072□	37 (50)	72	4T0072□	30 (40)	60
4T0088□	45 (60)	88	4T0088□	37 (50-60)	75
4T0103□	55 (75)	103	4T0103□	45 (50-60)	91
4T0139□	75 (100)	139	4T0139□	55 (75)	112
4T0165□	90 (125)	165	4T0165□	75 (100)	150
4T0208□	110 (150)	208	4T0208□	90 (125-150)	180
4T0250□	132 (200)	250	4T0250□	110 (150)	216
4T0296□	160 (250)	296	4T0296□	132 (200)	260
4T0362□	185 (300)	362	4T0362□	160 (250)	304
4T0414□	220 (350)	414	4T0414□	185 (300)	370
4T0515□	250 (400-450)	515	4T0515□	220 (350)	450
4T0675□	355 (500-550)	675	4T0675□	315 (400-450-500)	605

◆ 6-Phase/12-Pulse Component Names

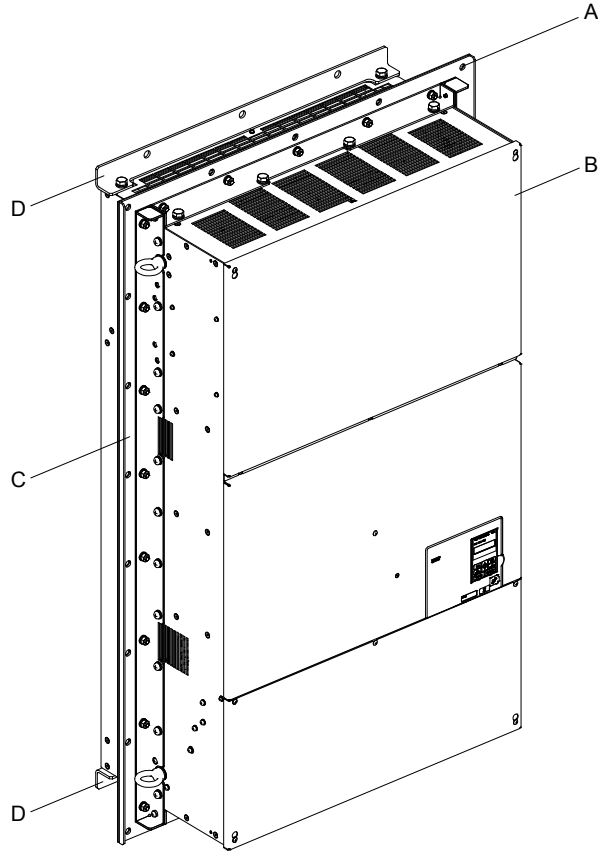

A – Installation hole
B – 6-Phase/12-Pulse Drive

C – Mounting flange <1>
D – Shipping package attachment (to be removed before installation)

Figure 2 Flange Type Enclosure Example (Models 4T□□□□U)

<1> Provides method of mounting drive with backside (heatsink) external to enclosure with NEMA 12 integrity. 4T□□□□U models only.

NOTICE: Remove the shipping package attachments before installing. The shipping package attachments will interfere with the cutting of the panel when installing the drive.

2 Mechanical Installation

This section outlines specifications, procedures, and the environment for proper mechanical installation of the drive.

◆ Installation Environment

Install the drive in an environment matching the specifications in [Table 2](#) to help prolong the optimum performance life of the drive.

Table 2 Installation Environment

Environment	Conditions
Installation Area	Indoors
Ambient Temperature	Flange Type Enclosure: -10 °C to +40 °C (14 °F to 104 °F) Non-Flange Type Enclosure: -10 °C to +50 °C (14 °F to 122 °F) Drive reliability improves in environments without wide temperature fluctuations. When using the drive in an enclosure panel, install a cooling fan or air conditioner in the area to ensure that the air temperature inside the enclosure does not exceed the specified levels. Do not allow ice to develop on the drive.
Humidity	95% RH or less and free of condensation
Storage Temperature	-20 °C to +60 °C
Surrounding Area	Install the drive in an area free from: <ul style="list-style-type: none"> • oil mist and dust • metal shavings, oil, water, or other foreign materials • radioactive materials • combustible materials (e.g., wood) • harmful gases and liquids • excessive vibration • chlorides • direct sunlight.
Altitude	Up to 1000 m without derating, up to 3000 m with output current and voltage derating.
Vibration	10 Hz to 20 Hz at 9.8 m/s ² 20 Hz to 55 Hz at 5.9 m/s ² (Models 4T0058□ to 4T0165□) or 2.0 m/s ² (Models 4T0208□ to 4T0675□)
Orientation	Install the drive vertically to maintain maximum cooling effects.

NOTICE: Avoid placing drive peripheral devices, transformers, or other electronics near the drive as the noise created can lead to erroneous operation. If such devices must be used in close proximity to the drive, take proper steps to shield the drive from noise.

NOTICE: Damage to Equipment. Drive heatsink air outlet temperature may be over 80 °C. Do not install components above the air outlet that may be damaged by 80 °C air temperature.

NOTICE: Damage to Equipment. Prevent foreign matter such as metal shavings and wire clippings from falling into the drive during installation. Failure to comply could result in damage to the drive. Place a temporary cover over the top of the drive during installation. Remove the temporary cover before drive start-up, as the cover will reduce ventilation and cause the drive to overheat.

◆ Removing the Shipping Package Attachments

Remove the shipping package attachments before installation.

Note: The number of screws varies in accordance with the drive model.

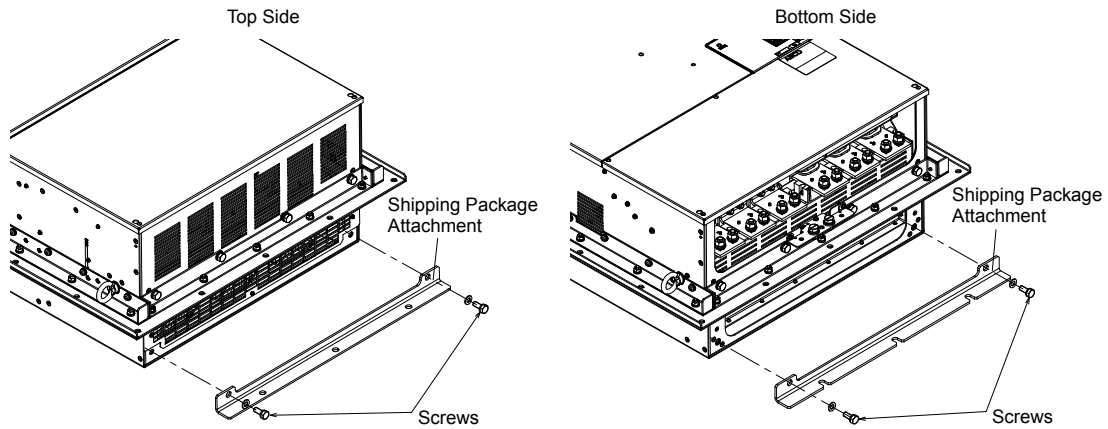

Figure 3 Removing the Shipping Package Attachments

◆ Exterior and Mounting Dimensions

Refer to *External Mounting and Panel Cutout Dimensions on page 44* for 6-phase/12-pulse exterior and mounting dimensions.

◆ Weights

Table 3 Drive Weights

Drive Model	4T0058□	4T0072□	4T0088□	4T0103□	4T0139□	4T0165□	4T0208□	4T0250□	4T0296□	4T0362□	4T0414□	4T0515□	4T0675□
Drive Weight kg (lb)	21 (46.2)	24 (52.8)	35 (77.0)	35 (77.0)	39 (85.8)	40 (88.2)	78 (172)	90 (198)	95 (209)	97 (214)	127 (280)	210 (463)	215 (474)

3 Electrical Installation

◆ Standard Connection Diagram

Connect the drive and peripheral devices as shown in [Figure 4](#). It is possible to set and run the drive via the digital operator without connecting digital I/O wiring.

WARNING! Fire Hazard - Drive Short-Circuit Current Rating. Install adequate branch circuit protection according to applicable local codes and this manual. Failure to comply could result in fire and damage to the drive or injury to personnel. The device is suitable for use on a circuit capable of delivering not more than 100,000 RMS symmetrical amperes, 480 Vac maximum (400 V class), when protected by branch circuit protection devices specified in this manual.

NOTICE: Route motor leads U/T1, V/T2, and W/T3 separate from all other leads to reduce possible interference related issues. Failure to comply may result in abnormal operation of drive and nearby equipment.

NOTICE: Equipment Hazard. Standard motors used with PWM drives may experience winding failures due to surge voltages when input line voltage is greater than 480 V or motor wire distance is greater than 100 meters. Select a motor design with insulation tolerant of surge voltages, such as drive-rated motor for use with PWM drives. Failure to comply could lead to motor winding failure.

Note: The minimum load for the relay outputs M1-M2, M3-M4, M5-M6, and MA-MB-MC is 10 mA.

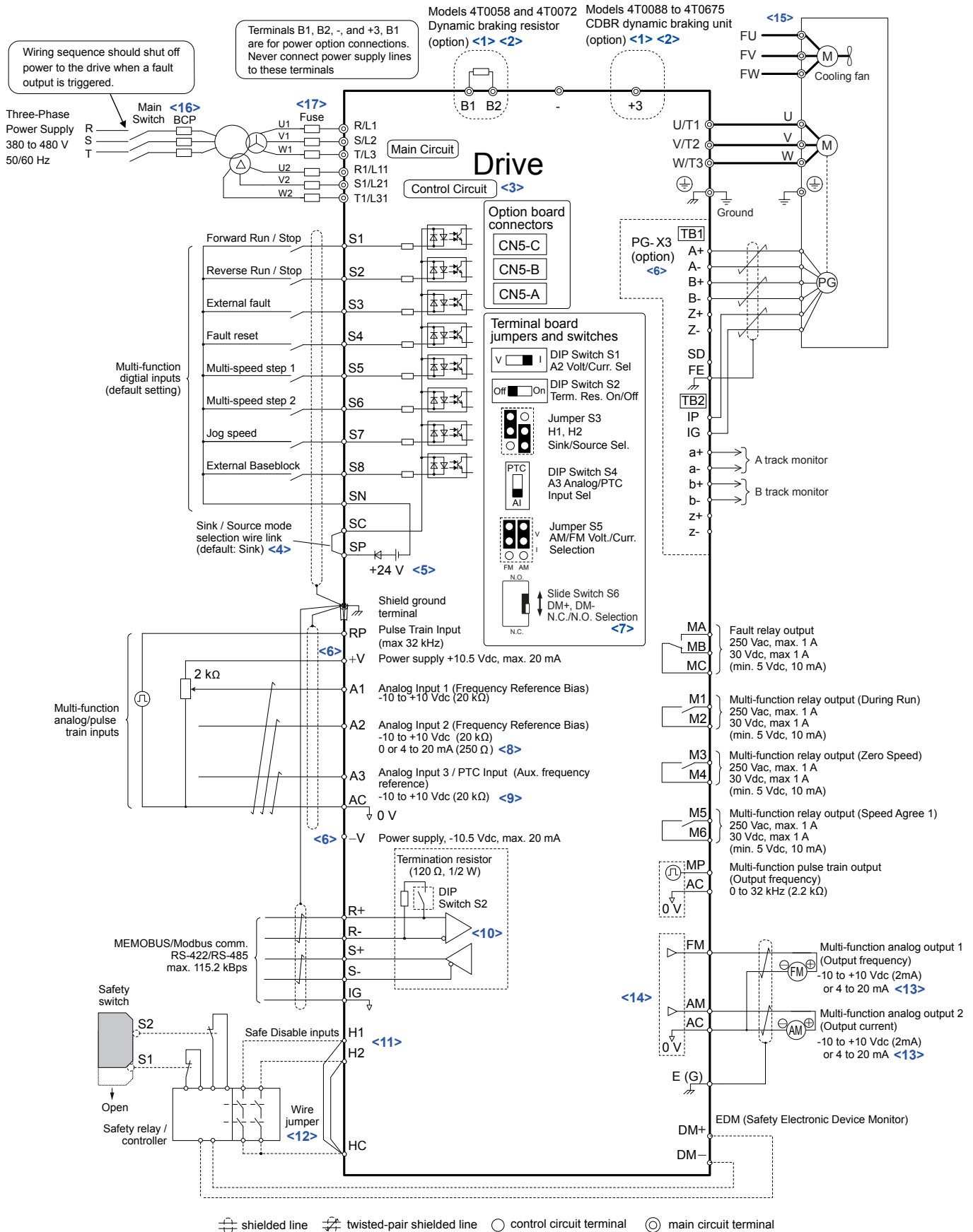

Figure 4 Drive Standard Connection Diagram

- <1> Set up a thermal relay sequence to disconnect drive main power in the event of an overheat condition on the dynamic braking option.
- <2> Set L8-55 to 0 to disable the protection function of the built-in braking transistor of the drive when using an optional regenerative converter or dynamic braking option. Leaving L8-55 enabled may cause a braking resistor fault (rF). Additionally, disable Stall Prevention (L3-04 = 0) when using an optional regenerative converter, regenerative or braking units, or dynamic braking option. Leaving If L3-04 enabled may prevent the drive from stopping within the specified deceleration time.
- <3> Supplying power to the control circuit separately from the main circuit requires 24 V power supply (option).
- <4> This figure illustrates an example of a sequence input to S1 through S8 using a non-powered relay or an NPN transistor. Install the wire link between terminals SC-SP for Sink mode, between SC-SN for Source mode, or leave the link out for external power supply. Never short terminals SP and SN, as it will damage the drive.
- <5> This voltage source supplies a maximum current of 150 mA when not using a digital input card DI-A3.
- <6> The maximum output current capacity for the +V and -V terminals on the control circuit is 20 mA. Never short terminals +V, -V, and AC, as it can cause erroneous operation or damage the drive.
- <7> Slide switch S6 selects N.C. or N.O. as the state of the DM+ and DM- terminals for EDM output. Slide switch S6 is available on terminal board ETC74030□.
- <8> Set DIP switch S1 to select between a voltage or current input signal to terminal A2. The default setting is for current input.
- <9> Set DIP switch S4 to select between analog or PTC input for terminal A3.
- <10> Set DIP switch S2 to the ON position to enable the termination resistor in the last drive in a MEMOBUS/Modbus network.
- <11> Use jumper S3 to select between Sink mode, Source mode, and external power supply for the Safe Disable inputs.
- <12> Disconnect the wire jumper between H1 - HC and H2 - HC when utilizing the Safe Disable input.
- <13> Monitor outputs work with devices such as analog frequency meters, ammeters, voltmeters, and wattmeters. They are not intended for use as a feedback-type signal.
- <14> Use jumper S5 to select between voltage or current output signals at terminals AM and FM. Set parameters H4-07 and H4-08 accordingly.
- <15> Self-cooling motors do not require the same wiring necessary for motors with cooling fans.
- <16> Refer to local codes for proper branch circuit protection (BCP) on the primary side of the 6-Phase/12-Pulse transformer.
- <17> Fuse selection for the secondary side is of the 6-Phase/12-Pulse transformer is shown in [Table 13](#) and [Table 14](#).

WARNING! Sudden Movement Hazard. Do not close the wiring for the control circuit unless the multifunction input terminal parameters are properly set. Improper sequencing of run/stop circuitry could result in death or serious injury from moving equipment.

WARNING! Sudden Movement Hazard. Ensure start/stop and safety circuits are wired properly and in the correct state before energizing the drive. Failure to comply could result in death or serious injury from moving equipment. When programmed for 3-Wire control, a momentary closure on terminal S1 may cause the drive to start.

WARNING! Sudden Movement Hazard. When using a 3-Wire sequence, set the drive to 3-Wire sequence prior to wiring the control terminals and set parameter b1-17 to 0 so the drive will not accept a Run command at power up (default). If the drive is wired for a 3-Wire sequence but set up for a 2-Wire sequence (default), and parameter b1-17 is set to 1 so the drive accepts a Run command at power up, the motor will rotate in reverse direction at drive power up and may cause injury.

WARNING! Sudden Movement Hazard. Confirm the drive I/O signals and external sequence before executing the application preset function. Executing the application preset function or setting A1-06 ≠ 0 will change the drive I/O terminal functions and may cause unexpected equipment operation. Failure to comply may cause death or serious injury.

NOTICE: When using the automatic fault restart function with wiring designed to shut off the power supply upon drive fault, make sure the drive does not trigger a fault output during fault restart (L5-02 = 0, default). Failure to comply will prevent the automatic fault restart function from working properly.

◆ Main Circuit Connection Diagram

Refer to *Figure 5*, *Figure 6*, and *Figure 7* when wiring the main circuit of the drive. Connections may vary based on drive capacity.

NOTICE: Do not use the negative DC bus terminal “e” as a ground terminal. This terminal is at high DC voltage potential. Improper wiring connections could damage the drive.

■ 6-Phase/12-Pulse Input 400 V Class Models 4T0058□ and 4T0072□

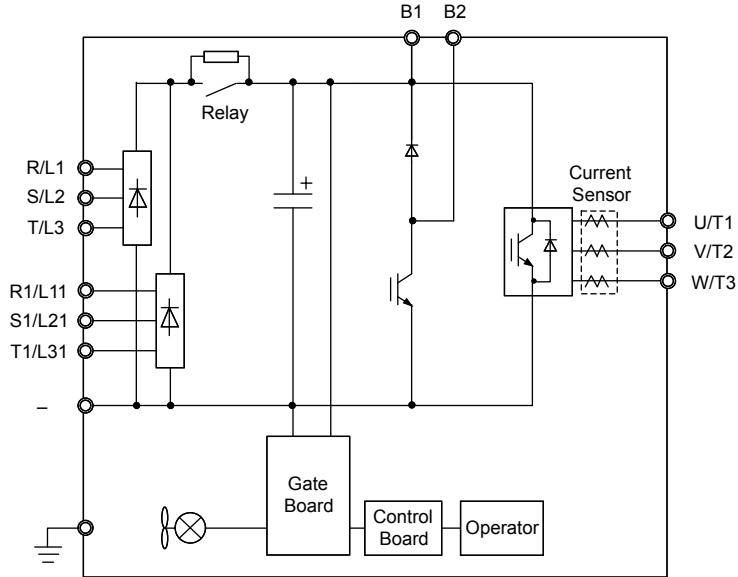

Figure 5 Connecting Main Circuit Terminals

■ 6-Phase/12-Pulse Input 400 V Class Models 4T0088□ to 4T0139□

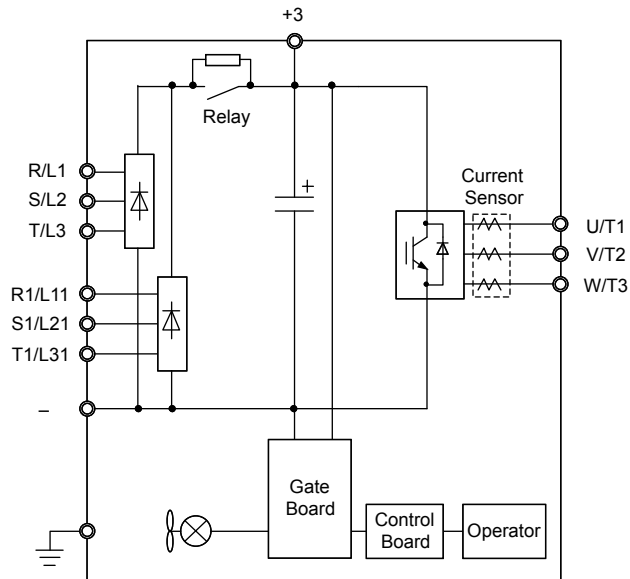

Figure 6 Connecting Main Circuit Terminals

■ 6-Phase/12-Pulse Input 400 V Class Models 4T0165□ to 4T0675□

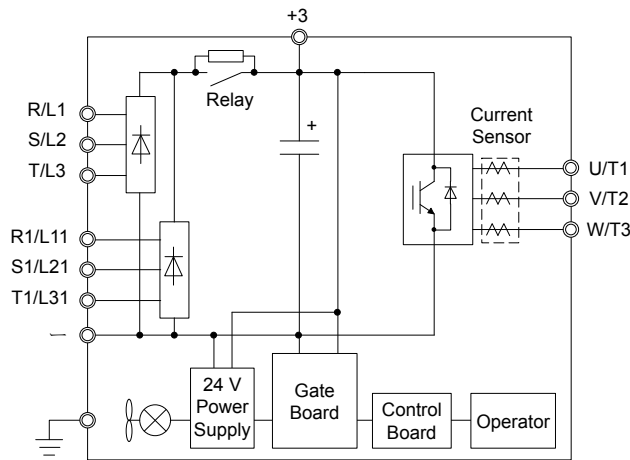

Figure 7 Connecting Main Circuit Terminals

■ 6-Phase/12-Pulse Rectification

Installing a Transformer

Install a 6-Phase/12-Pulse isolation transformer with output windings phase-shifted by 30 electrical degrees or install a Hybrid 6-Phase topology on the power supply.

Installing a 3-Phase Line Monitor

Yaskawa requires installation of a 3-Phase line monitor to protect the drive in the event of an input line phase loss.

The 3-Phase line monitor must be installed on the primary circuit of the 6-Phase/12-Pulse transformer and connected to the drive to remove the Run command when a phase loss condition occurs.

The drive power circuit may be damaged during a phase-loss condition if a 3-Phase line monitor is not properly installed.

Contact a Yaskawa representative for help selecting the optimum 3-Phase line monitor and fuses.

Connection Diagram

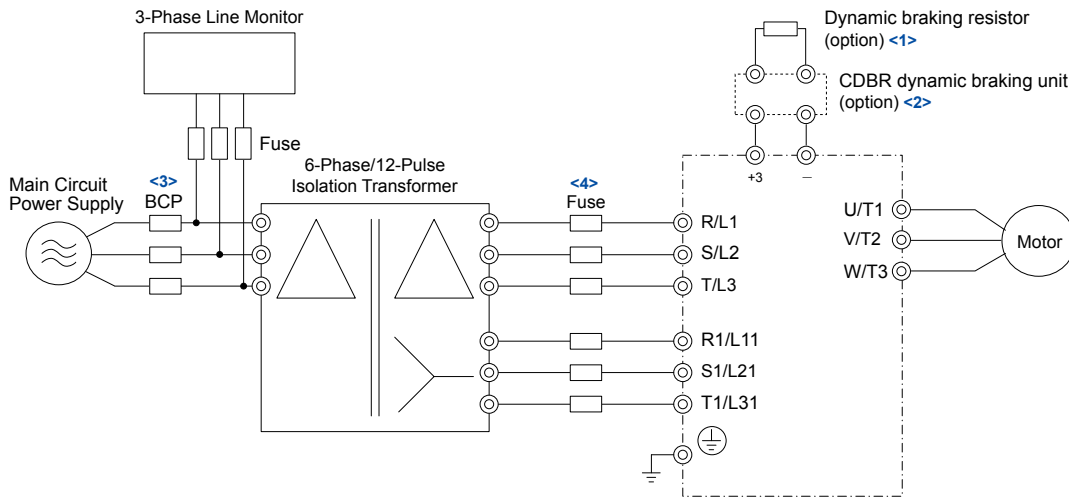

Figure 8 Main Circuit Terminal Connections

<1> A dynamic braking resistor can be connected to the B1 and B2 terminals on models 4T0058□ and 4T0072□.

<2> A CDBR dynamic braking unit cannot be connected to models 4T0058□ or 4T0072□.

<3> Refer to local codes for proper branch circuit protection (BCP) on the primary side of the 6-Phase/12-Pulse transformer.

<4> Fuse selection for the secondary side of the 6-Phase/12-Pulse transformer is shown in [Table 13](#) and [Table 14](#)

◆ Terminal Specifications

Figure 9 to Figure 15 show the different terminal arrangements for the drive capacities.

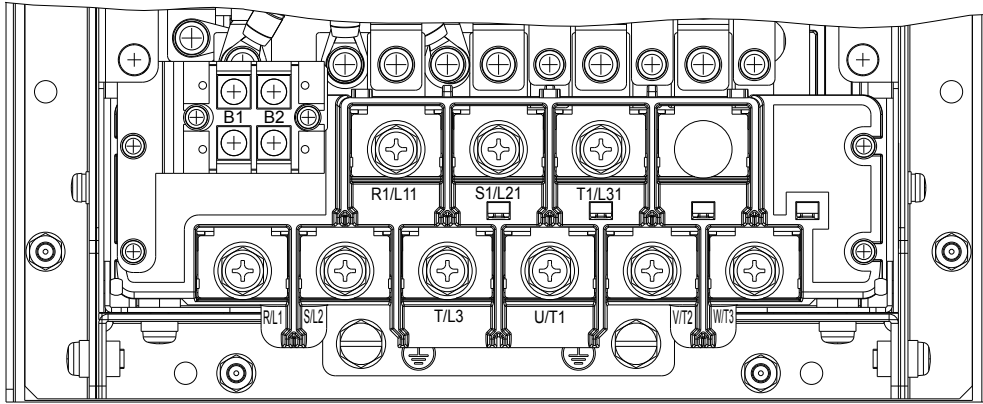

Figure 9 Model 4T0058□ and 4T0072□ Terminals

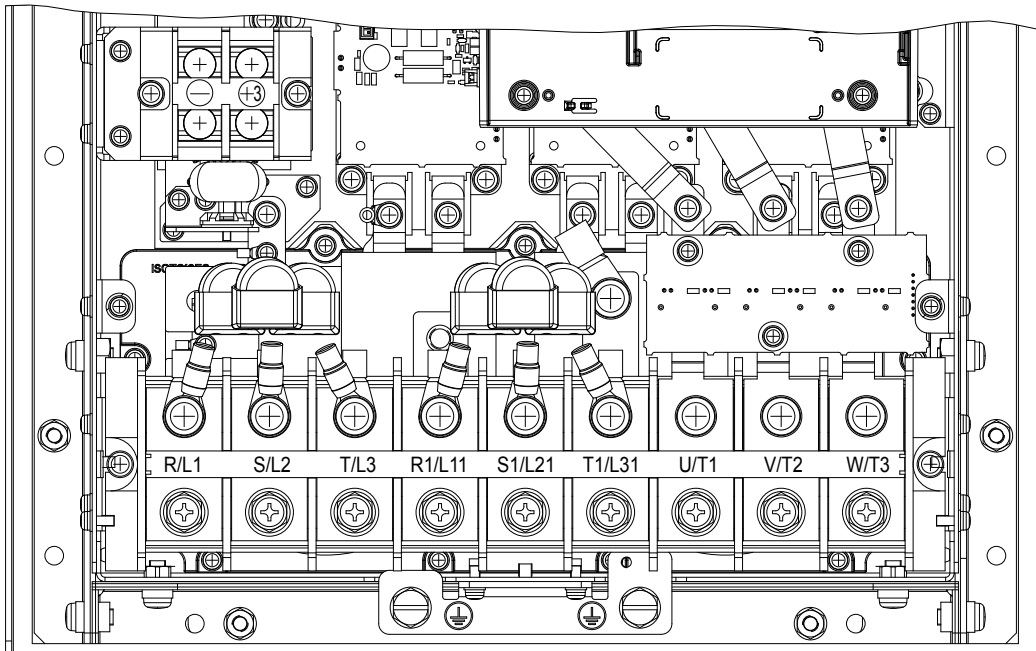

Figure 10 Models 4T0088□ and 4T0103□ Terminals

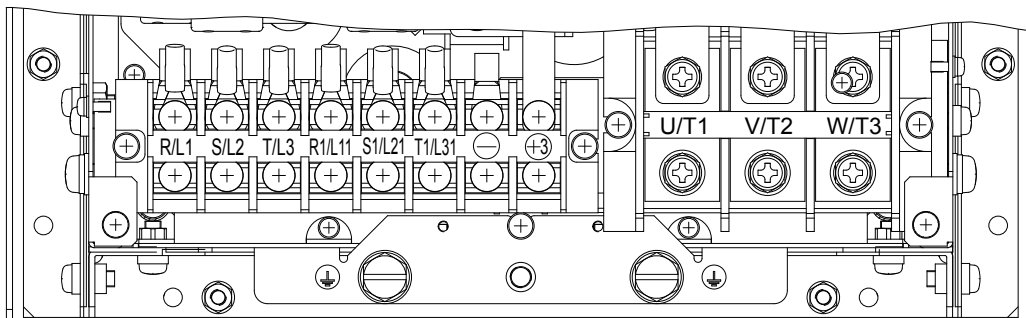

Figure 11 Models 4T0139□ and 4T0165□ Terminals

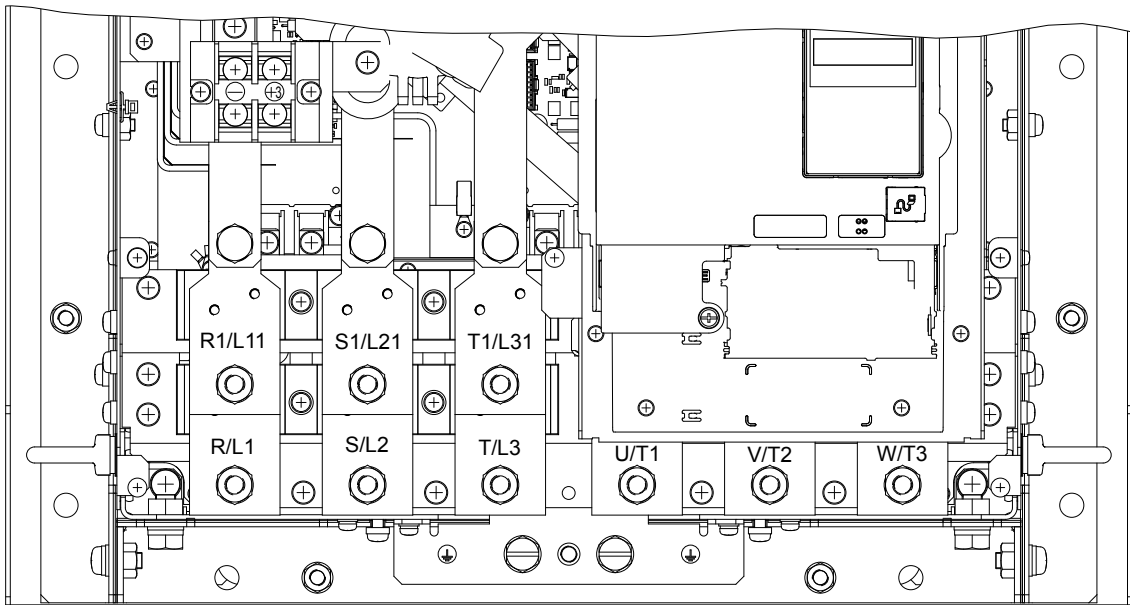

Figure 12 Model 4T0208□ Terminals

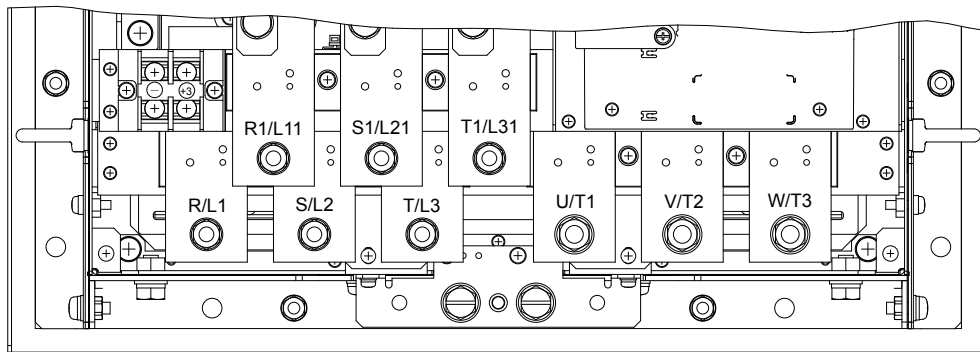

Figure 13 Models 4T0250□ to 4T0362□ Terminals

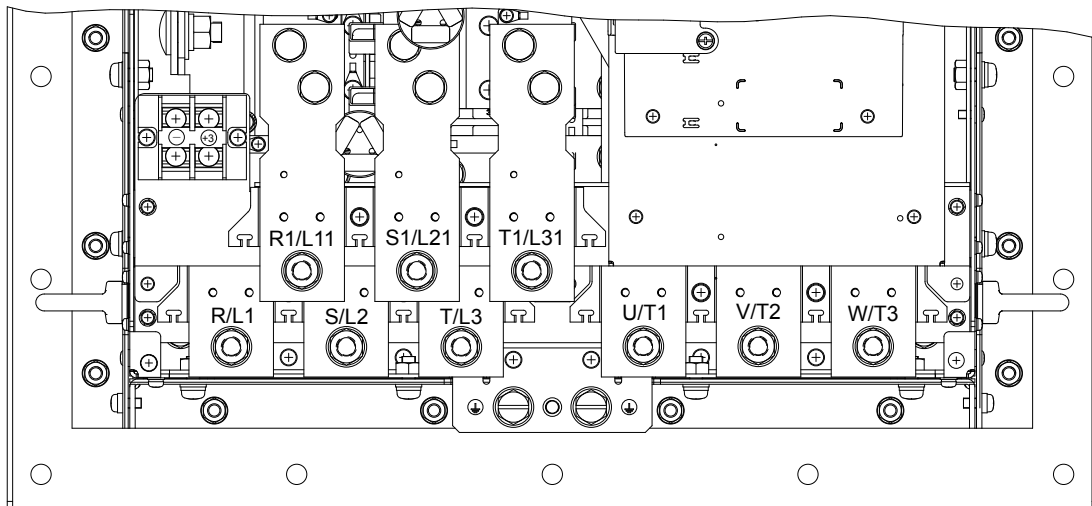

Figure 14 Model 4T0414□ Terminals

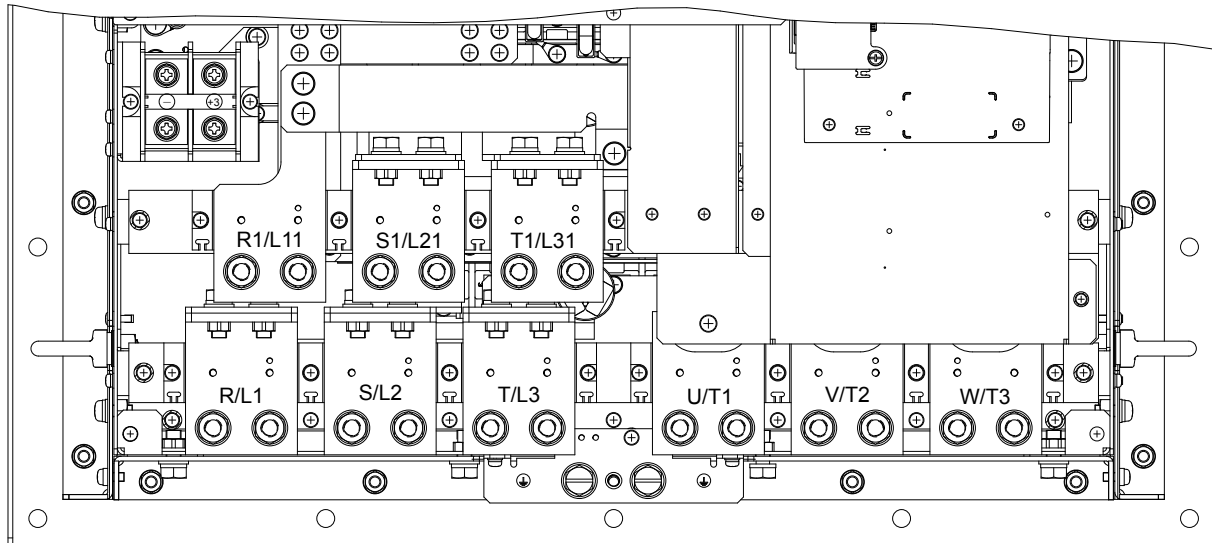

Figure 15 Models 4T0515□ and 4T0675□ Terminals

◆ Main Circuit Wiring

This section describes the functions, specifications, and procedures required to safely and properly wire the main circuit in the drive.

NOTICE: Do not solder the ends of wire connections to the drive. Soldered wiring connections can loosen over time. Improper wiring practices could result in drive malfunction due to loose terminal connections.

NOTICE: Do not switch the drive input to start or stop the motor. Frequently switching the drive on and off shortens the life of the DC bus charge circuit and the DC bus capacitors, and can cause premature drive failures. For the full performance life, refrain from switching the drive on and off more than once every 30 minutes.

■ Main Circuit Terminal Functions

Table 4 Main Circuit Terminal Functions

Terminal	Type		Function
	4T0058□ and 4T0072□	4T0088□ to 4T0675□	
R/L1	Main circuit power supply input Not available		Connects line power to the drive
S/L2			
T/L3			
R1/L11			
S1/L21			
T1/L31			
U/T1	Drive output		Connects to the motor
V/T2			
W/T3			
B1	Braking resistor	Not available	Available for connecting a braking resistor or a braking resistor unit option
B2			
⊖	Not available	Braking unit connection (⊕3 and ⊖)	Only for connecting dynamic braking options
⊕3			
⊕	10 Ω or less		Grounding terminal

Note: Note: DC power supply input is not available for 6-Phase/12-Pulse Input models.

■ Main Circuit Fuses

The 6-Phase/12-Pulse drive requires fuses to be installed on each of the 6 input phases between the 6-Phase/12-Pulse transformer and the drive. Select fuses from [Table 13](#) or [Table 14](#) according to drive model to maintain standards compliance.

◆ Wire Gauges and Tightening Torques

Use the tables in this section to select the appropriate wires and crimp terminals.

Gauges listed in the tables are for use in the United States.

- Note:**
1. Wire gauge recommendations based on drive continuous current ratings (ND) using 75 °C 600 Vac vinyl-sheathed wire assuming ambient temperature within 40 °C and wiring distance shorter than 100 m.
 2. Terminals ⊕3 and ⊖ are for connecting optional power devices. Use caution to connect only approved devices to the correct terminal(s).
- Consider the amount of voltage drop when selecting wire gauges. Increase the wire gauge when the voltage drop is greater than 2% of motor rated voltage. Ensure the wire gauge is suitable for the terminal block. Use the following formula to calculate the amount of voltage drop:

$$\text{Line drop voltage (V)} = \sqrt{3} \times \text{wire resistance } (\Omega/\text{km}) \times \text{wire length (m)} \times \text{current (A)} \times 10^{-3}$$
 - Refer to CDBR manual TOBP C720600 00/TOBP C720600 01 for dynamic braking wire gauges.
 - Use terminals ⊕3 and ⊖ when connecting a CDBR dynamic braking unit.
 - Do not connect a regenerative converter or a regenerative unit to the 6-Phase/12-Pulse drive.
 - *Refer to UL Standards on page 84* for information on UL compliance.

Yaskawa recommends using closed-loop crimp terminals on all drive models. UL/cUL approval requires the use of closed-loop crimp terminals when wiring the drive main circuit terminals. Use only the tools recommended by the terminal manufacturer for crimping. *Refer to Closed-Loop Crimp Terminal Size on page 86* for closed-loop crimp terminal recommendations.

The wire gauges listed in **Table 5** are Yaskawa recommendations and are based on the 6-Phase input current ratings specified in **Table 14**. Refer to local codes for proper wire gauge selections.

Table 5 Wire Gauge and Torque Specifications

Drive Model	Terminal	Wire Range AWG, kcmil	Screw Size	Tightening Torque N·m (lb.in.)
4T0058□	R/L1, S/L2, T/L3	10 to 1/0 (5.3 to 53.5)	M8	9 to 11 (79.7 to 97.4)
	R1/L11, S1/L21, T1/L31			
	U/T1, V/T2, W/T3			
	B1, B2	22 to 10 (0.3 to 5.3)	M4	1.2 (10.6)
	⊕	Refer to applicable codes for wire size	M8	9 to 11 (79.7 to 97.4)
4T0072□	R/L1, S/L2, T/L3	10 to 3/0 (5.3 to 85.0)	M8	9 to 11 (79.7 to 97.4)
	R1/L11, S1/L21, T1/L31			
	U/T1, V/T2, W/T3			
	B1, B2	22 to 10 (0.3 to 5.3)	M4	1.2 (10.6)
	⊕	Refer to applicable codes for wire size	M8	9 to 11 (79.7 to 97.4)
4T0088□ 4T0103□	R/L1, S/L2, T/L3	6 to 250 (13.3 to 127)	M8	9 to 11 (79.7 to 97.4)
	R1/L11, S1/L21, T1/L31			
	U/T1, V/T2, W/T3			
	⊖, ⊕3	22 to 1/0 (0.3 to 53.5)	M6	2.5 to 3.0 (22.1 to 26.6)
	⊕	Refer to applicable codes for wire size	M8	9 to 11 (79.7 to 97.4)
4T0139□ 4T0165□	R/L1, S/L2, T/L3	22 to 1/0 (0.3 to 53.5)	M6	2.5 to 3.0 (22 to 1/0)
	R1/L11, S1/L21, T1/L31			
	⊖, ⊕3			
	U/T1, V/T2, W/T3	6 to 250 (13.3 to 127)	M8	15.0 (132.8)
	⊕	Refer to applicable codes for wire size	M10	18 to 23 (159.3 to 203.6)
4T0208□	R/L1, S/L2, T/L3	Refer to applicable codes for wire size	M10	18 to 23 (159.3 to 203.6)
	R1/L11, S1/L21, T1/L31			
	U/T1, V/T2, W/T3			
	⊖, ⊕3	22 to 1/0 (0.3 to 53.5)	M6	2.5 to 3.0 (22.1 to 26.6)
	⊕	Refer to applicable codes for wire size	M10	18 to 23 (159.3 to 203.6)

3 Electrical Installation

Drive Model	Terminal	Wire Range AWG, kcmil	Screw Size	Tightening Torque N·m (lb.in.)
4T0250□	R/L1, S/L2, T/L3	Refer to applicable codes for wire size	M10	18 to 23 (159.3 to 203.6)
	R1/L11, S1/L21, T1/L31			
	U/T1, V/T2, W/T3			
	⊖, ⊕3	22 to 1/0 (0.3 to 53.5)	M6	2.5 to 3.0 (22.1 to 26.6)
	⊕	Refer to applicable codes for wire size	M10	18 to 23 (159.3 to 203.6)
4T0296□	R/L1, S/L2, T/L3	Refer to applicable codes for wire size	M10	18 to 23 (159.3 to 203.6)
	R1/L11, S1/L21, T1/L31		M12	32 to 40 (283.2 to 354.0)
	U/T1, V/T2, W/3			2.5 to 3.0 (22.1 to 26.6)
	⊖, ⊕3	22 to 1/0 (0.3 to 53.5)	M6	2.5 to 3.0 (22.1 to 26.6)
	⊕	Refer to applicable codes for wire size	M12	32 to 40 (283.2 to 354.0)
4T0362□	R/L1, S/L2, T/L3	Refer to applicable codes for wire size	M10	18 to 23 (159.3 to 203.6)
	R1/L11, S1/L21, T1/L31		M12	32 to 40 (283.2 to 354.0)
	U/T1, V/T2, W/T3			2.5 to 3.0 (22.1 to 26.6)
	⊖, ⊕3	22 to 1/0 (0.3 to 53.5)	M6	2.5 to 3.0 (22.1 to 26.6)
	⊕	Refer to applicable codes for wire size	M12	32 to 40 (283.2 to 354.0)
4T0414□	R/L1, S/L2, T/L3	Refer to applicable codes for wire size	M12	32 to 40 (283.2 to 354.0)
	R1/L11, S1/L21, T1/L31			
	U/T1, V/T2, W/T3			
	⊖, ⊕3	22 to 1/0 (0.3 to 53.5)	M6	2.5 to 3.0 (22.1 to 26.6)
	⊕	Refer to applicable codes for wire size	M12	32 to 40 (283.2 to 354.0)
4T0515□	R/L1, S/L2, T/L3	Refer to applicable codes for wire size	M12	32 to 40 (283.2 to 354.0)
	R1/L11, S1/L21, T1/L31			
	U/T1, V/T2, W/T3			
	⊖, ⊕3	13.3 to 127 (6 to 250)	M8	13.5 to 15 (119.5 to 132.8)
	⊕	Refer to applicable codes for wire size	M12	32 to 40 (283.2 to 354.0)
4T0675□	R/L1, S/L2, T/L3	Refer to applicable codes for wire size	M12	32 to 40 (283.2 to 354.0)
	R1/L11, S1/L21, T1/L31			
	U/T1, V/T2, W/T3			
	⊖, ⊕3	13.3 to 127 (6 to 250)	M8	13.5 to 15 (119.5 to 132.8)
	⊕	Refer to applicable codes for wire size	M12	32 to 40 (283.2 to 354.0)

◆ Wiring Checklist

<input checked="" type="checkbox"/>	No.	Item	Page(s)
Drive, Peripherals, Option Cards			
<input type="checkbox"/>	1	Check drive model number to ensure receipt of correct model.	10
<input type="checkbox"/>	2	Make sure you have the correct braking resistors, DC link chokes, noise filters, and other peripheral devices.	
<input type="checkbox"/>	3	Check the option card model number.	
Installation Area and Physical Setup			
<input type="checkbox"/>	4	Ensure that the area surrounding the drive complies with specifications.	13
Power Supply Voltage, Output Voltage			

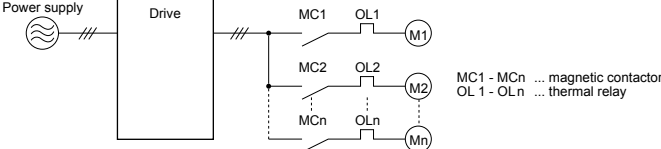
<input checked="" type="checkbox"/>	No.	Item	Page(s)
<input type="checkbox"/>	5	The voltage from the power supply should be within the input voltage specification range of the drive.	–
<input type="checkbox"/>	6	The voltage rating for the motor should match the drive output specifications.	10
<input type="checkbox"/>	7	Verify that the drive is properly sized to run the motor.	
Main Circuit Wiring			
<input type="checkbox"/>	8	Confirm proper branch circuit protection as specified by national and local codes.	15
<input type="checkbox"/>	9	Properly wire the power supply to drive terminals R/L1, S/L2, T/L3, R1/L11, S1/L21, and T1/L31. Note: Confirm that a 6-Phase/12-Pulse isolation transformer with each of the output windings phase-shifted by 30 electrical degrees or a Hybrid 6-Phase topology is installed on the power supply.	18
<input type="checkbox"/>	10	Properly wire the drive and motor together. The motor lines and drive output terminals U/T1, V/T2, and W/T3 should match in order to produce the desired phase order. If the phase order is incorrect, the drive will rotate in the opposite direction.	–
<input type="checkbox"/>	11	Use 600 Vac vinyl-sheathed wire for the power supply and motor lines.	23
<input type="checkbox"/>	12	Use the correct wire gauges for the main circuit. <ul style="list-style-type: none"> Consider the amount of voltage drop when selecting wire gauges. Increase the wire gauge when the voltage drop is greater than 2% of motor rated voltage. Ensure the wire gauge is suitable for the terminal block. Use the following formula to calculate the amount of voltage drop: $\text{Line drop voltage (V)} = \sqrt{3} \times \text{wire resistance } (\Omega/\text{km}) \times \text{wire length (m)} \times \text{current (A)} \times 10^{-3}$ If the cable between the drive and motor exceeds 50 m, adjust the carrier frequency set to C6-02 accordingly. 	23
<input type="checkbox"/>	13	Properly ground the drive.	–
<input type="checkbox"/>	14	Tighten control circuit and grounding terminal screws.	23
<input type="checkbox"/>	15	Set up overload protection circuits when running multiple motors from a single drive.  <p>Note: Close MC1 – MCn before operating the drive. MC1 – MCn cannot be switched off during run.</p>	–
<input type="checkbox"/>	16	Install a magnetic contactor when using a dynamic braking option. Properly install the resistor and ensure that overload protection shuts off the power supply using the magnetic contactor.	–
<input type="checkbox"/>	17	Verify phase advancing capacitors, input noise filters, or GFCIs are NOT installed on the output side of the drive.	–
Control Circuit Wiring			
<input type="checkbox"/>	18	Use twisted-pair line for all drive control circuit wiring.	–
<input type="checkbox"/>	19	Ground the shields of shielded wiring to the GND ⊕ terminal.	–
<input type="checkbox"/>	20	For 3-Wire sequence, set parameters for multi-function contact input terminals S1 – S8, and wire control circuits.	–
<input type="checkbox"/>	21	Properly wire any option cards.	–
<input type="checkbox"/>	22	Check for any other wiring mistakes. Only use a multimeter to check wiring.	–
<input type="checkbox"/>	23	Properly fasten drive control circuit terminal screws.	23
<input type="checkbox"/>	24	Pick up all wire clippings.	–
<input type="checkbox"/>	25	Ensure that no frayed wires on the terminal block are touching other terminals or connections.	–
<input type="checkbox"/>	26	Properly separate control circuit wiring and main circuit wiring.	–
<input type="checkbox"/>	27	Analog signal line wiring should not exceed 50 m.	–
<input type="checkbox"/>	28	Safe Disable input wiring should not exceed 30 m.	–

4 Start-Up Programming & Operation

◆ Powering Up the Drive

Review the following checklist before applying power.

Item to Check	Description
Power supply	6-Phase/12-Pulse Isolated 380 to 480 Vac 50/60 Hz, 30 electrical degrees phase-shifted each phase
	Properly wire the power supply input terminals (R/L1, S/L2, T/L3, R1/L11, S1/L21, T1/L31). <1>
	Check for proper grounding of drive and motor.
Drive output terminals and motor terminals	Properly wire drive output terminals U/T1, V/T2, and W/T3 with motor terminals U, V, and W.
Control circuit terminals	Check control circuit terminal connections.
Drive control terminal status	Open all control circuit terminals (off).
Status of the load and connected machinery	Decouple the motor from the load.

<1> Install a 6-Phase/12-Pulse isolation transformer with each of the output windings phase-shifted by 30 electrical degrees or use a Hybrid 6-Phase topology.

5 Troubleshooting

NOTICE

Refer to the A1000 Technical Manual SIEP C710616 41 for information on *Troubleshooting* and complete product instructions necessary for proper installation, set-up, troubleshooting and maintenance.
The A1000 Technical Manual is posted on the Yaskawa website, www.yaskawa.com.

WARNING

Electrical Shock Hazard

Do not connect or disconnect wiring while the power is on.

Failure to comply could result in death or serious injury.

Before servicing, disconnect all power to the equipment. The internal capacitor remains charged even after the power supply is turned off. The charge indicator LED will extinguish when the DC bus voltage is below 50 Vdc. To prevent electric shock, wait for at least the time specified on the warning label; after all indicators are OFF, measure for unsafe voltages to confirm the drive is safe prior to servicing.

Do not operate equipment with covers removed.

Failure to comply could result in death or serious injury.

The diagrams in this section may illustrate drives without covers or safety shields to display details. Be sure to reinstall covers or shields before operating the drives and run the drives according to the instructions described in this manual.

Do not touch terminals before the capacitors have fully discharged.

Failure to comply could result in death or serious injury.

Before servicing, disconnect all power to the equipment. The internal capacitor remains charged even after the power supply is turned off. The charge indicator LED will extinguish when the DC bus voltage is below 50 Vdc. To prevent electric shock, wait for at least the time specified on the warning label; after all indicators are OFF, measure for unsafe voltages to confirm the drive is safe prior to servicing.

After blowing a fuse or tripping a GFCI, do not attempt to restart the drive or operate peripheral devices until five minutes pass and CHARGE lamp is OFF.

Failure to comply could result in death, serious injury, and damage to the drive.

Check wiring and peripheral device ratings to identify the cause of trips.

Contact your supplier if the cause cannot be identified.

Installation, maintenance, inspection and servicing must be performed only by authorized personnel familiar with installation, adjustment and maintenance of AC drives.

Do not perform work on the drive while wearing loose clothing, jewelry, or without eye protection.

Failure to comply could result in death or serious injury.

Do not remove covers or touch circuit boards while the power is on.

Failure to comply could result in death or serious injury.

◆ Fault Reset Methods

When a fault occurs, the cause of the fault must be removed and the drive must be restarted. The table below lists the different ways to restart the drive.

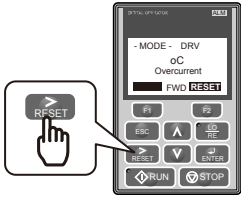
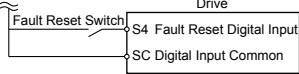
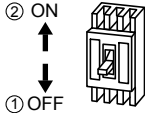
After the Fault Occurs	Procedure	
Fix the cause of the fault, restart the drive, and reset the fault	Press  on the digital operator when the error code is displayed.	
Resetting via Fault Reset Digital Input S4	Close then open the fault signal digital input via terminal S4. S4 is set for "Fault Reset" as default (H1-04 = 14).	
Turn off the main power supply if the above methods do not reset the fault. Reapply power after the digital operator display has turned off.		

Note: If the Run command is present, the drive will disregard any attempts to reset the fault. Remove the Run command before attempting to clear a fault situation.

6 Drive Options and Peripheral Devices

Table 6 lists the names of the various peripheral devices, accessories, and options available for Yaskawa drives. Contact Yaskawa or your Yaskawa agent to order these peripheral devices.

- **Peripheral Device Selection:** Refer to the Yaskawa catalog for selection and part numbers.
- **Peripheral Device Installation:** Refer to the corresponding option manual for installation instructions.

Table 6 Available Peripheral Devices

Option	Model Number	Description
Power Options		
AC Reactor	–	Protects the drive when operating from a large power supply and improves the power factor by suppressing harmonic distortion. Highly recommended for power supplies that exceed 600 kVA.
Braking Resistor	–	For use with systems that require dynamic braking with up to 3% ED. If higher ED is required, use a Braking Resistor Unit.
Input/Output Option Cards		
Analog Input	AI-A3	<ul style="list-style-type: none"> • Allows high precision, high resolution analog reference input • Input channels: 3 • Voltage input: -10 to 10 Vdc (20 kΩ), 13-bit signed • Current input: 4 to 20 mA or 0 to 20 mA (250 Ω), 12-bit
Analog Monitor	AO-A3	<ul style="list-style-type: none"> • Provides extra multi-function analog output terminals • Output channels: 2 • Output voltage: -10 to 10 V, 11-bit (signed)
Digital Input	DI-A3	<ul style="list-style-type: none"> • Sets the frequency reference by digital inputs • Input channels: 18 (including SET signal and SIGN signal) • Input signal type: BCD 16-bit (4-digit), 12-bit (3-digit), 8-bit (2-digit) • Input signal: 24 Vdc, 8 mA
Digital Output	DO-A3	<ul style="list-style-type: none"> • Provides extra insulated multi-function digital outputs • Photocoupler relays: 6 (48 V, up to 50 mA) • Contact relays: 2 (250 Vac/up to 1 A, 30 Vdc/up to 1 A)
Motor Speed Feedback Option Cards		
Motor PG Feedback Line Driver Interface	PG-X3	<ul style="list-style-type: none"> • For speed feedback input by connecting a motor encoder • Input: 3-track (can be used with 1 or 2 tracks), line driver, 300 kHz max • Pulse monitor: Matches RS-422 level • Output: 3-track, line driver • Encoder power supply: 5 V or 12 V, max current 200 mA
Motor PG Feedback Open Collector Interface	PG-B3	<ul style="list-style-type: none"> • For speed feedback input by connecting a motor encoder • Input: 3-track (can be used with 1 or 2 tracks), HTL encoder connection, 50 kHz max • Output: 3-track, open collector • Encoder power supply: 12 V, max current 200 mA
EnDat Encoder	PG-F3	<ul style="list-style-type: none"> • For speed feedback input by connecting a motor encoder • Encoder type: EnDat 2.1/01, EnDat 2.2/01, and EnDat 2.2/ 22 (HEIDENHAIN), HIPERFACE (SICK-STEGMANN) • Maximum input frequency: 20 kHz • Pulse monitor: Matches RS-422 level • Output voltage: 5 V\pm5%, 8 V\pm10% • Maximum output current: 200 mA • Encoder power supply: 5 V, max current 330 mA or 8 V, max current 150 mA • Wiring length: 20 m max. for the encoder, 30 m max. for the pulse monitor Note: <ol style="list-style-type: none"> 1. Available in drive software versions PRG: 1018 and later. 2. The PG-F3 option can only be used in CLV/PM.
Motor Feedback Resolver Interface	PG-RT3	<ul style="list-style-type: none"> • For motor speed feedback by connecting a resolver that meets the specifications set by Yaskawa. • Input voltage: 10 Vac rms 10 kHz • Transformation ratio: 0.5 \pm 5% • Maximum input current: 100 mA rms Note: Available in drive software versions PRG: 1017 and later.

6 Drive Options and Peripheral Devices

Option	Model Number	Description
Communication Option Cards		
EtherNet/IP	SI-EN3	Connects to an EtherNet/IP network.
Modbus TCP/IP	SI-EM3	Connects to a Modbus TCP/IP network.
PROFINET	SI-EP3	Connects to a PROFINET network.
LonWorks	SI-W3	Connects to a LonWorks network.
DeviceNet	SI-N3	Connects to a DeviceNet network.
PROFIBUS-DP	SI-P3	Connects to a PROFIBUS-DP network.
MECHATROLINK-II	SI-T3	Connects to a MECHATROLINK-II network.
MECHATROLINK-III	SI-ET3	Connects to a MECHATROLINK-III network.
BACnet	SI-B3	Connects to a BACnet network.
EtherCAT	SI-ES3	Connects to an EtherCAT network.
CC-Link <1>	SI-C3	Connects to a CC-Link network.
CANopen <1>	SI-S3	Connects to a CANopen network.
Interface Options		
LCD Operator	JVOP-180	Digital operator with 8 languages, clear text LCD display, and copy function; max. cable length for remote usage: 3 m
LED Operator	JVOP-182	5-digit LED operator; max. cable length for remote usage: 3 m
Remote Operator Cable	UWR000051, 1 m cable UWR000052, 2 m cable	RJ-45, 8-pin straight through, UTP CAT5e, extension cable (1 m or 2 m) to connect the digital operator for remote operation.
USB Copy Unit	JVOP-181	<ul style="list-style-type: none"> Allows the user to copy and verify parameter settings between drives. Functions as an adapter to connect the drive to a USB port on a PC.
Mechanical Options		
IP20/NEMA Type 1 Kit	EZZ021136A-H	Parts to make the drive conform to IP20/NEMA Type 1 enclosure requirements.
IP20/NEMA Type 1, 4, 12 Blank Keypad Kit	UUX0000526	Provides digital operator functionality on an enclosure designed for IP20/NEMA Type 1, 3R, 4, 4X, 12, or IP□6 environment. This keypad has a blank label on the front.
IP20/NEMA Type 1, 4, 12 Yaskawa Logo Keypad Kit	UUX0000527	Provides digital operator functionality on an enclosure designed for IP20/NEMA Type 1, 3R, 4, 4X, 12, or IP□6 environment. This keypad has a Yaskawa brand label on the front.
Others		
24 V Power Supply	PS-A10HB	Supplies the drive controller with 24 Vdc power during main power loss.
PC Software Tools		
DriveWizard Industrial	Contact Yaskawa	PC tool for drive setup and parameter management
DriveWorksEZ	Contact Yaskawa	PC tool for enhanced programming of the drive

<1> Limited support. Contact a Yaskawa representative or the nearest Yaskawa sales office for assistance.

◆ Connecting Peripheral Devices

Figure 16 illustrates how to configure the drive and motor to operate with various peripheral devices. Refer to the specific manual for the devices shown below for more detailed installation instructions.

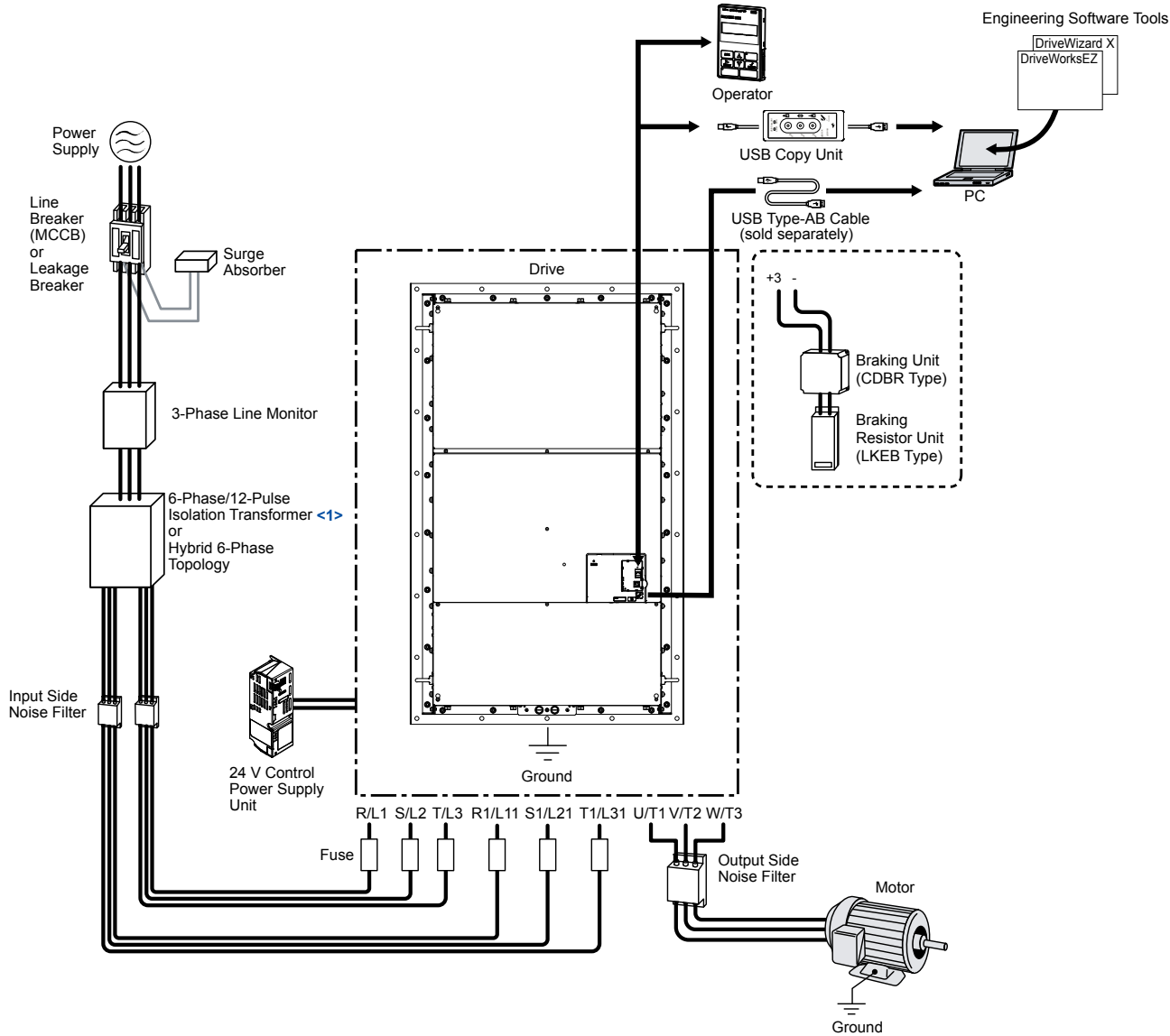

Figure 16 Connecting Peripheral Devices

<1> With each of the output windings phase-shifted by 30 electrical degrees.

Note: If the drive is set to trigger a fault output when the fault restart function is activated (L5-02 = 1), then a sequence to interrupt power when a fault occurs will turn off the power to the drive while the drive attempts to restart. The default setting for L5-02 is 0 (fault output active during restart).

◆ Installing Peripheral Devices

This section describes the proper steps and precautions to take when installing or connecting various peripheral devices to the drive.

NOTICE: Use a class 2 power supply when connecting to the control terminals. Improper application of peripheral devices could result in drive performance degradation due to improper power supply. Refer to NEC Article 725 Class 1, Class 2, and Class 3 Remote-Control, Signaling, and Power Limited Circuits for requirements concerning class 2 power supplies.

■ Dynamic Braking Options

Dynamic braking (DB) helps bring the motor to a smooth and rapid stop when working with high inertia loads. As the drive lowers the frequency of a motor moving a high inertia load, regeneration occurs. This can cause an overvoltage situation when the regenerative energy flows back into the DC bus capacitors. A braking resistor prevents these overvoltage faults.

Refer to CDBR manual TOBP C720600 00 or TOBP C720600 01 when connecting a dynamic braking option to the drive.

NOTICE: Do not allow unqualified personnel to use the product. Failure to comply could result in damage to the drive or braking circuit. Carefully review CDBR manual TOBP C720600 00 or TOBP C720600 01 when connecting a dynamic braking option to the drive.

- Note:**
1. Properly size the braking circuit to dissipate the power required to decelerate the load in the desired time. Ensure that the braking circuit can dissipate the energy for the set deceleration time prior to running the drive.
 2. Set L8-55 to 0 to disable the internal braking transistor of the drive protection when using braking resistor options.

WARNING! Fire Hazard. The dynamic braking resistor connection terminals are B1 and B2 on models 4T0058□ and 4T0072□. Do not connect a dynamic braking resistor directly to any other terminals. Improper wiring connections could result in death or serious injury by fire. Failure to comply may result in damage to the braking circuit or drive.

WARNING! Fire Hazard. The CDBR dynamic braking unit connection terminals are ⊖ and ⊕3 on models 4T0088□ to 4T0675□. Do not connect a CDBR dynamic braking unit directly to any other terminals. Improper wiring connections could result in death or serious injury by fire. Failure to comply may result in damage to the braking circuit or drive.

NOTICE: Connect dynamic braking to the drive as shown in the I/O wiring examples. Improperly wiring braking circuits could result in damage to the drive or equipment.

Installing a Dynamic Braking Resistor

Dynamic braking resistors connect to drive terminals B1 and B2 on models 4T0058□ and 4T0072□ as shown in [Figure 17](#). Utilize the thermal overload contact to switch off the drive in the event of braking resistor overheating.

The internal braking resistor overload protection of the drive cannot protect dynamic braking resistors. Set L8-01 to 0 to disable this function.

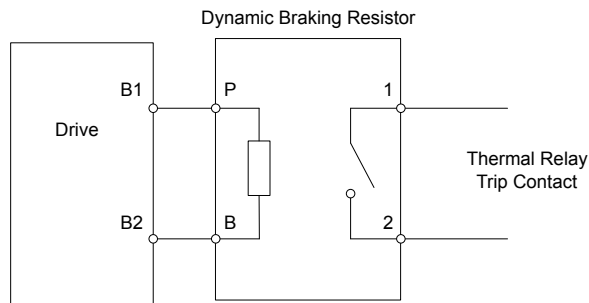

Figure 17 Connecting a Dynamic Braking Resistor

Installing Other Types of Dynamic Braking Resistors

When installing non-Yaskawa dynamic braking resistors, make sure that the braking transistor in the braking unit will not be overloaded with the required duty cycle and the selected resistance value. Use a resistor that is equipped with a thermal overload relay contact, and utilize this contact to disconnect main power to the drive in case of braking resistor overheating.

Dynamic Braking Resistor Overload Protection

When using a dynamic braking resistor option, interrupt the power supply using a sequence such as the one shown in [Figure 18](#) for protection in the event of braking resistor overload.

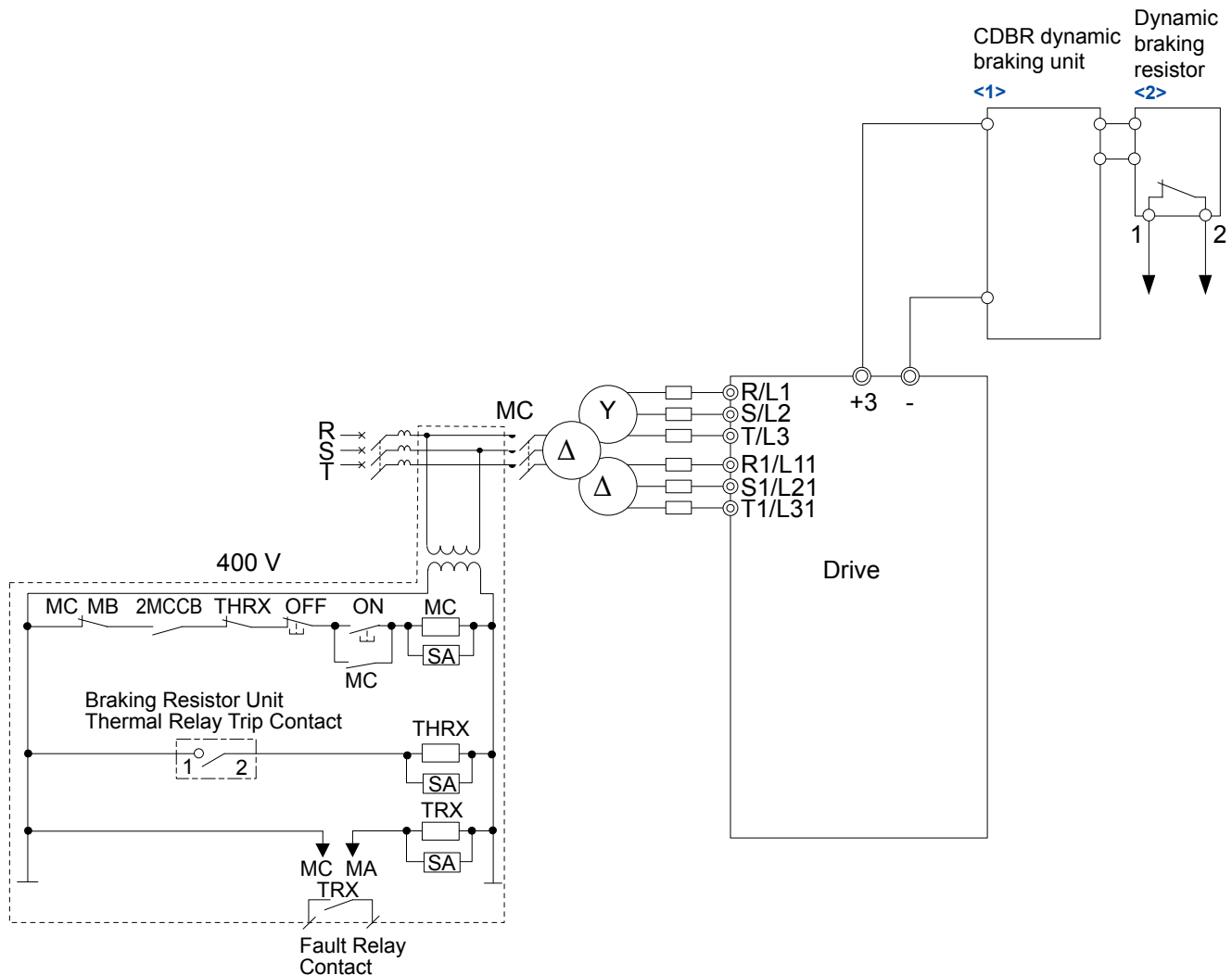

Figure 18 Power Supply Interrupt for Dynamic Braking Resistor Overheat Protection

<1> A CDBR dynamic braking unit cannot be connected to models 4T0058□ or 4T0072□.

<2> A dynamic braking resistor can be connected to the B1 and B2 terminals on models 4T0058□ and 4T0072□.

Installing a CDBR Dynamic Braking Unit

Connect the ⊕3 terminal from the drive to the positive terminal on the CDBR dynamic braking unit and wire together the negative terminals on the drive and CDBR dynamic braking unit.

Connect the dynamic braking resistor to CDBR dynamic braking unit terminals ⊕0 and ⊖0. Refer to [Figure 18](#) and [Figure 19](#) for proper configuration.

Wire the thermal overload relay normally open contacts of the CDBR dynamic braking unit and the dynamic braking resistor in parallel, and connect this signal to a control circuit as shown in [Figure 18](#) to interrupt the main input power supply to the drive in the event of an overload.

Set L8-55 to 0 to disable dynamic braking transistor protection.

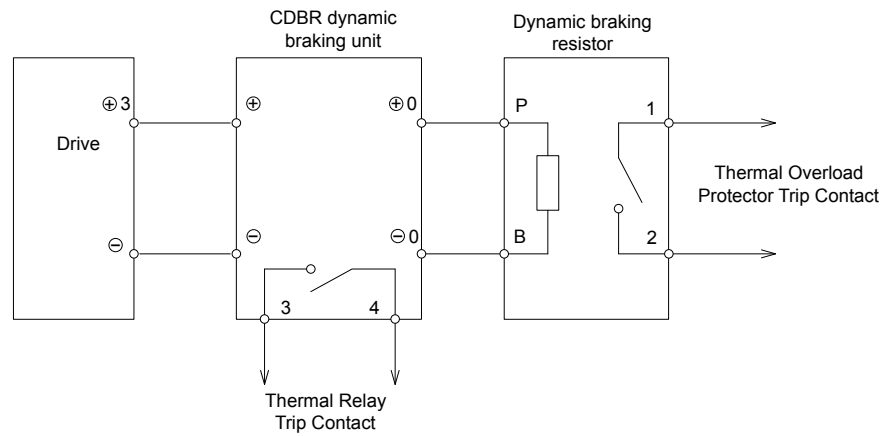

Figure 19 Connecting a CDBR Dynamic Braking Unit and Dynamic Braking Resistor on Models 4T0088□ to 4T0675□

Note: To install a CDBR dynamic braking unit to models 4T0058□ and 4T0072□ with built-in dynamic braking transistors, first connect terminal B1 to the positive terminal on the CDBR dynamic braking unit, then wire the negative terminals on the drive and braking unit together. Terminal B2 is not used.

7 Periodic Inspection & Maintenance

◆ Drive Cooling Fans

Contact a Yaskawa representative or the nearest Yaskawa sales office to order replacement cooling fans as required.

For drives with multiple cooling fans, replace all the fans when performing maintenance to ensure maximum product performance life.

■ Number of Cooling Fans

Drive Model	Cooling Fans	Circulation Fans	Control Board Cooling Fans
4T0058□	2	–	–
4T0072□	2	–	–
4T0088□	2	–	–
4T0103□	2	–	–
4T0139□	2	–	–
4T0165□	2	–	–
4T0208□	2	–	–
4T0250□	3	–	–
4T0296□	3	–	–
4T0362□	3	1	–
4T0414□	3	1	–
4T0515□	3	2	2
4T0675□	3	2	2

■ Cooling Fan Replacement

NOTICE

Refer to the A1000 Technical Manual SIEP C710616 41 for information on *Cooling Fan Replacement* and complete product instructions necessary for proper maintenance.

The A1000 Technical Manual is posted on the Yaskawa website, www.yaskawa.com.

■ Cooling Fan Component Names

WARNING! Electrical Shock Hazard. Do not connect or disconnect wiring while the power is on. Failure to comply can result in serious personal injury. Before servicing the drive, disconnect all power to the equipment. The internal capacitor remains charged even after the power supply is turned off. After shutting off the power, wait for at least the amount of time specified on the drive before touching any components.

CAUTION! Burn Hazard. Do not touch a hot drive heatsink. Failure to comply could result in minor or moderate injury. Shut off the power to the drive when replacing the cooling fan. To prevent burns, wait at least 15 minutes and ensure the heatsink has cooled down.

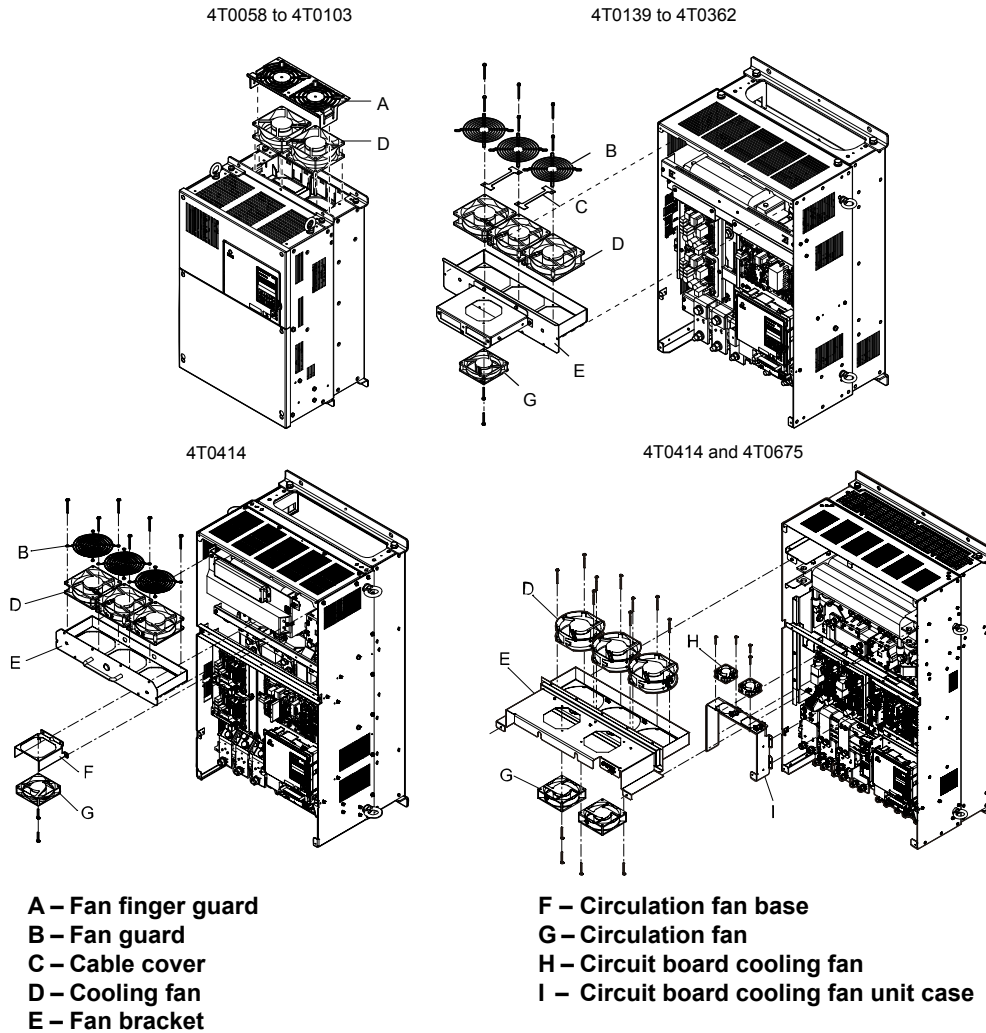

Figure 20 Cooling Fan Component Names

◆ Gasket Replacement for Flange Type Enclosures

■ Gasket Replacement Procedure

1. Use a plastic scraper to remove the damaged or torn gasket without scratching the mounting surfaces.
2. Peel off the adhesive cover from the replacement gasket.
3. Align the holes on the mounting flange or fan bracket with the holes on the replacement gasket and apply the new gasket.

■ Gasket Replacement Parts

Each replacement part contains two gaskets in the event that a gasket is torn during application.

Contact a Yaskawa representative or the nearest Yaskawa sales office to order replacement gaskets as required.

Table 7 Gasket Replacement Part Numbers

Drive Model	Replacement Part	Part Number
4T0058U	Mounting Flange Gasket	UGK00418-A
4T0072U	Mounting Flange Gasket	UGK00419-A
4T0088U 4T0103U	Mounting Flange Gasket	UGK00420-A
4T0139U 4T0165U	Fan Bracket Gasket	UGK00421-A
4T0208U	Fan Bracket Gasket	UGK00422-A
4T0250U 4T0296U 4T0362U	Fan Bracket Gasket	UGK00423-A
4T0414U	Fan Bracket Gasket	UGK00424-A
4T0515U 4T0675U	Fan Bracket Gasket	UGK00425-A

8 Specifications

◆ Power Ratings for Models 4T0058□ to 4T0208□

Table 8 Power Ratings for Models 4T0058□ to 4T0208□

Item		Specification							
Drive Model		4T0058□	4T0072□	4T0088□	4T0103□	4T0139□	4T0165□	4T0208□	
Maximum Applicable Motor Capacity kW (HP) <1>	ND Rating	30 (40)	37 (50)	45 (60)	55 (75)	75 (100)	90 (125)	110 (150)	
	HD Rating	22 (25-30)	30 (40)	37 (50-60)	45 (50-60)	55 (75)	75 (100)	90 (125-150)	
Input Current (A) <2>	ND Rating	54	66	79	97	131	156	190	
	HD Rating	40	54	66	79	97	131	156	
Input	Rated Voltage Rated Frequency	6-Phase/12-Pulse: 380 Vac to 480 Vac 50/60 Hz Note: 6-Phase isolated supply with each of the output windings phase-shifted by 30 electrical degrees or Hybrid 6-phase topology.							
	Allowable Voltage Fluctuation	-15 to 10%							
	Allowable Frequency Fluctuation	±5%							
	Input Power (kVA)	ND Rating	53.0	64.9	78.6	96.0	130	156	189
	HD Rating	39.3	53.0	64.9	78.6	96.0	130	155	
Output	Rated Output Capacity (kVA) <3>	ND Rating <4>	44	55	67	78	106	126	159
		HD Rating	34	48	57	69	85	114	137 <6>
	Rated Output Current (A)	ND Rating <4>	58	72	88	103	139	165	208
		HD Rating	45 <5>	60 <5>	75 <5>	91 <5>	112 <5>	150 <6>	180 <6>
	Overload Tolerance	ND Rating: 120% of rated output current for 60 s HD Rating: 150% of rated output current for 60 s (Derating may be required for applications that start and stop frequently)							
	Carrier Frequency	User adjustable between 1 and 15 kHz				User adjustable between 1 and 10 kHz			
	Maximum Output Voltage (V)	Three-phase: 380 to 480 Vac (proportional to input voltage)							
	Maximum Output Frequency (Hz)	400 Hz (user-adjustable)							

- <1> The motor capacity (HP) refers to a NEC rated 4-pole motor. The rated output current of the drive output amps should be equal to or greater than the motor current. Select the appropriate capacity drive if operating the motor continuously above motor nameplate current.
- <2> Assumes operation at the rated output current. Input current rating varies depending on the power supply transformer, input reactor, wiring conditions, and power supply impedance. This input current rating is the 3-Phase total input current rating. *Refer to Alternative AC Drive Branch Circuit Protection on page 85* for the 6-Phase input current rating.
- <3> Rated motor capacity is calculated with a rated output voltage of 440 V.
- <4> Carrier frequency is set to 2 kHz. Current derating is required in order to raise the carrier frequency.
- <5> Carrier frequency can be increased to 8 kHz while keeping this current derating. Higher carrier frequency settings require derating.
- <6> Carrier frequency can be increased to 5 kHz while keeping this current derating. Higher carrier frequency settings require derating.

◆ Power Ratings for Models 4T0250□ to 4T0675□

Table 9 Power Ratings for Models 4T0250□ to 4T0675□

Item		Specification						
Drive Model		4T0250□	4T0296□	4T0362□	4T0414□	4T0515□	4T0675□	
Maximum Applicable Motor Capacity kW (HP) <1>	ND Rating	132 (200)	160 (250)	185 (300)	220 (350)	250 (400)	355 (500-550)	
	HD Rating	110 (150)	132 (200)	160 (250)	185 (300)	220 (350)	315 (400-450-500)	
Input Current (A) <2>	ND Rating	228	275	317	376	427	603	
	HD Rating	190	228	275	317	376	511	
Input	Rated Voltage Rated Frequency	6-Phase/12-Pulse: 380 Vac to 480 Vac 50/60 Hz Note: 6-Phase isolated supply with each of the output windings phase-shifted by 30 electrical degrees or Hybrid 6-phase topology.						
	Allowable Voltage Fluctuation	-15 to 10%						
	Allowable Frequency Fluctuation	±5%						
	Input Power (kVA)	ND Rating	227	274	316	375	425	601
	HD Rating	189	227	275	316	375	534	
Output	Rated Output Capacity (kVA) <3>	ND Rating	191	226	276	316	392	514
		HD Rating	165 <5>	198 <5>	232 <5>	282 <4>	343 <4>	461 <4>
	Rated Output Current (A)	ND Rating	250	296	362	414	515	675
		HD Rating	216 <5>	260 <5>	304 <5>	370 <4>	450 <4>	605 <4>
	Overload Tolerance	ND Rating: 120% of rated output current for 60 s HD Rating: 150% of rated output current for 60 s (Derating may be required for applications that start and stop frequently)						
	Carrier Frequency	User adjustable between 1 and 10 kHz			User adjustable between 1 and 5 kHz			
	Maximum Output Voltage (V)	Three-phase: 380 to 480 Vac (proportional to input voltage)						
	Maximum Output Frequency (Hz)	400 Hz (user-adjustable)						

- <1> The motor capacity (HP) refers to a NEC rated 4-pole motor. The rated output current of the drive output amps should be equal to or greater than the motor current. Select the appropriate capacity drive if operating the motor continuously above motor nameplate current.
- <2> Assumes operation at the rated output current. Input current rating varies depending on the power supply transformer, input reactor, wiring conditions, and power supply impedance. This input current rating is the 3-Phase total input current rating. *Refer to Alternative AC Drive Branch Circuit Protection on page 85* for the 6-Phase input current rating.
- <3> Rated motor capacity is calculated with a rated output voltage of 440 V.
- <4> Carrier frequency is set to 2 kHz. Current derating is required in order to raise the carrier frequency.
- <5> Carrier frequency can be increased to 5 kHz while keeping this current derating. Higher carrier frequency settings require derating.

◆ Drive Specifications

- Note:**
1. Perform rotational Auto-Tuning to obtain the performance specifications given below.
 2. For optimum performance life of the drive, install the drive in an environment that meets the required specifications.

Item	Specification
Control Method	The following control methods can be set using drive parameters: <ul style="list-style-type: none"> • V/f Control (V/f) • V/f Control with PG (V/f w/PG) • Open Loop Vector Control (OLV) • Closed Loop Vector Control (CLV) • Open Loop Vector Control for PM (OLV/PM) • Advanced Open Loop Vector Control for PM (AOLV/PM) • Closed Loop Vector Control for PM (CLV/PM)
Frequency Control Range	0.01 to 400 Hz
Frequency Accuracy (Temperature Fluctuation)	Digital input: within $\pm 0.01\%$ of the max output frequency (-10 to $+40$ °C) Analog input: within $\pm 0.1\%$ of the max output frequency (25 °C ± 10 °C)
Frequency Setting Resolution	Digital inputs: 0.01 Hz Analog inputs: 1/2048 of the maximum output frequency setting (11 bit plus sign)
Output Frequency Resolution	0.001 Hz
Frequency Setting Signal	Main speed frequency reference: DC -10 to $+10$ V (20 k Ω), DC 0 to $+10$ V (20 k Ω), 4 to 20 mA (250 Ω), 0 to 20 mA (250 Ω) Main speed reference: Pulse train input (max. 32 kHz)
Starting Torque $\leftarrow \rightarrow$	V/f, V/f w/PG: 150% at 3 Hz OLV: 200% at 0.3 Hz $\leftarrow \rightarrow$ CLV, AOLV/PM, CLV/PM: 200% at 0.0 r/min $\leftarrow \rightarrow$ OLV/PM: 100% at 3 Hz
Speed Control Range $\leftarrow \rightarrow$	V/f, V/f w/PG: 1:40 OLV: 1:200 CLV, CLV/PM: 1:1500 OLV/PM: 1:20 AOLV/PM: 1:100
Speed Control Accuracy $\leftarrow \rightarrow$	OLV: $\pm 0.2\%$ (25 °C ± 10 °C) CLV: $\pm 0.02\%$ (25 °C ± 10 °C)
Speed Response $\leftarrow \rightarrow$	OLV, OLV/PM, AOLV/PM: 10 Hz (25 °C ± 10 °C (77 °F ± 50 °F)) CLV, CLV/PM: 50 Hz (25 °C ± 10 °C (77 °F ± 50 °F))
Torque Limit	Parameters setting allow separate limits in four quadrants (available in OLV, CLV, AOLV/PM, CLV/PM)
Accel/Decel Time	0.0 to 6000.0 s (4 selectable combinations of independent acceleration and deceleration settings)
Braking Torque	Approx. 20% (approx. 125% when using braking resistor) $\leftarrow \rightarrow$ <ul style="list-style-type: none"> • Short-time decel torque $\leftarrow \rightarrow$: over 100% for 0.4/ 0.75 kW motors, over 50% for 1.5 kW motors, and over 20% for 2.2 kW and above motors $\leftarrow \rightarrow$ (overexcitation braking/High Slip Braking: approx. 40%) • Continuous regenerative torque: approx. 20% $\leftarrow \rightarrow$ (approx. 125% with dynamic braking resistor option $\leftarrow \rightarrow$: 10% ED, 10s)
V/f Characteristics	User-selected programs and V/f preset patterns possible
Main Control Functions	Torque Control, Droop Control, Speed/torque Control Switching, Feed Forward Control, Zero Servo Function, Momentary Power Loss Ride-Thru, Speed Search, Overtorque/Undertorque Detection, Torque Limit, 17 Step Speed (max), Accel/decel Switch, S-curve Accel/decel, 3-wire Sequence, Auto-Tuning (rotational, stationary tuning), Dwell, Cooling Fan on/off Switch, Slip Compensation, Torque Compensation, Frequency Jump, Upper/lower Limits for Frequency Reference, DC Injection Braking at Start and Stop, Overexcitation Braking, High Slip Braking, PID Control (with sleep function), Energy Saving Control, MEMOBUS/Modbus Comm. (RS-422/RS-485 max, 115.2 kbps), Fault Restart, Application Presets, DriveWorksEZ (customized function), Removable Terminal Block with Parameter Backup Function, Online Tuning, KEB, Overexcitation Deceleration, Inertia (ASR) Tuning, Overvoltage Suppression, High Frequency Injection.

Item		Specification
Protection Functions	Motor Protection	Electronic thermal overload relay
	Momentary Overcurrent Protection	Drive stops when output current exceeds 200% of Heavy Duty Rating
	Overload Protection	Drive stops after 60 s at 150% of rated Heavy Duty output current <6>
	Overvoltage Protection	Stops when DC bus voltage exceeds approx. 820 V
	Undervoltage Protection	Stops when DC bus voltage falls below approx. 380 V
	Momentary Power Loss Ride-Thru	Immediately stop after 15 ms or longer power loss <7> . Continuous operation during power loss than 2 s (standard)
	Heatsink Overheat Protection	Thermistor
	Braking Resistor Overheat Protection	Overheat input signal for braking resistor (Optional ERF-type, 3% ED)
	Stall Prevention	Stall Prevention is available during acceleration, deceleration, and during run.
	Ground Protection	Electronic circuit protection <8>
DC Bus Charge LED	Remains lit until DC bus voltage falls below 50 V	
Environment	Area of Use	Indoors
	Ambient Temperature	Flange Type Enclosure: -10 °C to +40 °C (14 °F to 104 °F) Non-Flange Type Enclosure: -10 °C to +50 °C (14 °F to 122 °F)
	Humidity	95 RH% or less (no condensation)
	Storage Temperature	-20 °C to +60 °C (short-term temperature during transportation)
	Altitude	Up to 1000 meters without derating, up to 3000 m with output current and voltage derating.
	Vibration/Shock	10 Hz to 20 Hz: 9.8 m/s ² 20 Hz to 55 Hz: 5.9 m/s ² (4T0058□ to 4T0165□) or 2.0 m/s ² (4T0208□ to 4T0675□)
	Standard	<ul style="list-style-type: none"> • UL508C • IEC/EN 61800-3, IEC/EN 61800-5-1 • Two Safe Disable inputs and one EDM output according to ISO/EN 13849-1 Cat. 3 PLd, IEC/EN 61508 SIL2
	Protection Design	Flange Type Enclosure (NEMA Type 12 Backside) Open-Type (Non-Flange) Enclosure

<1> Select control modes in accordance with drive capacity.

<2> The accuracy of these values depends on motor characteristics, ambient conditions, and drive settings. Specifications may vary with different motors and with changing motor temperature. Contact Yaskawa for consultation.

<3> Disable Stall Prevention during deceleration (L3-04 = 0) when using a regenerative converter, a regenerative unit, a braking resistor or the Braking Resistor Unit. The default setting for the Stall Prevention function will interfere with the braking resistor.

<4> Instantaneous average deceleration torque refers to the torque required to decelerate the motor (uncoupled from the load) from the rated motor speed down to zero in the shortest time.

<5> Actual specifications may vary depending on motor characteristics.

<6> Overload protection may be triggered when operating with 150% of the rated output current if the output frequency is less than 6 Hz.

<7> May be shorter due to load conditions and motor speed.

<8> Ground protection cannot be provided when the impedance of the ground fault path is too low, or when the drive is powered up while a ground fault is present at the output.

8 Specifications

◆ Drive Watt Loss Data

Table 10 Drive Watt Loss

Drive Model	Normal Duty				Heavy Duty			
	Rated Amps (A) <3>	Internal	External	Total	Rated Amps (A)	Internal	External	Total
4T0058□	58	197	453	650	45 <1>	159	341	500
4T0072□	72	244	588	832	60 <1>	206	477	683
4T0088□	88	285	669	954	75 <1>	241	556	797
4T0103□	103	329	827	1156	91 <1>	285	714	999
4T0139□	139	487	1179	1666	112 <1>	447	1100	1547
4T0165□	165	624	1520	2164	150 <2>	629	1647	2276
4T0208□	208	553	1746	2299	180 <2>	586	2199	2765
4T0250□	250	729	2305	3034	216 <2>	663	2308	2971
4T0296□	296	772	2308	3080	260 <2>	694	2295	2989
4T0362□	362	874	3168	4042	304 <2>	788	3075	3863
4T0414□	414	1083	3443	4526	370 <1>	1012	3578	4590
4T0515□	515	1474	4850	6324	450 <1>	1234	3972	5206
4T0675□	675	1789	4861	6650	605 <1>	1504	4191	5695

<1> Value assumes the carrier frequency is set to 8 kHz or less.

<2> Value assumes the carrier frequency is set to 5 kHz or less.

<3> Value assumes the carrier frequency is set to 2 kHz.

◆ Drive Derating Data

■ Temperature Derating

To ensure the maximum performance life, the drive output current must be derated as shown in *Figure 21* when the drive is installed in areas with high ambient temperature or if drives are mounted side-by-side in a cabinet. Set parameter L8-35 to 3 for all 6-Phase/12-Pulse Flange and Non-Flange models to ensure reliable drive overload protection.

■ Parameter Settings

No.	Name	Description	Range	Def.
L8-12	Ambient Temperature Setting	Adjust the drive overload (oL2) protection level when the drive is installed in an environment that exceeds its ambient temperature rating.	-10 to +50	+40 °C
L8-35	Installation Method Selection	0: IP00/Open-Chassis Enclosure 1: Side-by-Side Mounting 2: IP20/NEMA Type 1 Enclosure 3: Finless Drive or External Heatsink Installation Note: Set this parameter to 3 for all 6-Phase/12-Pulse Flange and Non-Flange models.	0 to 3	<1>

<1> Set this parameter to 3 for all 6-Phase/12-Pulse Flange and Non-Flange models. Default setting is determined by drive model.

Setting 0: (Models 4T0208□ to 4T0675□)

Setting 2: (Models 4T0058□ to 4T0165□).

Setting 0: IP00/Open-Chassis Enclosure

Drive operation between -10 °C and +50 °C allows 100% continuous current without derating.

Setting 1: Side-by-Side Mounting

Drive operation between -10 °C and +30 °C allows 100% continuous current without derating. Operation between +30 °C and +50 °C requires output current derating.

Setting 2: IP20/NEMA Type 1 Enclosure

Drive operation between -10 °C and +40 °C allows 100% continuous current without derating. Operation between +40 °C and +50 °C requires output current derating.

Setting 3: External Heatsink Installation, Finless Drive

Drive operation between -10 °C and +40 °C allows 100% continuous current without derating. Operation between +40 °C and +50 °C requires output current derating.

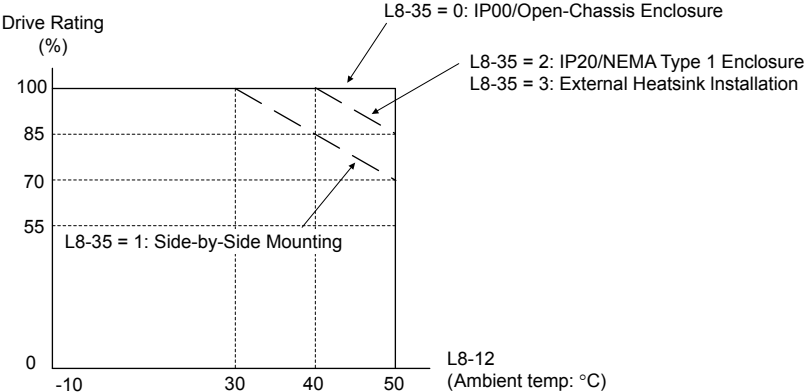

Figure 21 Ambient Temperature and Installation Method Derating

Altitude Derating

The drive standard ratings are valid for installation altitudes up to 1000 m. For installations from 1000 m to 3000 m, the drive rated voltage and the rated output current must be derated for 0.2% per 100 m.

◆ External Mounting and Panel Cutout Dimensions

Table 11 External Mounting and Panel Cutout Dimensions Reference

Model	External Mounting Dimensions Page	Panel Cutout Dimensions Page
Flange Type Models		
4T0058U	<i>45</i>	<i>61</i>
4T0072U	<i>46</i>	<i>62</i>
4T0088U	<i>47</i>	<i>63</i>
4T0103U		
4T0139U	<i>48</i>	<i>64</i>
4T0165U		
4T0208U	<i>49</i>	<i>65</i>
4T0250U	<i>50</i>	<i>66</i>
4T0296U		
4T0362U		
4T0414U	<i>51</i>	<i>67</i>
4T0515U	<i>52</i>	<i>68</i>
4T0675U		
Non-Flange Type Models		
4T0058A	<i>53</i>	<i>69</i>
4T0072A	<i>54</i>	<i>70</i>
4T0088A	<i>55</i>	<i>71</i>
4T0103A		
4T0139A	<i>56</i>	<i>72</i>
4T0165A		
4T0208A	<i>57</i>	<i>73</i>
4T0250A	<i>58</i>	<i>74</i>
4T0296A		
4T0362A		
4T0414A	<i>59</i>	<i>75</i>
4T0515A	<i>60</i>	<i>76</i>
4T0675A		

External Mounting Dimensions

Mounting Dimensions for Flange Type 4T□□□□U Models

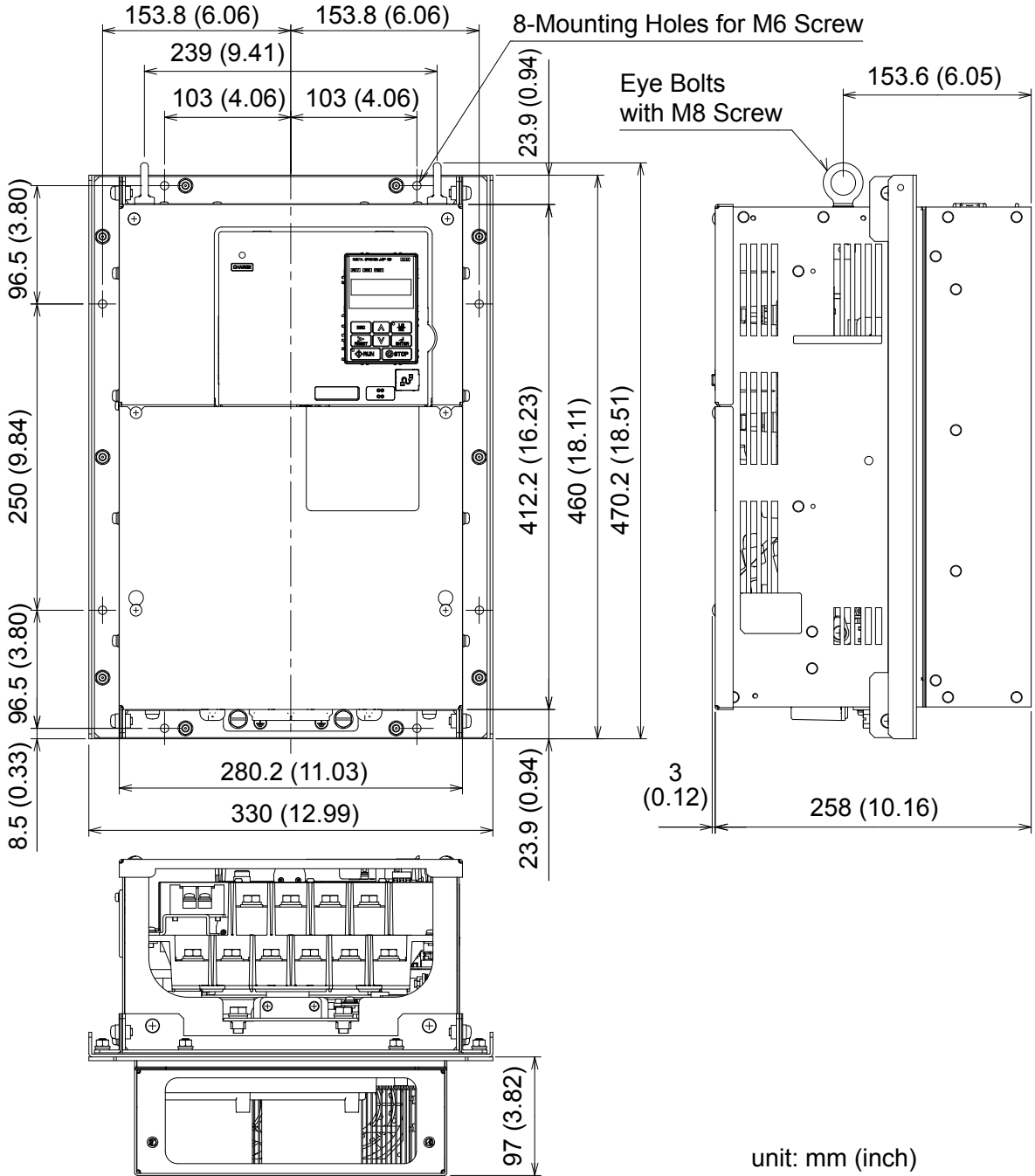

Figure 22 Flange Type Model 4T0058U Mounting Dimensions

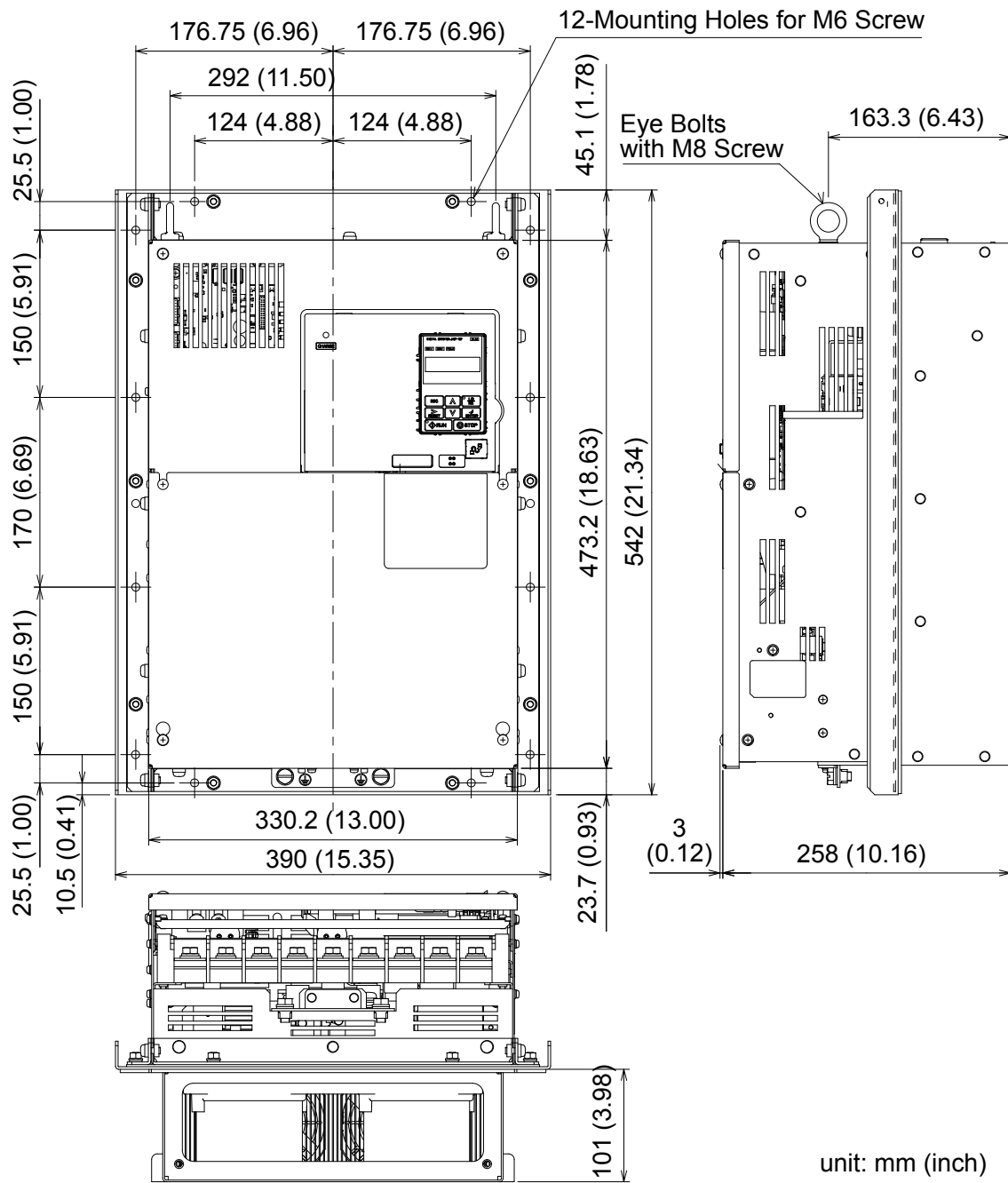

Figure 23 Flange Type Model 4T0072U Mounting Dimensions

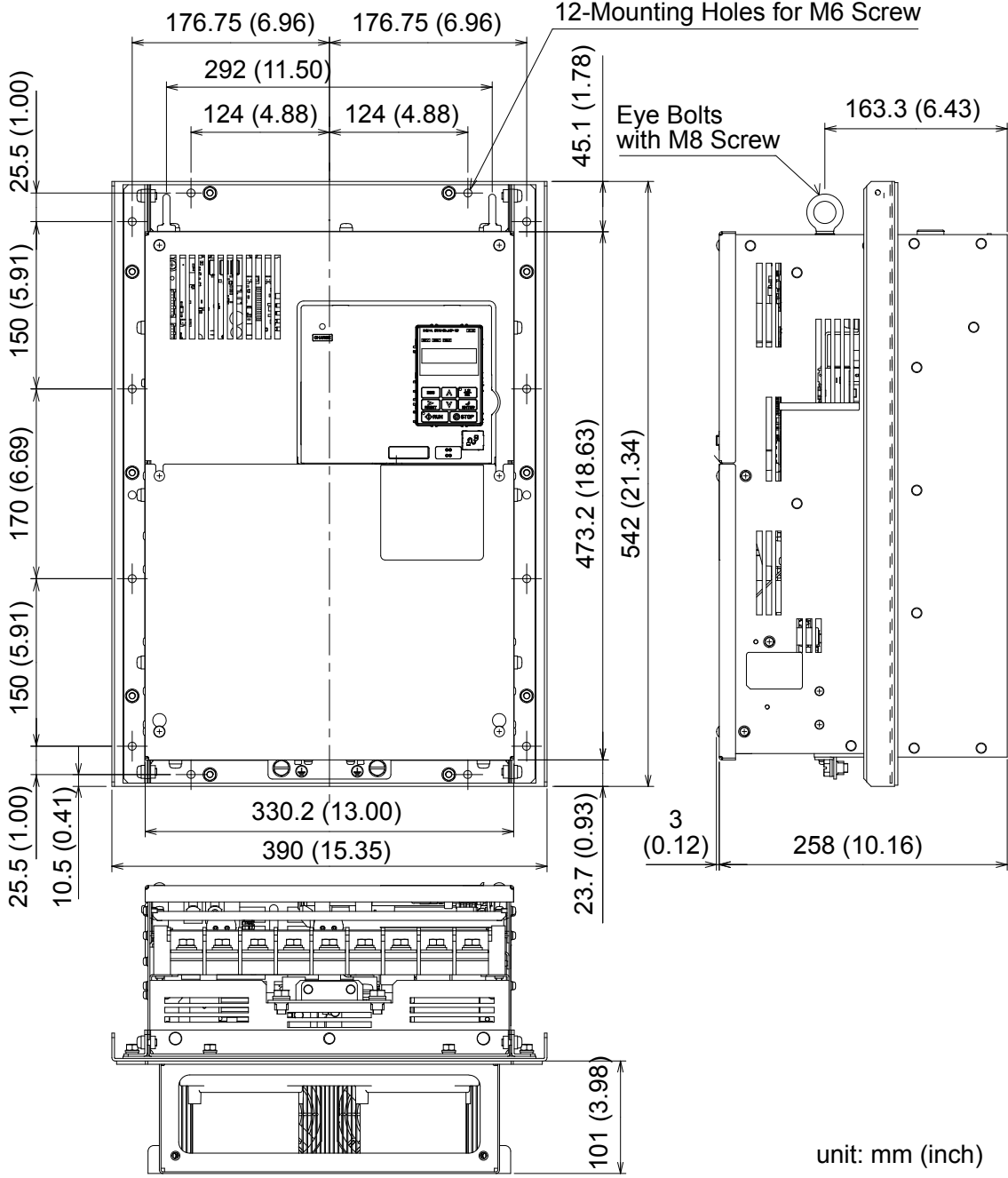

Figure 24 Flange Type Models 4T0088U and 4T0103U Mounting Dimensions

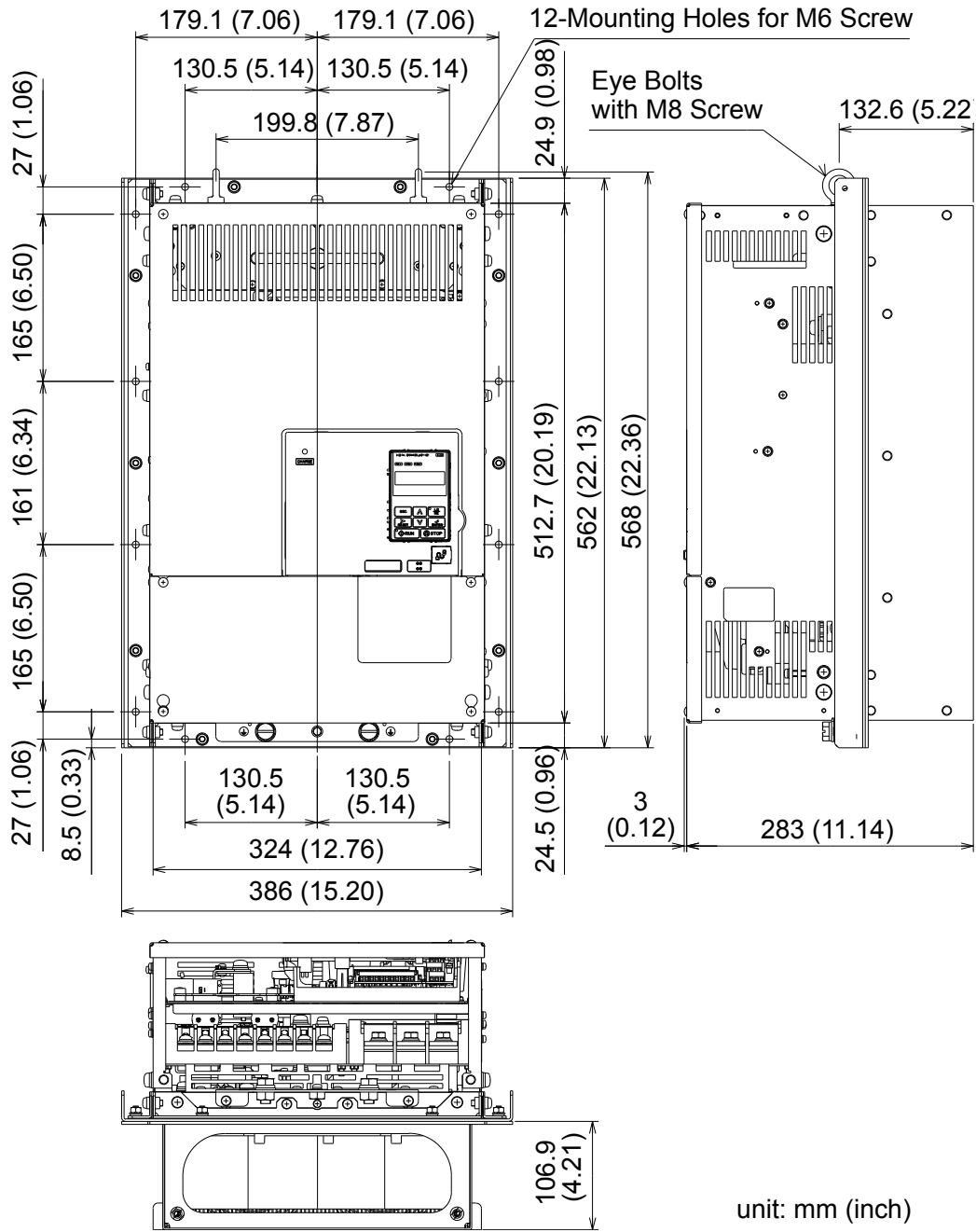

Figure 25 Flange Type Models 4T0139U and 4T0165U Mounting Dimensions

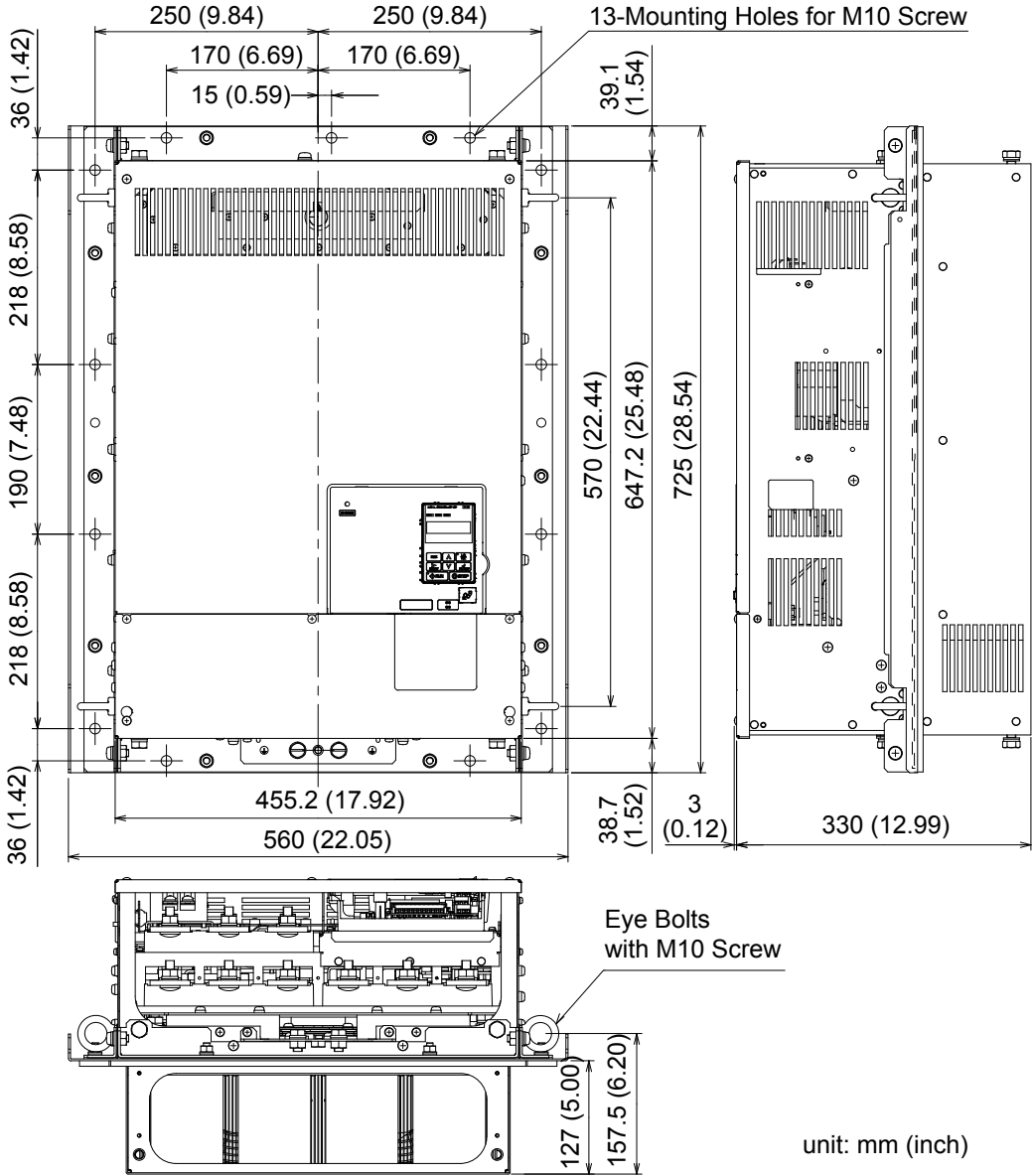

Figure 26 Flange Type Models 4T0208U Mounting Dimensions

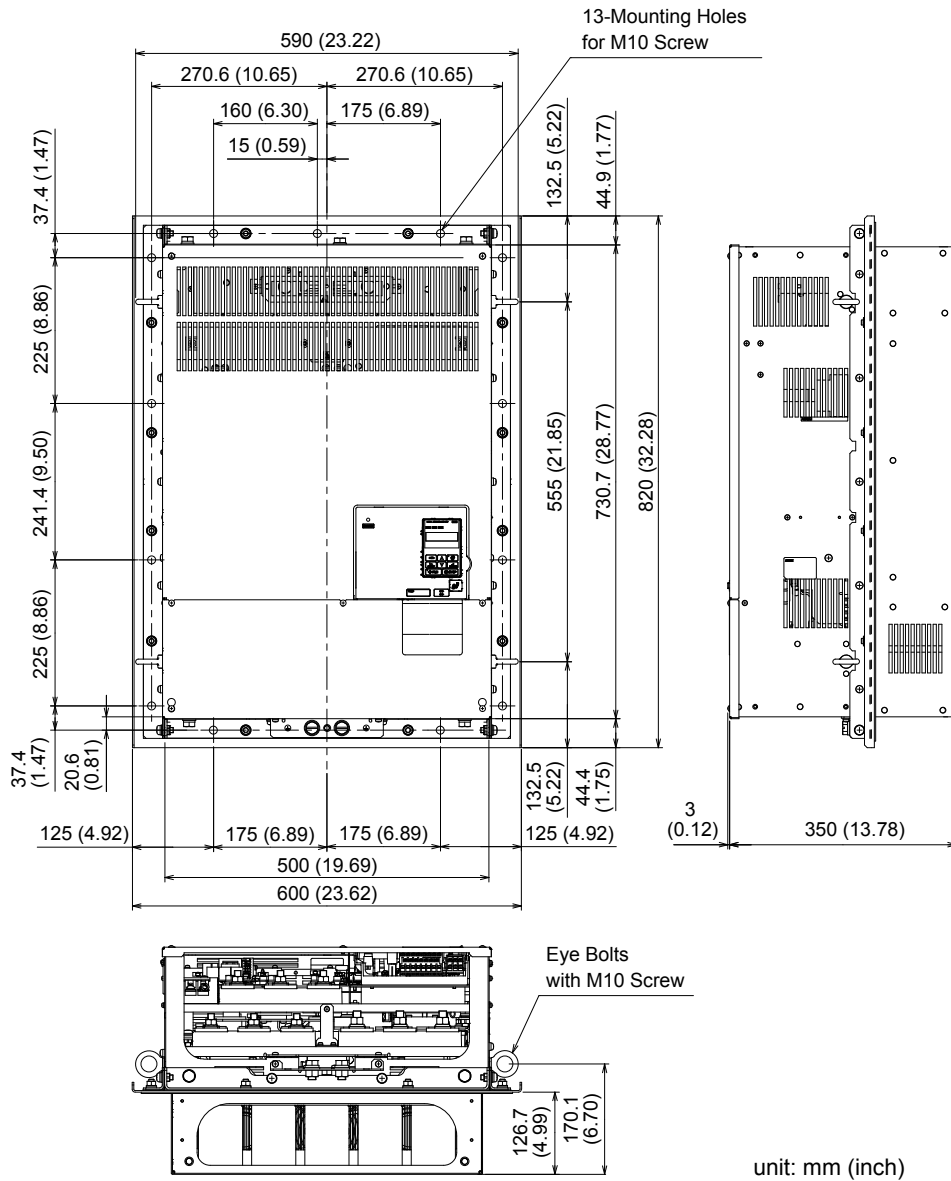

Figure 27 Flange Type Models 4T0250U to 4T0362U Mounting Dimensions

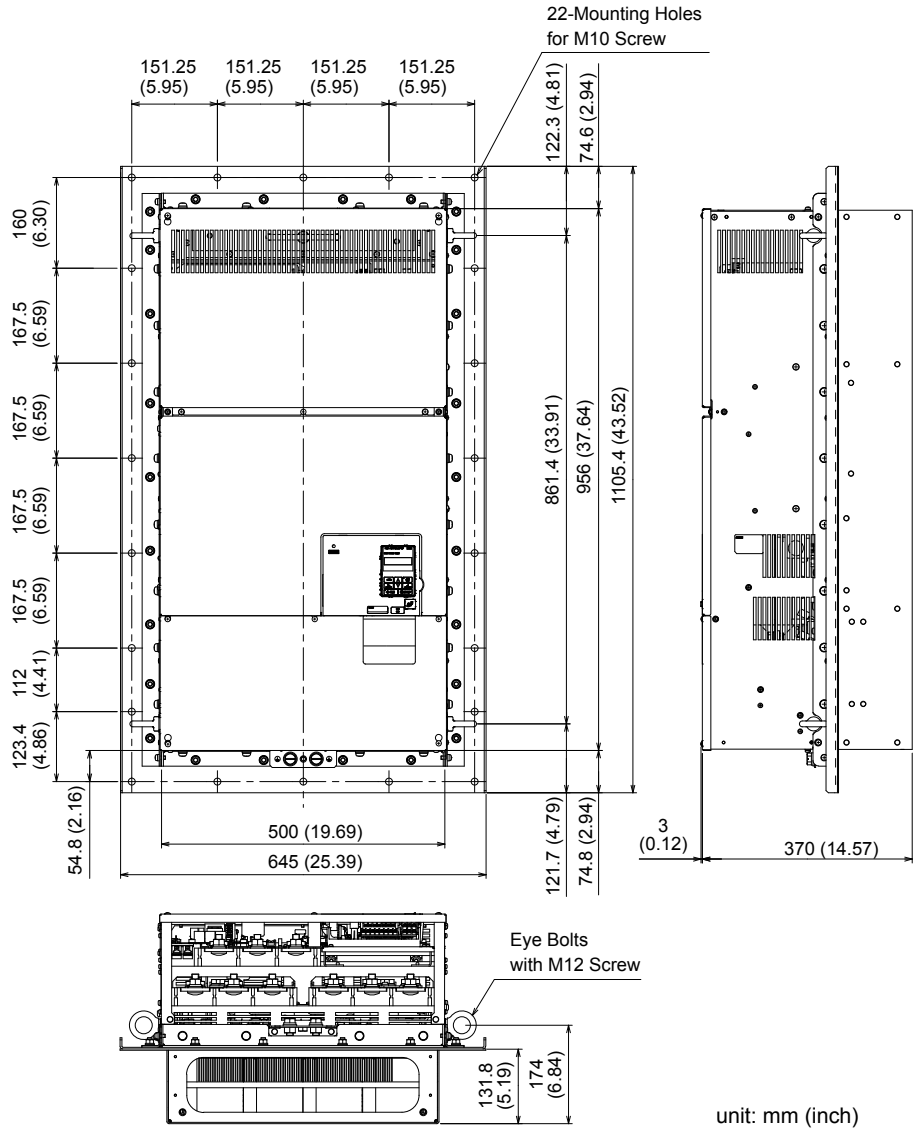

Figure 28 Flange Type Model 4T0414U Mounting Dimensions

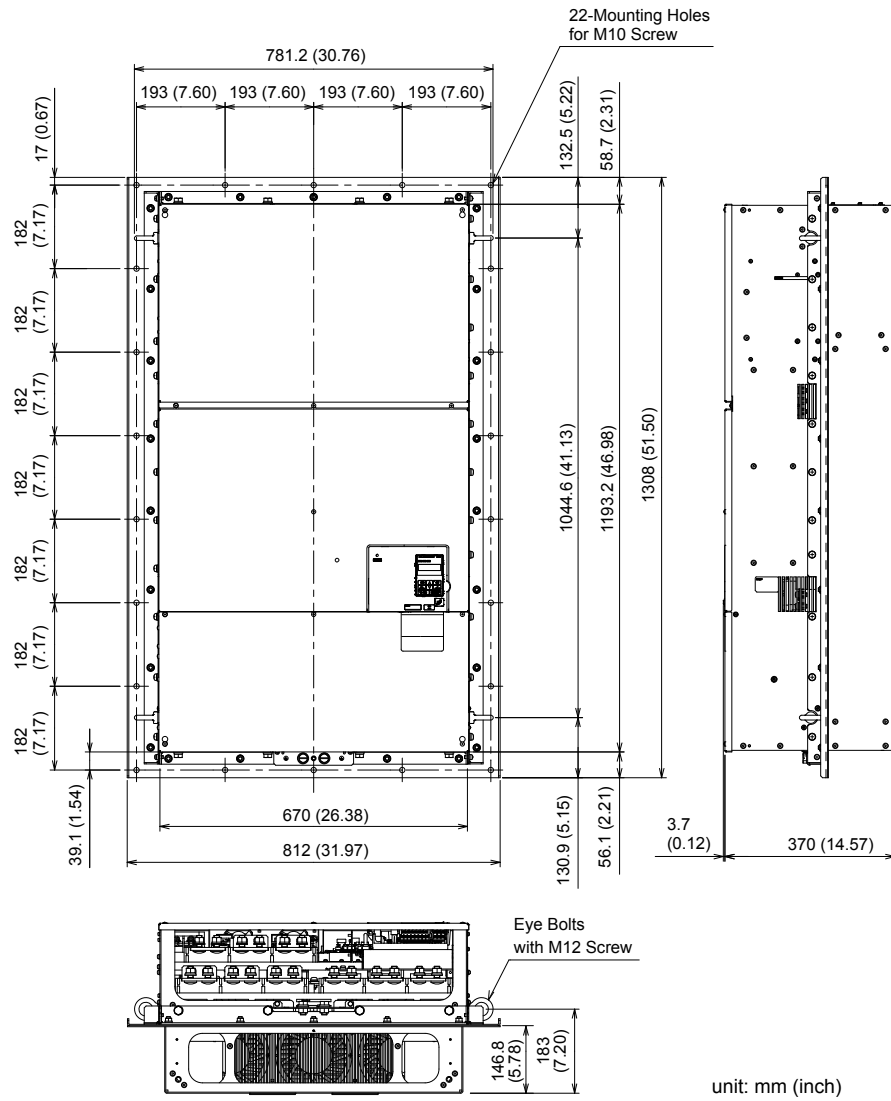

Figure 29 Flange Type Models 4T0515U and 4T6075U Mounting Dimensions

Mounting Dimensions for Non-Flange Type 4T□□□□A Models

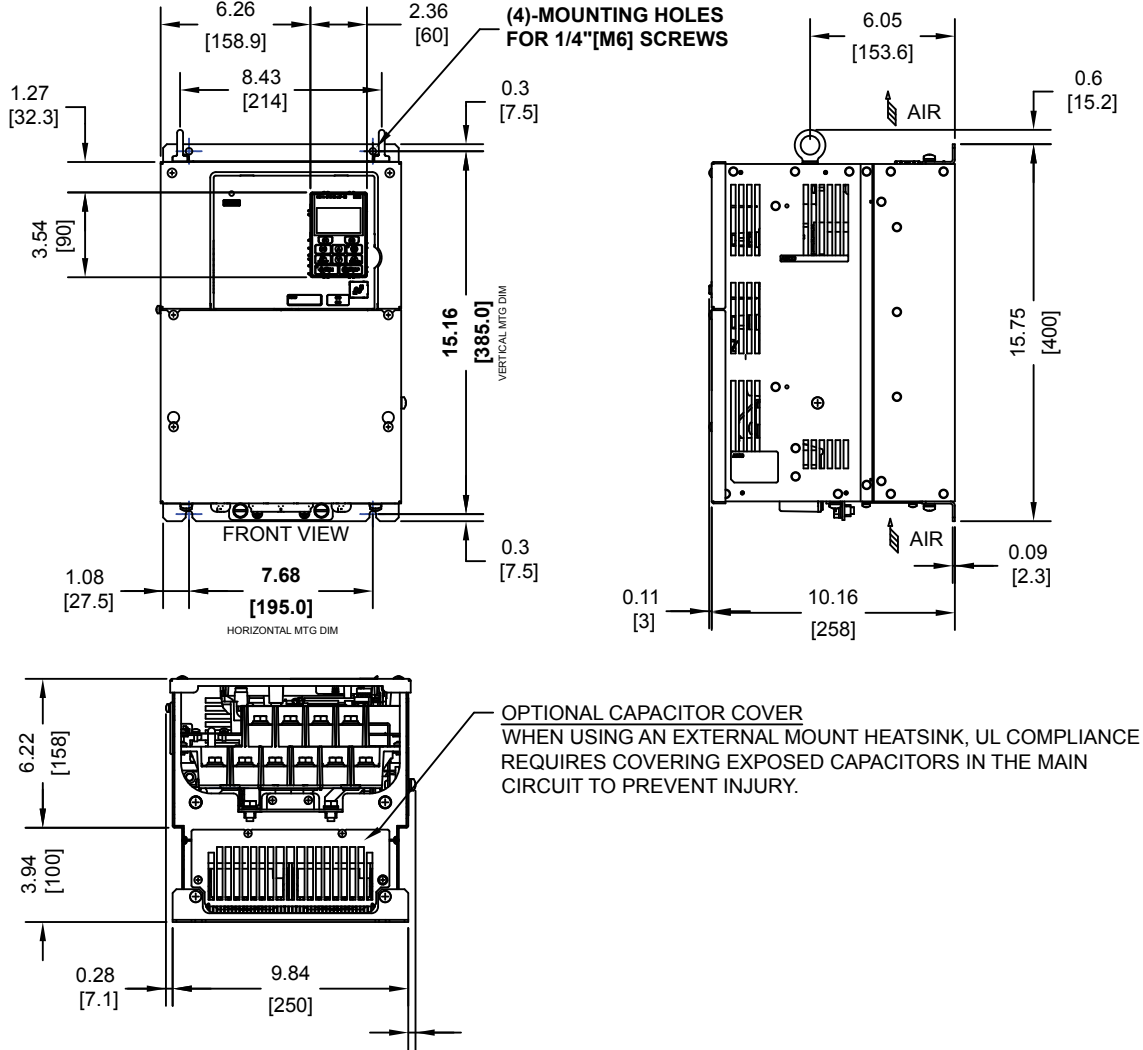

Figure 30 Non-Flange Type Model 4T0058A Mounting Dimensions

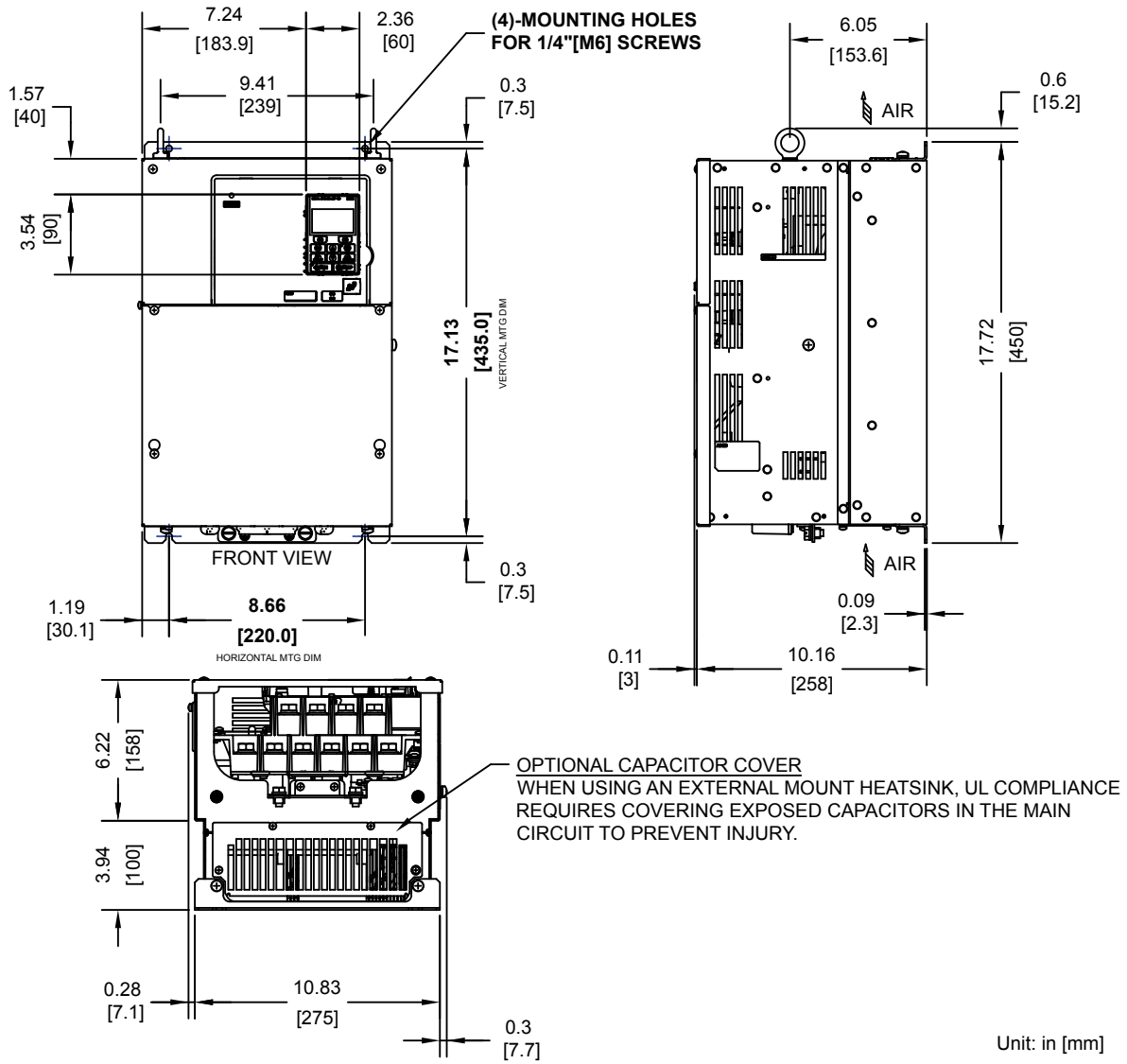

Figure 31 Non-Flange Type Model 4T0072A Mounting Dimensions

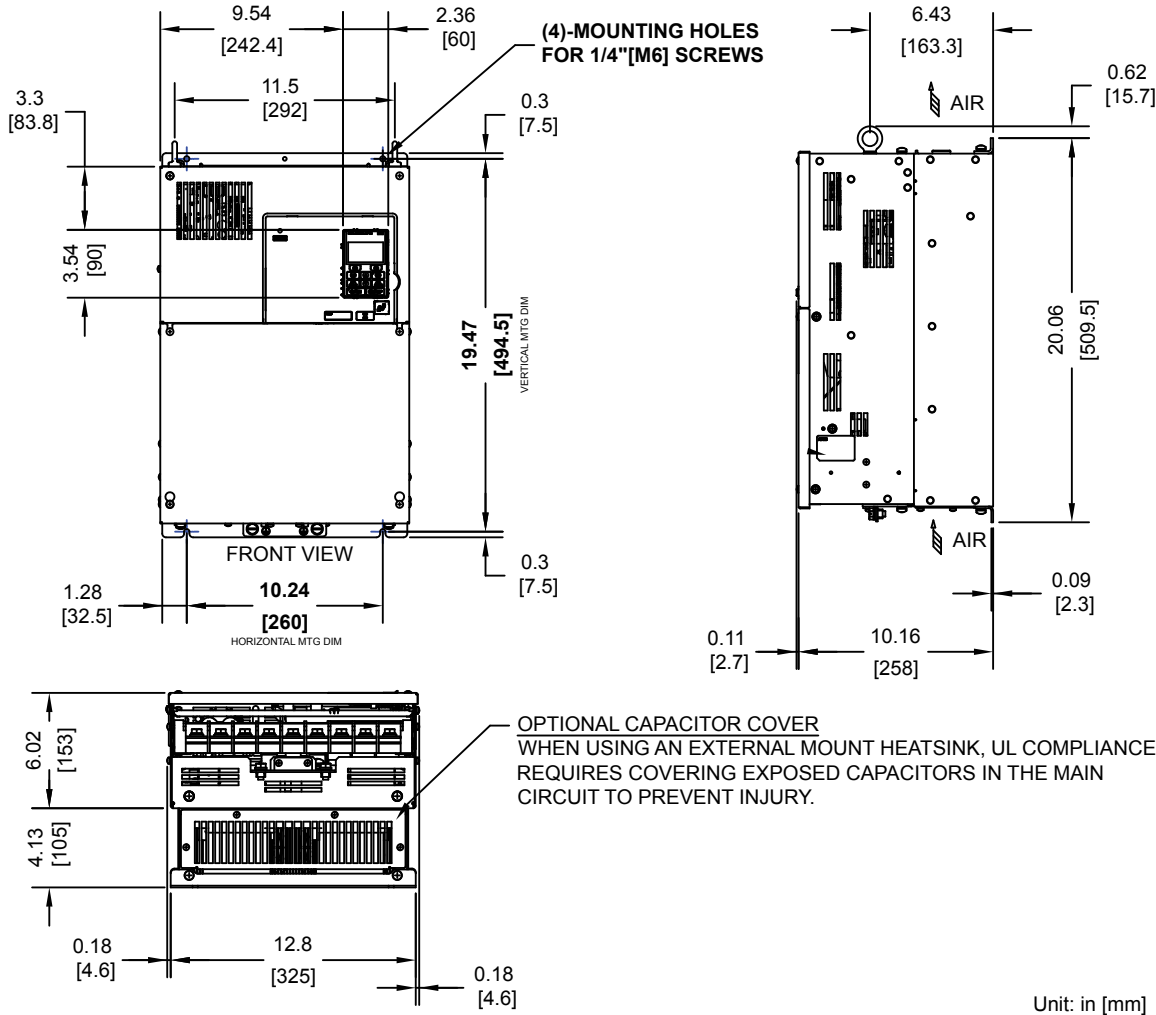

Figure 32 Non-Flange Type Models 4T0088A and 4T0103A Mounting Dimensions

8 Specifications

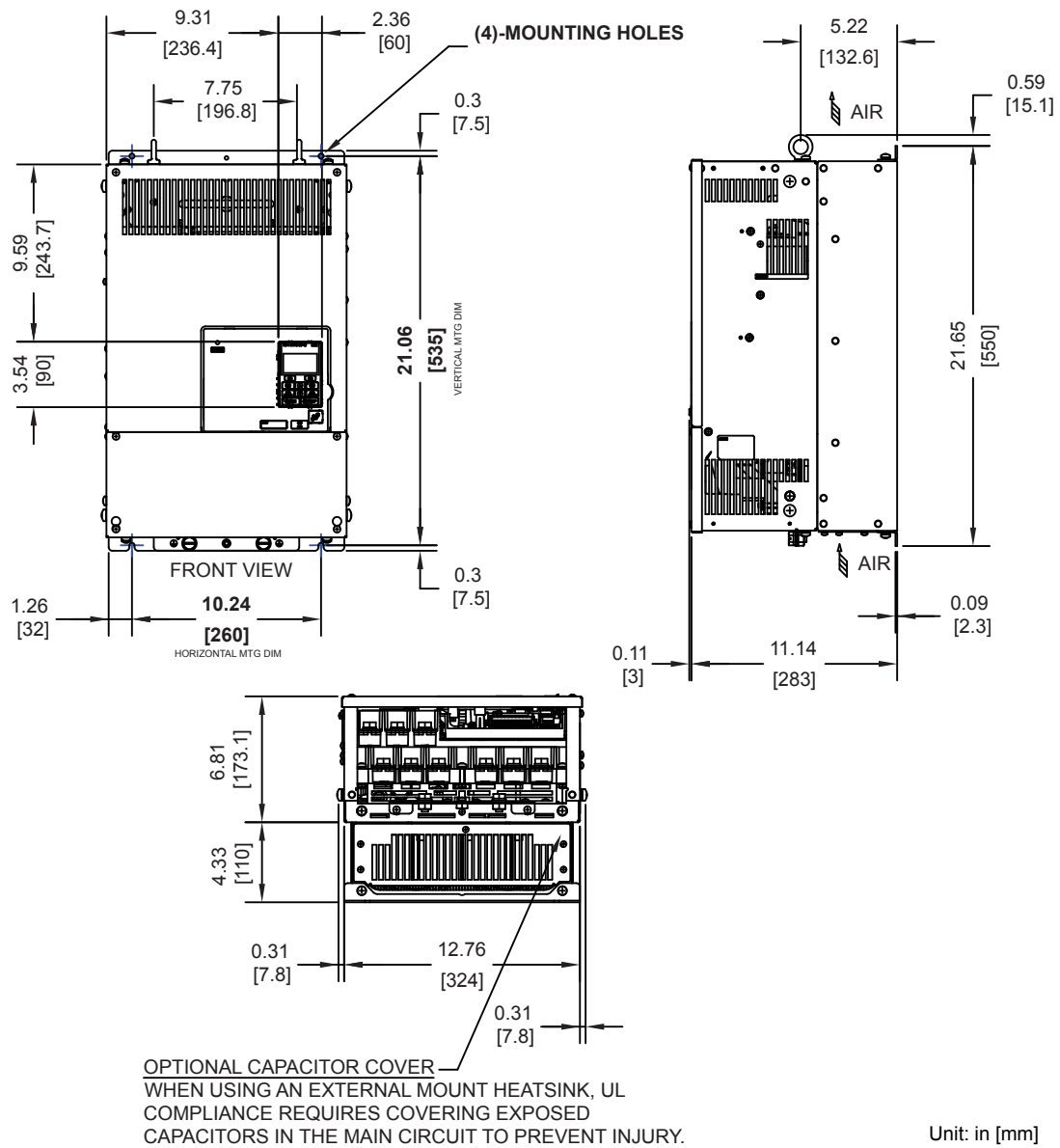

Figure 33 Non-Flange Type Models 4T0139A and 4T0165A Mounting Dimensions

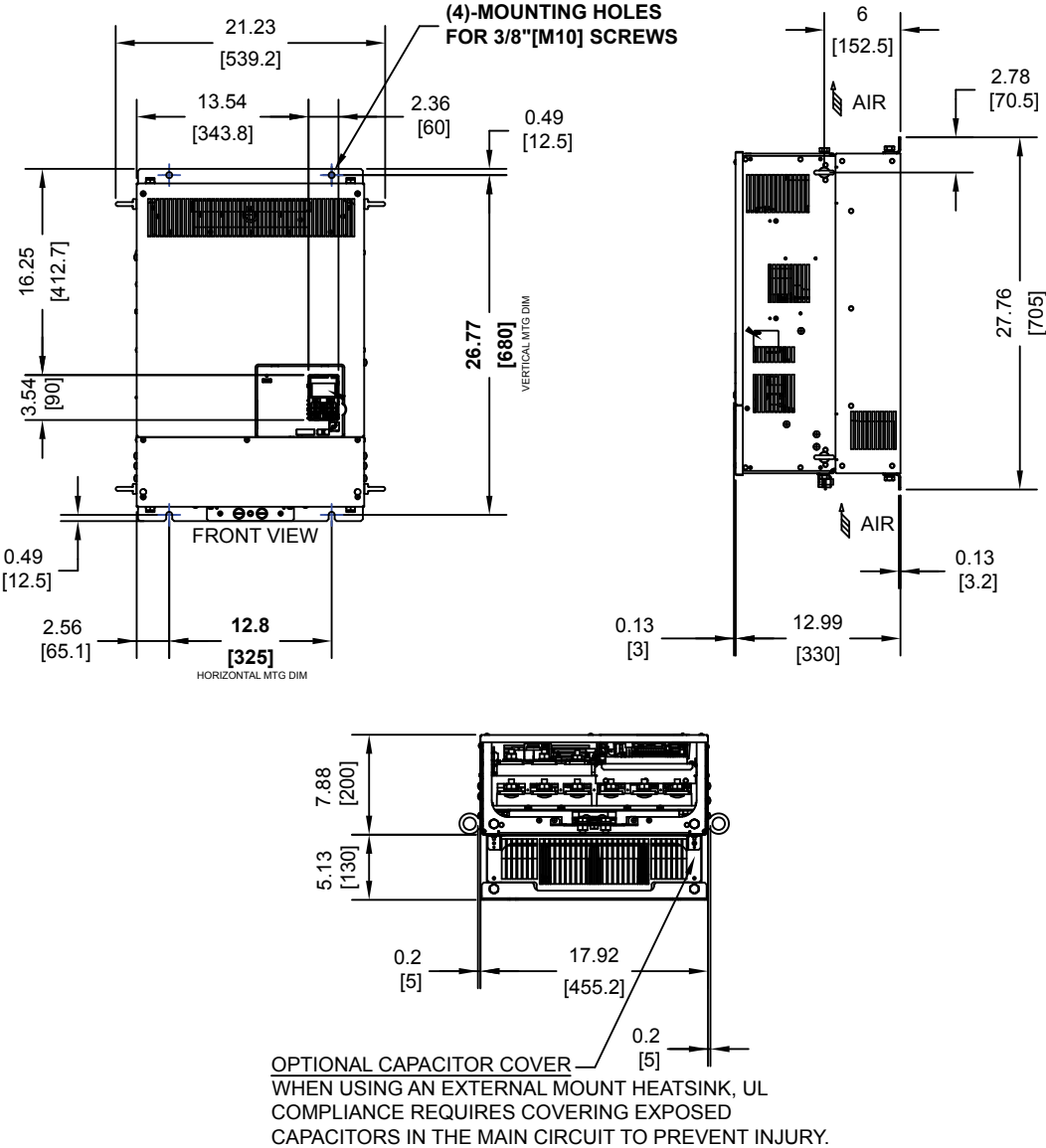

Figure 34 Non-Flange Type Models 4T0208A Mounting Dimensions

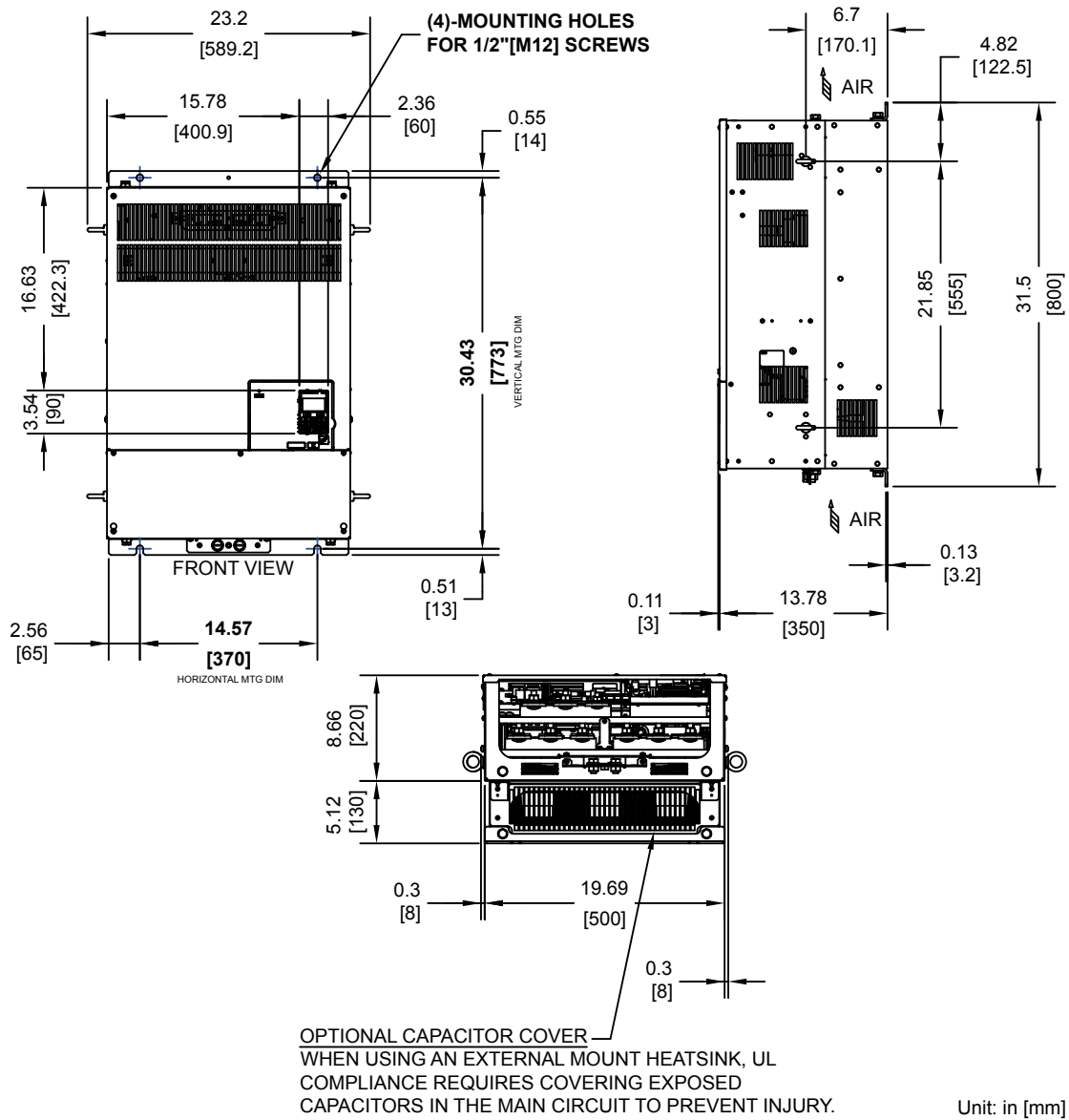

Figure 35 Non-Flange Type Models 4T0250A to 4T0362A Mounting Dimensions

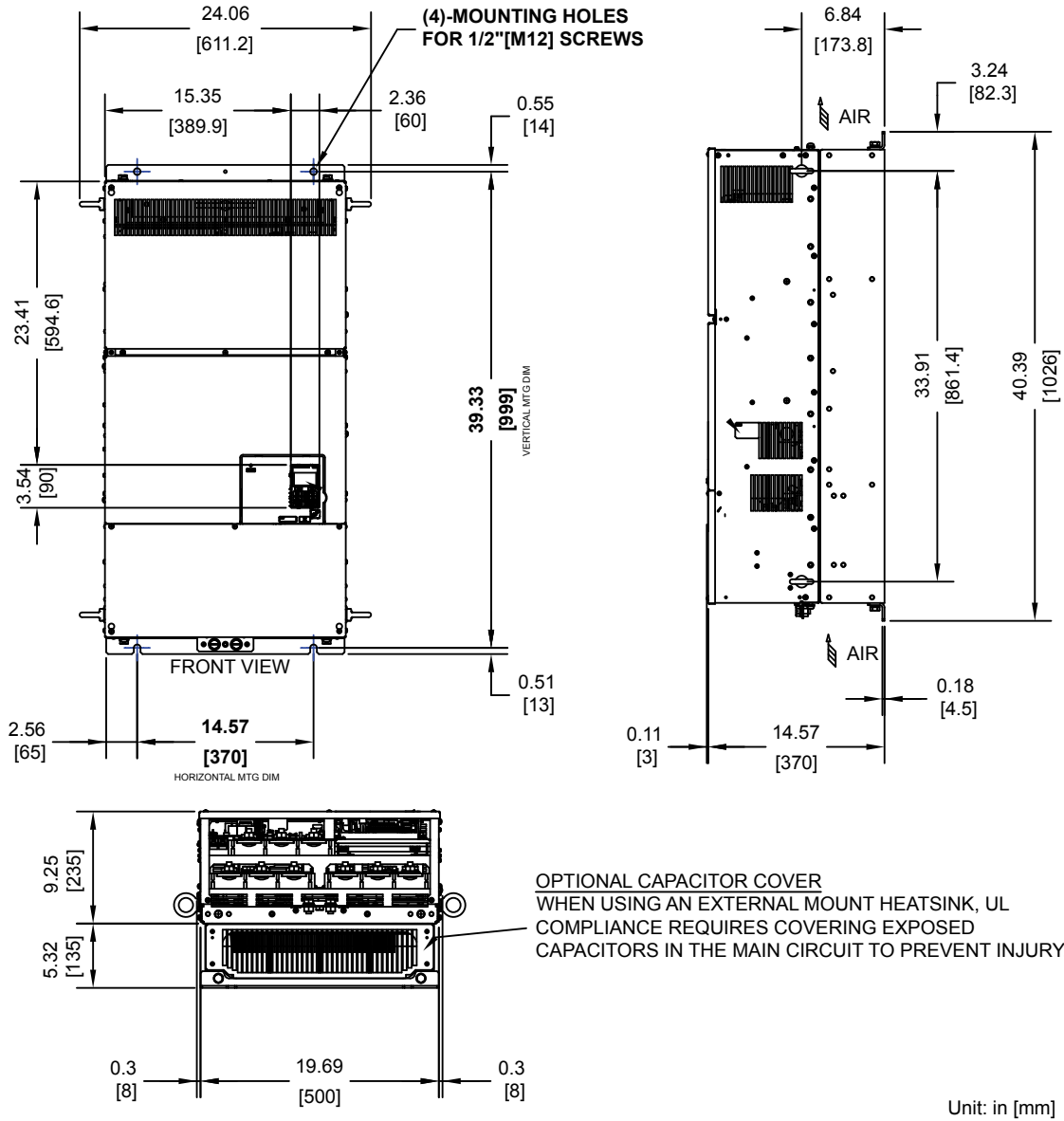

Figure 36 Non-Flange Type Model 4T0414A Mounting Dimensions

8 Specifications

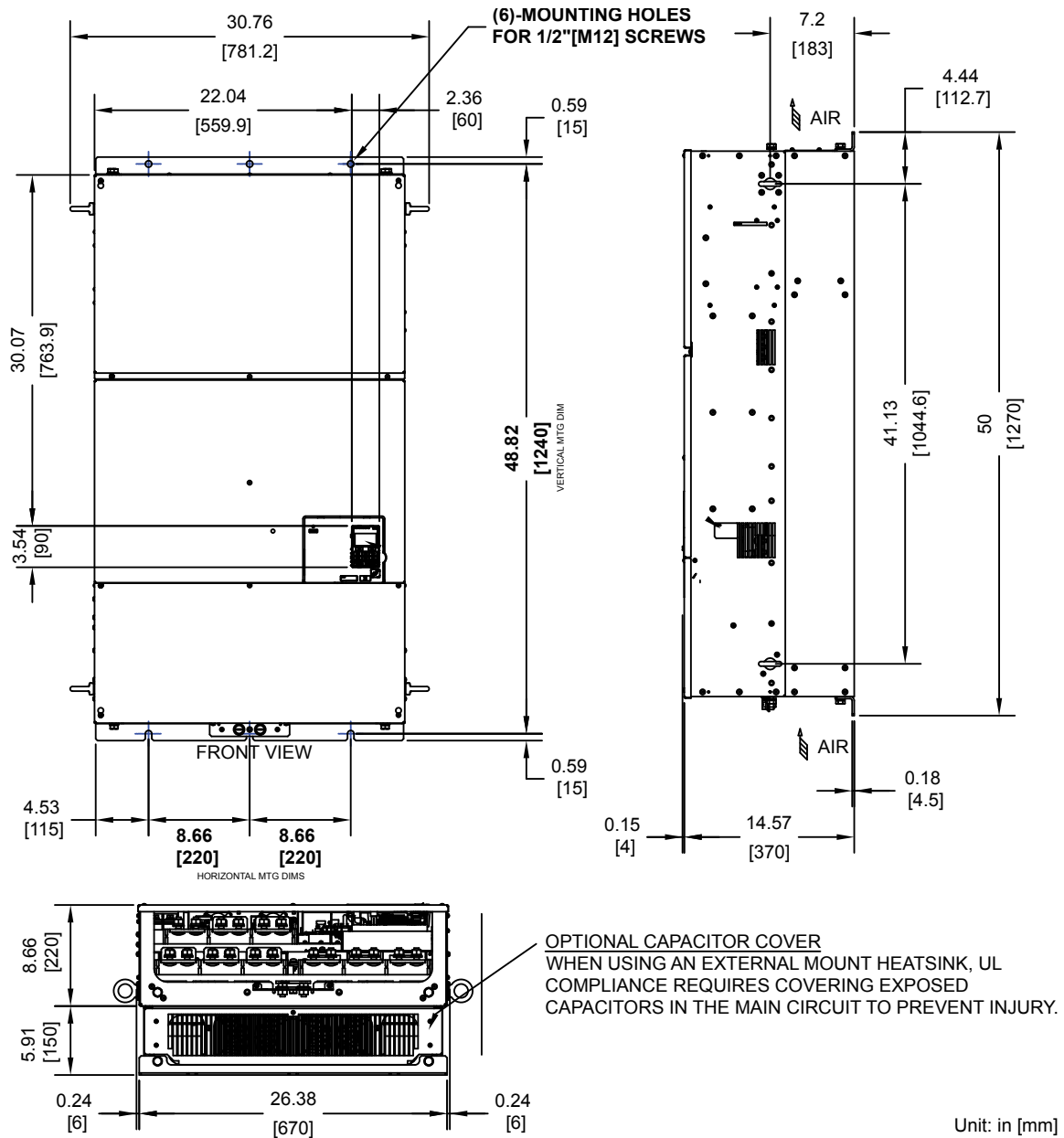
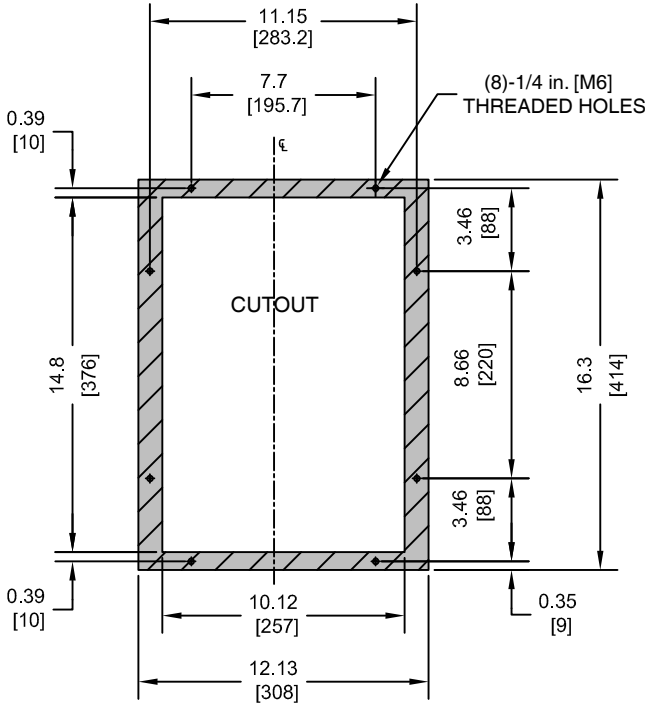

Figure 37 Non-Flange Type Models 4T0515A and 4T6075A Mounting Dimensions

■ Panel Cutout Dimensions

Panel Cutout Dimensions for Flange Type 4T□□□□U Models



- NOTES:**
- 1. CUTOUT TOLERANCES:
+/- 0.02 in. [0.5 mm]
 - 2. EXPOSED HEATSINK DEPTH
D=3.82 in. [97 mm] MINUS PANEL THICKNESS
 - 3. MINIMUM RECOMMENDED PANEL THICKNESS: 12 GA
- Unit: in. [mm]

Figure 38 Flange Type Model 4T0058U Panel Cutout Dimensions

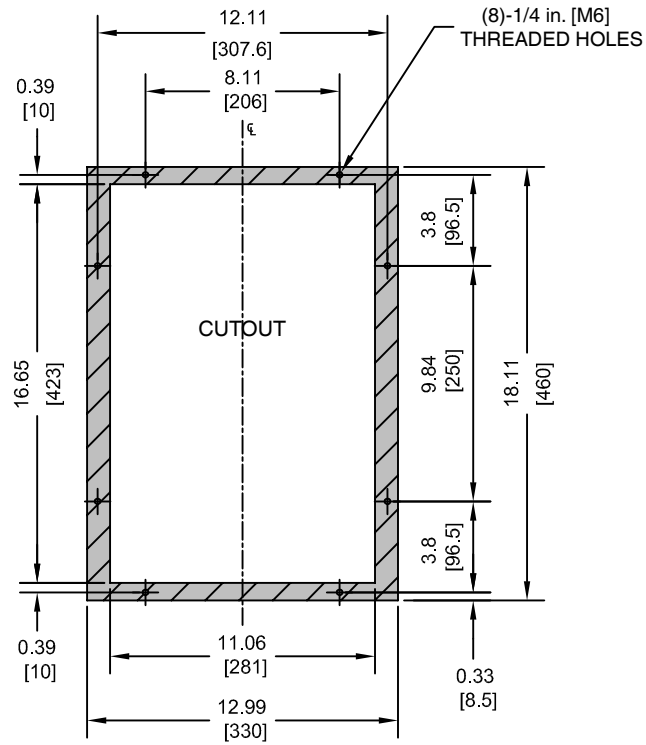

- NOTES:**
1. CUTOUT TOLERANCES:
+/- 0.02 in. [0.5 mm]
 2. EXPOSED HEATSINK DEPTH
D=3.81 in. [97 mm] MINUS PANEL THICKNESS
 3. MINIMUM RECOMMENDED PANEL THICKNESS: 12 GA
- Unit: in. [mm]

Figure 39 Flange Type Model 4T0072U Panel Cutout Dimensions

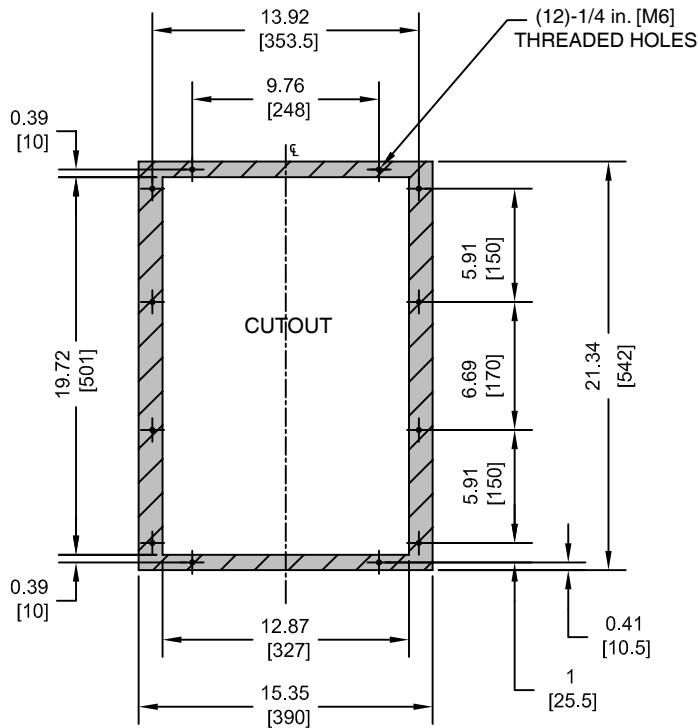

- NOTES:**
- 1. CUTOUT TOLERANCES:
+/- 0.02 in. [0.5 mm]
 - 2. EXPOSED HEATSINK DEPTH
D=3.97 in. [101 mm] MINUS PANEL THICKNESS
 - 3. MINIMUM RECOMMENDED PANEL THICKNESS: 12 GA
- Unit: in. [mm]

Figure 40 Flange Type Models 4T0088U and 4T0103U Panel Cutout Dimensions

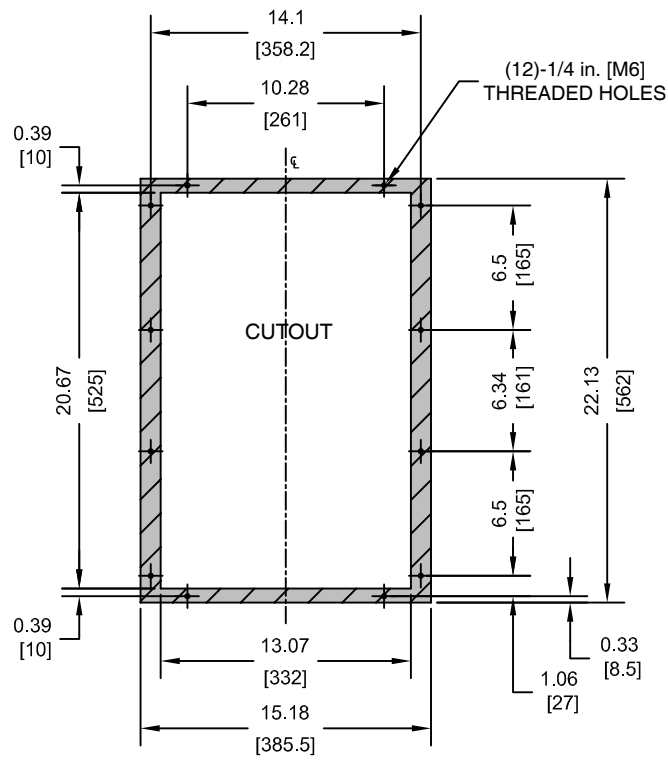

- NOTES:
- CUTOUT TOLERANCES:
+/- 0.02 in. [0.5 mm]
 - EXPOSED HEATSINK DEPTH
D=4.21 in. [107 mm] MINUS PANEL THICKNESS
 - MINIMUM RECOMMENDED PANEL THICKNESS: 12 GA
- Unit: in. [mm]

Figure 41 Flange Type Models 4T0139U and 4T0165U Panel Cutout Dimensions

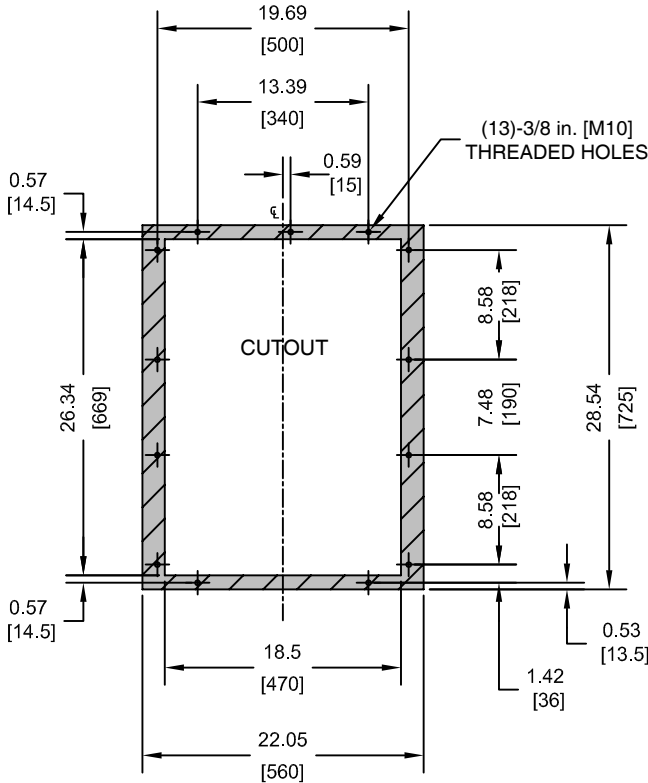

- NOTES:**
- 1. CUTOUT TOLERANCES:
+/- 0.02 in. [0.5 mm]
 - 2. EXPOSED HEATSINK DEPTH
D=5.00 in. [127 mm] MINUS PANEL THICKNESS
 - 3. MINIMUM RECOMMENDED PANEL THICKNESS: 10 GA
- Unit: in. [mm]

Figure 42 Flange Type Model 4T0208U Panel Cutout Dimensions

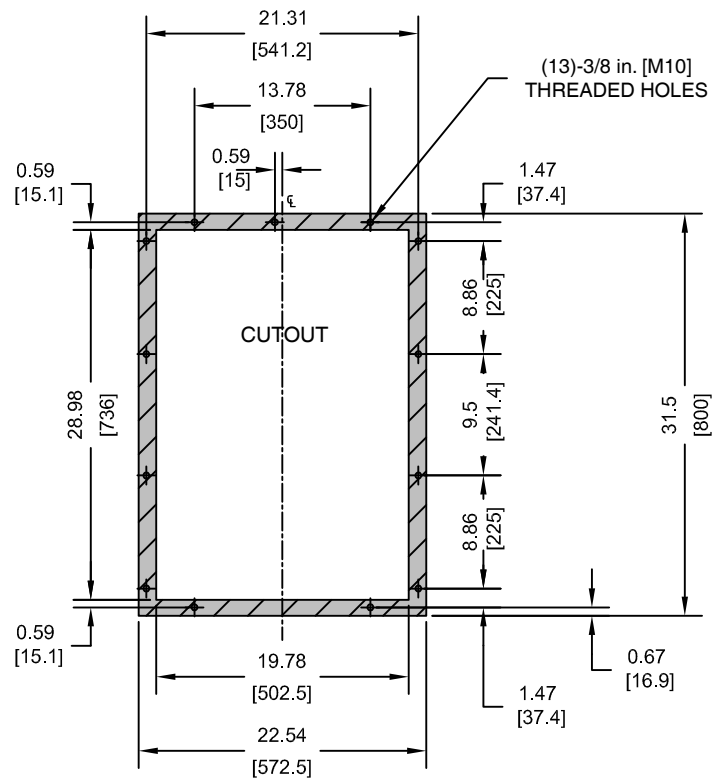

NOTES:

1. CUTOUT TOLERANCES:

+/- 0.02 in. [0.5 mm]

2. EXPOSED HEATSINK DEPTH

D=4.99 in. [127 mm] MINUS PANEL THICKNESS

3. MINIMUM RECOMMENDED PANEL

THICKNESS: 10 GA

Unit: in. [mm]

Figure 43 Flange Type Models 4T0250U to 4T0362U Panel Cutout Dimensions

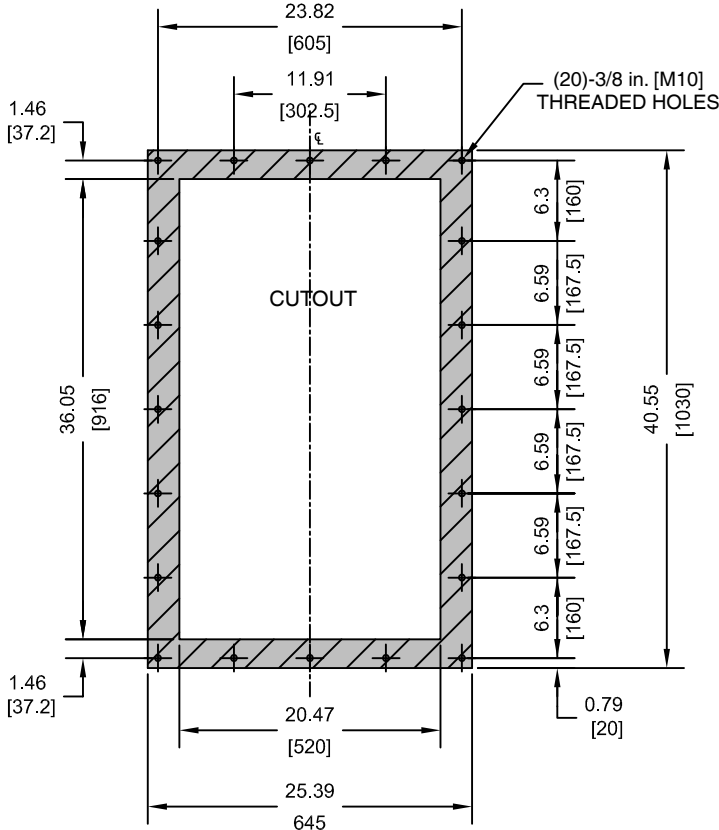

- NOTES:
1. CUTOUT TOLERANCES:
+/- 0.02 in. [0.5 mm]
 2. EXPOSED HEATSINK DEPTH
D=5.19 in. [132 mm] MINUS PANEL THICKNESS
 3. MINIMUM RECOMMENDED PANEL THICKNESS: 10 GA
- Unit: in. [mm]

Figure 44 Flange Type Model 4T0414U Panel Cutout Dimensions

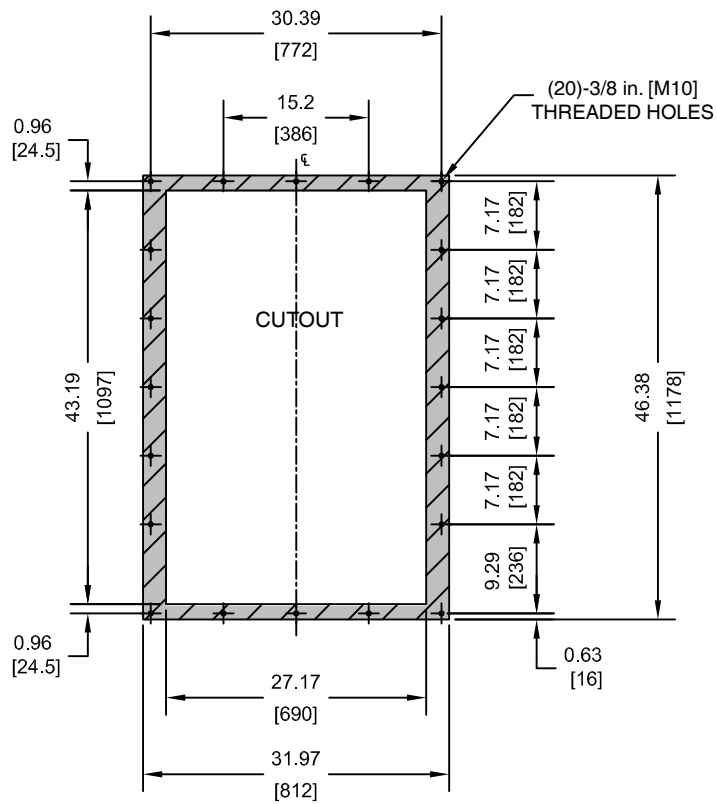

NOTES:

1. CUTOUT TOLERANCES:
+/- 0.02 in. [0.5 mm]
 2. EXPOSED HEATSINK DEPTH
D=7.71 in. [196 mm] MINUS PANEL THICKNESS
 3. MINIMUM RECOMMENDED PANEL THICKNESS: 10 GA
- Unit: in. [mm]

Figure 45 Flange Type Models 4T0515U and 4T0675U Panel Cutout Dimensions

Panel Cutout Dimensions for Non-Flange Type 4T□□□□A Models

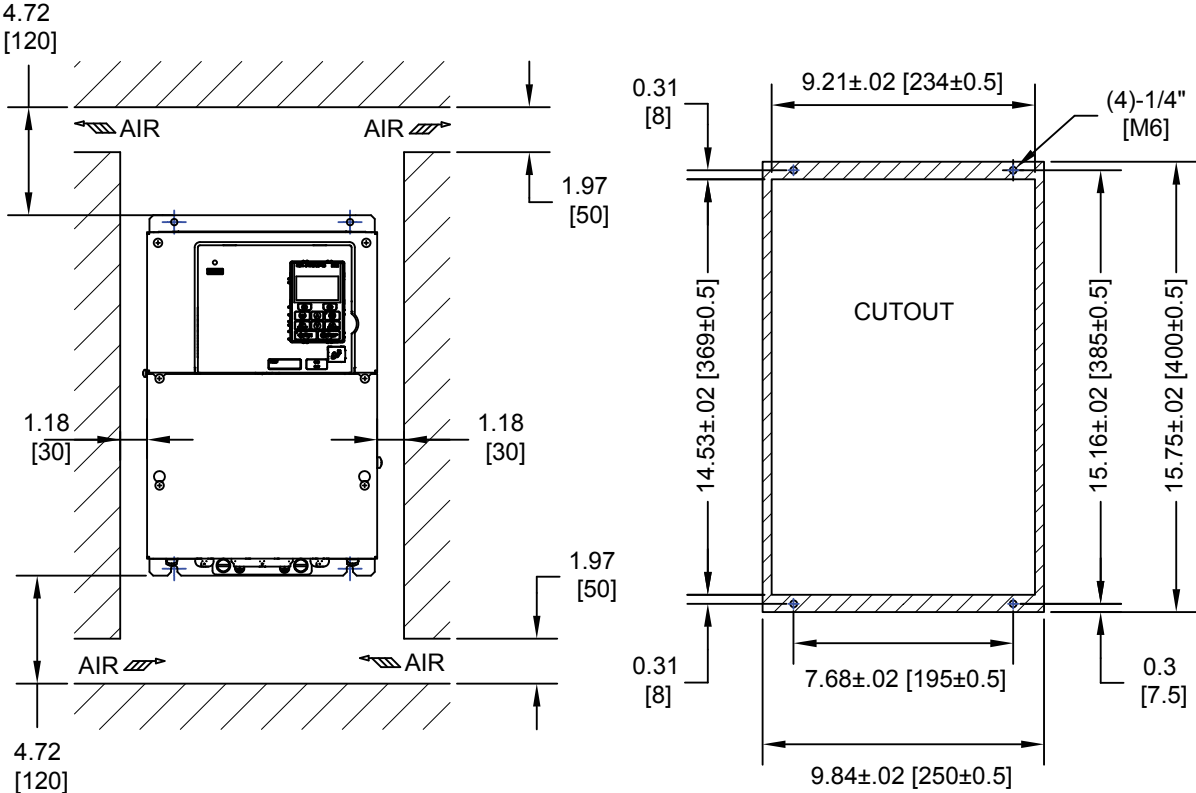

NOTE:
EXPOSED HEATSINK DEPTH
D=3.94" MINUS PANEL THICKNESS

Unit: in. [mm]

Figure 46 Non-Flange Type Model 4T0058A Clearances and Panel Cutout Dimensions

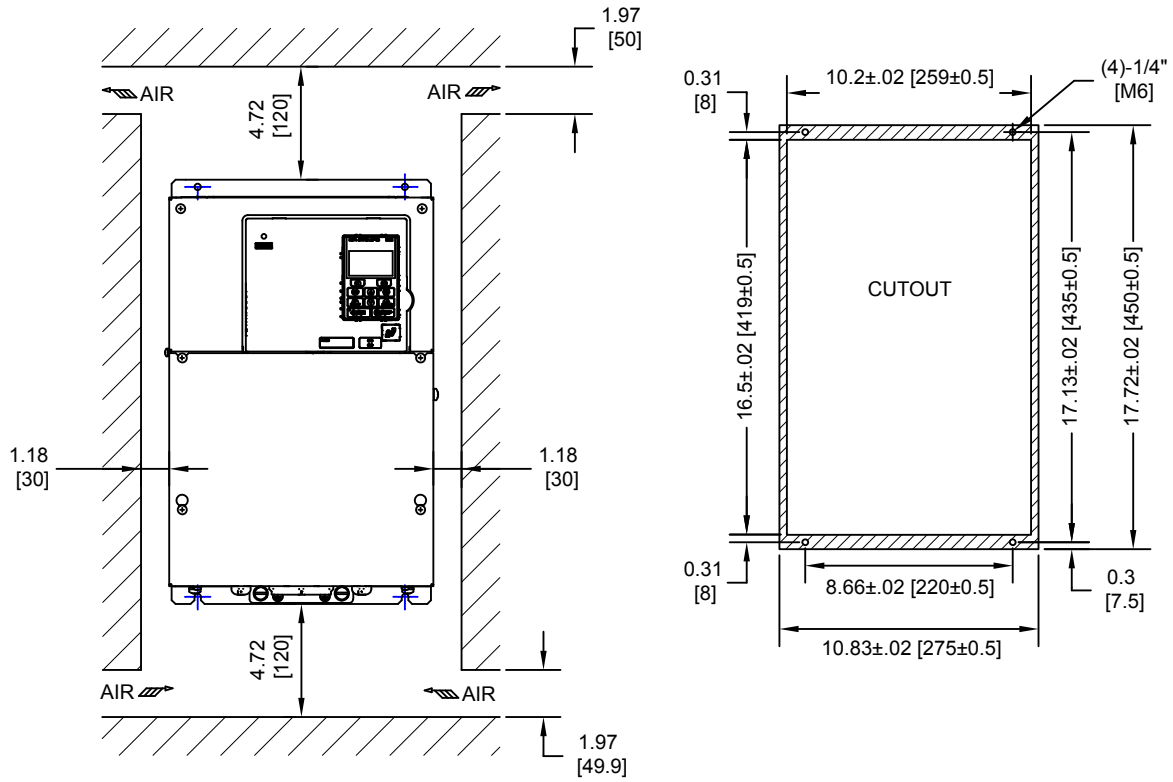

NOTE:
 EXPOSED HEATSINK DEPTH
 D=3.94" MINUS PANEL THICKNESS

Unit: in. [mm]

Figure 47 Non-Flange Type Model 4T0072A Clearances and Panel Cutout Dimensions

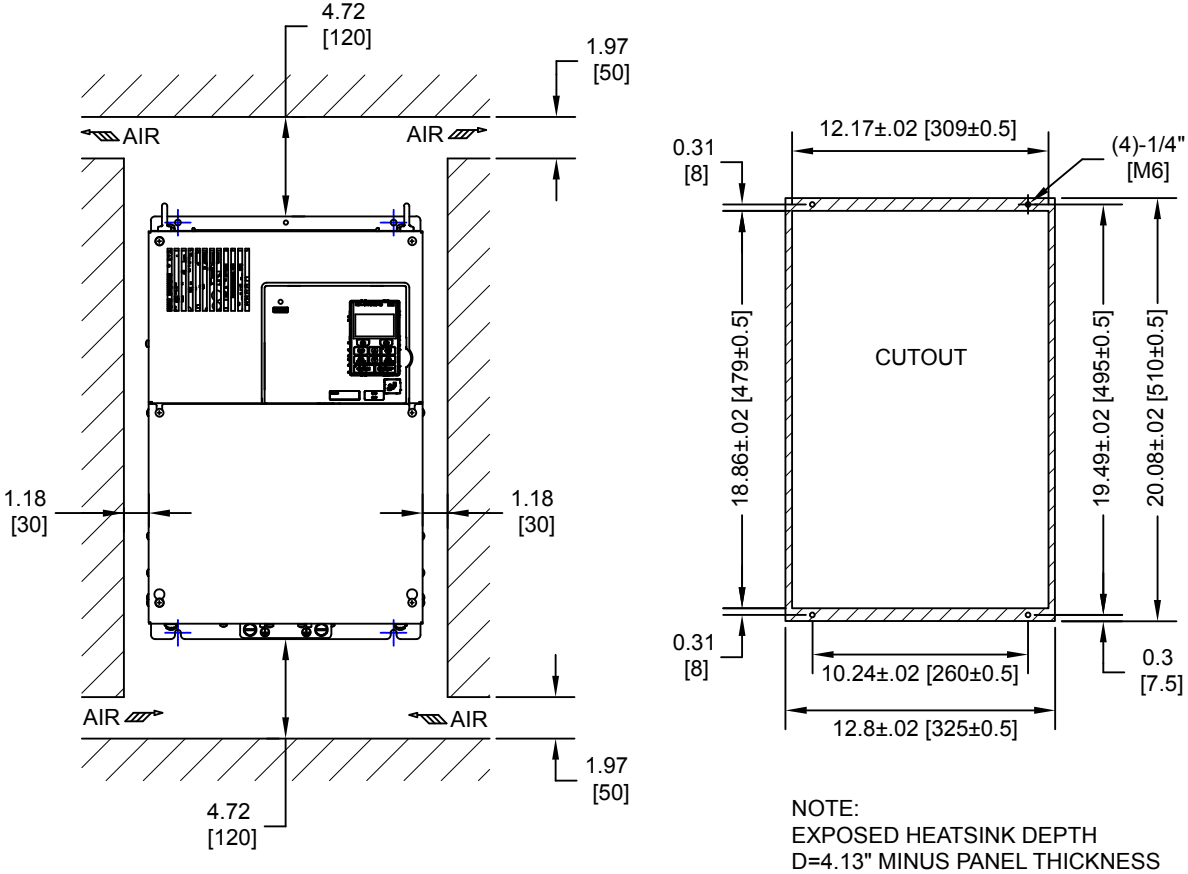

Unit: in. [mm]

Figure 48 Non-Flange Type Models 4T0088A and 4T0103A Clearances and Panel Cutout Dimensions

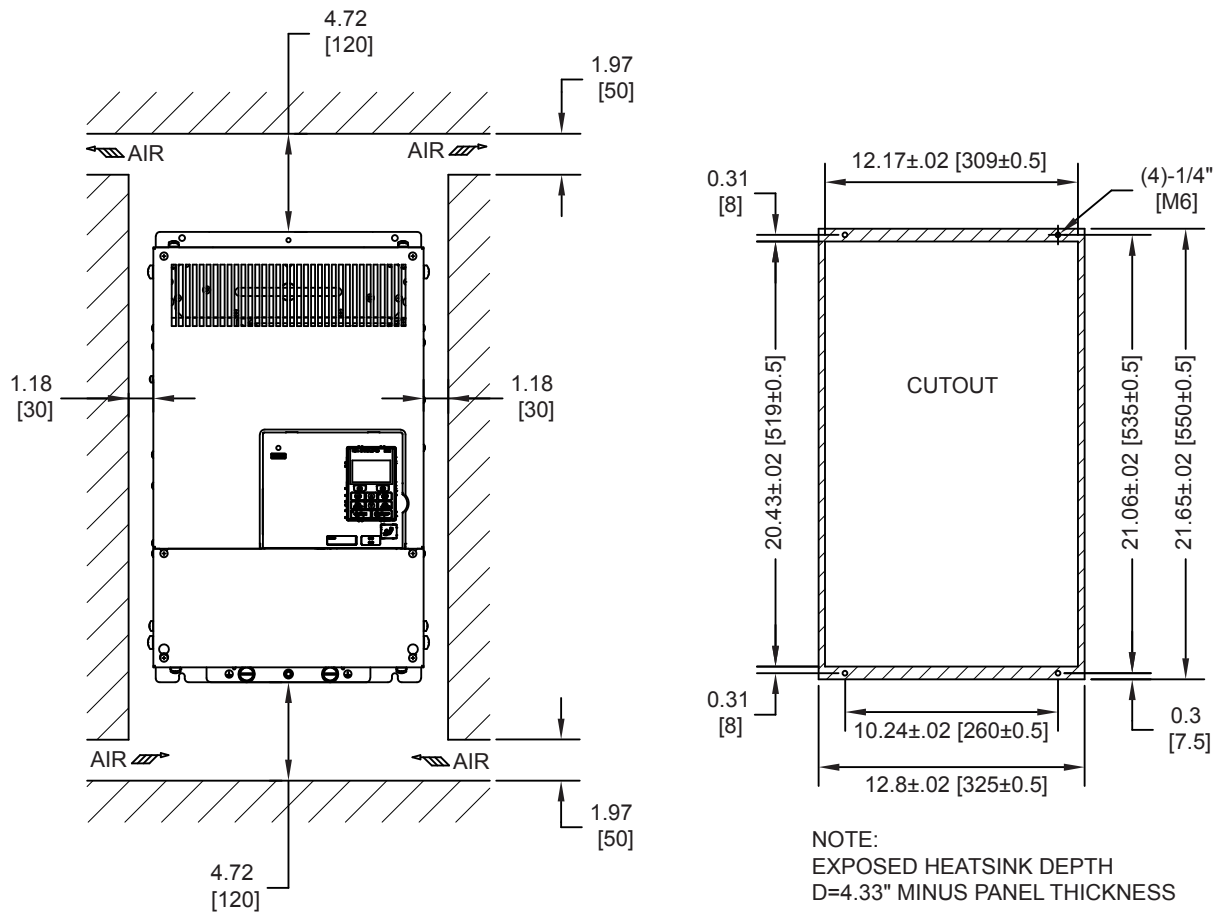

Unit: in. [mm]

Figure 49 Non-Flange Type Models 4T0139A and 4T0165A Clearances and Panel Cutout Dimensions

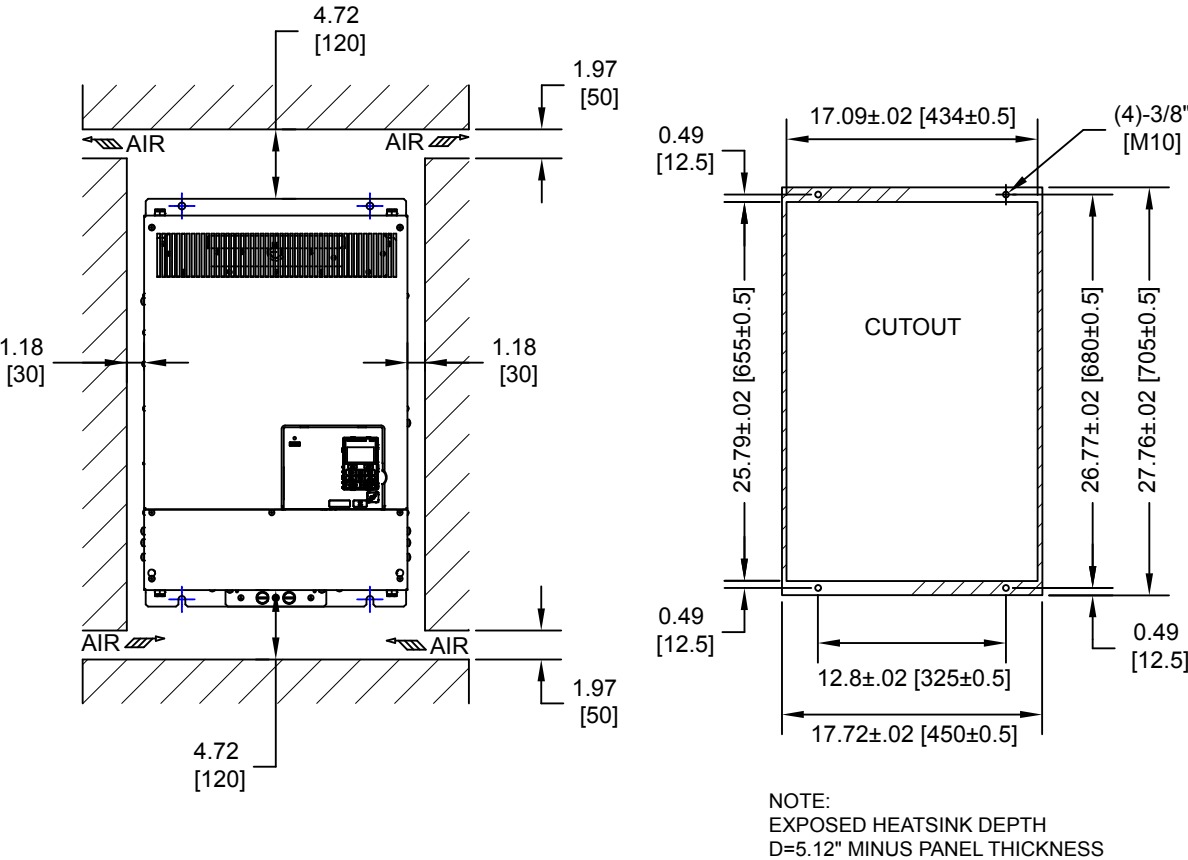

Unit: in. [mm]

Figure 50 Flange Type Model 4T0208A Clearances and Panel Cutout Dimensions

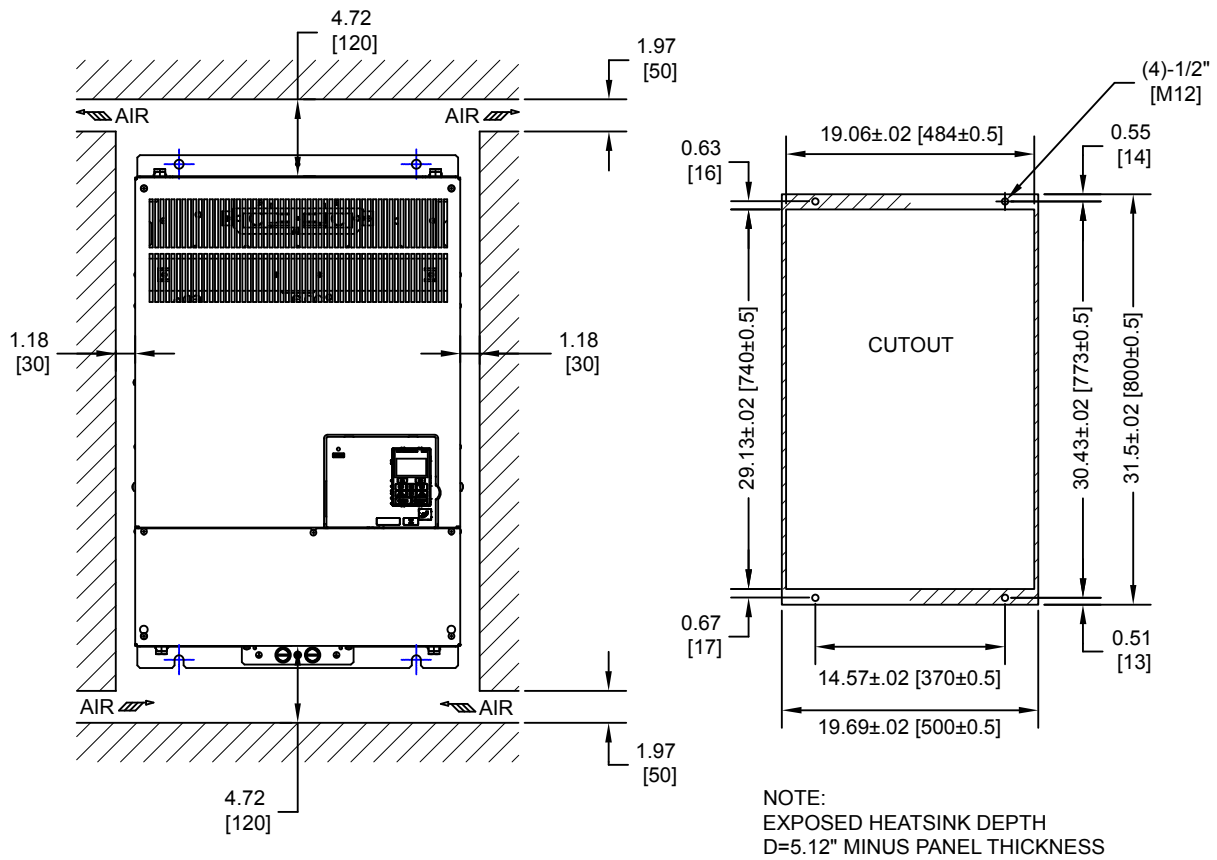

Unit: in. [mm]

Figure 51 Non-Flange Type Models 4T0250A to 4T0362A Clearances and Panel Cutout Dimensions

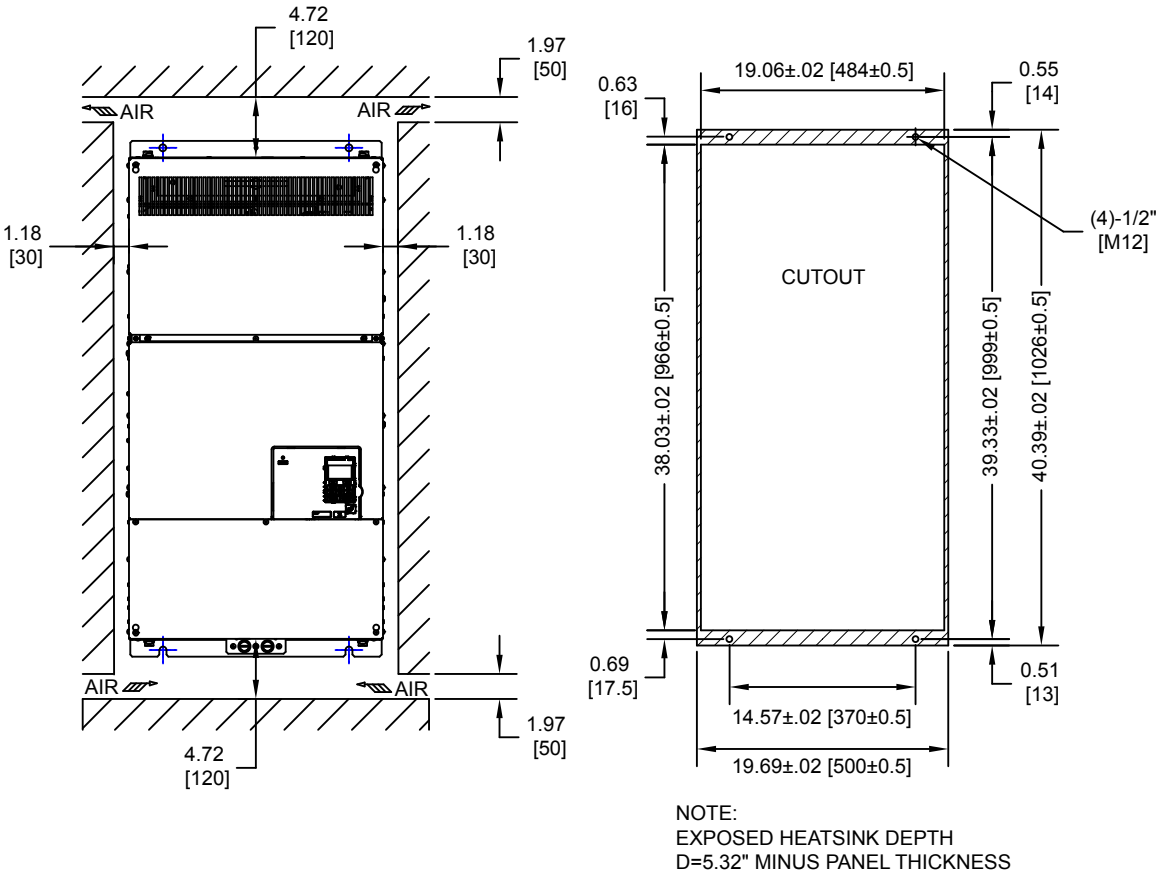

Unit: in. [mm]

Figure 52 Non-Flange Type Model 4T0414A Clearances and Panel Cutout Dimensions

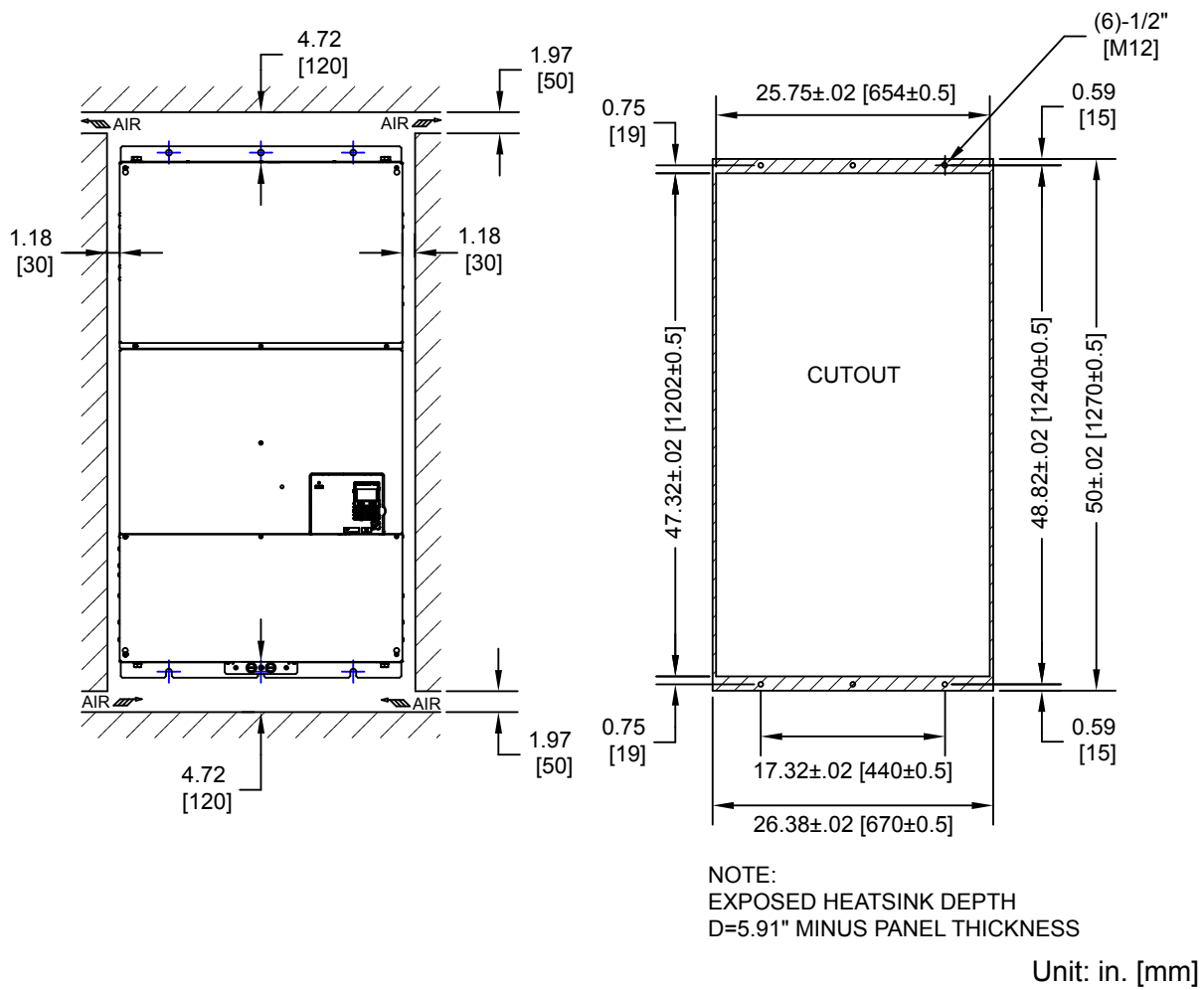

Figure 53 Non-Flange Type Models 4T0515A and 4T0675A Clearances and Panel Cutout Dimensions

9 Parameter Table

This parameter table shows the most important parameters. Default settings are in **bold type**. Refer to the drive Technical Manual for a complete list of parameters.

No.	Name	Description	No.	Name	Description
A1-02	Control Method Selection	0: V/f Control 1: V/f Control with PG 2: Open Loop Vector Control 3: Closed Loop Vector Control 5: Open Loop Vector Control for PM 6: Advanced Open Loop Vector Control for PM 7: Closed Loop Vector Control for PM	C6-02	Carrier Frequency Selection	1: 4.0 kHz 2: 6.0 kHz 3: 8.0 kHz 4: 10.0 kHz F: User-defined (determined by C6-03 to C6-05) Default setting value is determined by A1-02, Control Method Selection, C6-01, Drive Duty Selection, and o2-04, Drive Model Selection.
A1-03	Initialize Parameters	0: No initialization 1110: User Initialize (parameter values must be stored using parameter o2-03) 2220: 2-Wire initialization 3330: 3-Wire initialization 5550: oPE04 error reset	d1-01 to d1-16	Frequency Reference 1 to 16	Sets the frequency reference for the drive. Setting units are determined by parameter o1-03.
A1-06	Application Preset	0: General-purpose 1: Water supply pump 2: Conveyor 3: Exhaust fan 4: HVAC fan 5: Air compressor	d1-17	Jog Frequency Reference	Sets the Jog frequency reference. Setting units are determined by parameter o1-03.
b1-01	Frequency Reference Selection 1	0: Digital operator 1: Analog input terminals 2: MEMOBUS/Modbus communications 3: Option PCB 4: Pulse train input (terminal RP)	d2-01	Frequency Reference Upper Limit	Sets the frequency reference upper limit as a percentage of the maximum output frequency.
b1-02	Run Command Selection 1	0: Digital operator 1: Digital input terminals 2: MEMOBUS/Modbus communications 3: Option PCB	d2-02	Frequency Reference Lower Limit	Sets the frequency reference lower limit as a percentage of the maximum output frequency.
b1-03	Stopping Method Selection	0: Ramp to stop 1: Coast to stop 2: DC Injection Braking to stop 3: Coast with timer	E1-03	V/f Pattern Selection	0: 50 Hz, Constant torque 1 1: 60 Hz, Constant torque 2 2: 60 Hz, Constant torque 3 (50 Hz base) 3: 72 Hz, Constant torque 4 (60 Hz base) 4: 50 Hz, Variable torque 1 5: 50 Hz, Variable torque 2 6: 60 Hz, Variable torque 1 7: 60 Hz, Variable torque 2 8: 50 Hz, High starting torque 1 9: 50 Hz, High starting torque 2 A: 60 Hz, High starting torque 3 B: 60 Hz, High starting torque 4 C: 90 Hz (60 Hz base) D: 120 Hz (60 Hz base) E: 180 Hz (60 Hz base) F: Custom V/f, E1-04 through E1-13 settings define the V/f pattern
b1-04	Reverse Operation Selection	0: Reverse enabled. 1: Reverse disabled.	E1-04	Maximum Output Frequency	Parameters E1-04 and E1-06 to E1-13 can only be changed when E1-03 is set to F.
C1-01	Acceleration Time 1	Sets the time to accelerate from 0 to maximum frequency.	E1-05	Maximum Voltage	To set linear V/f characteristics, set the same values for E1-07 and E1-09.
C1-02	Deceleration Time 1	Sets the time to decelerate from maximum frequency to 0.	E1-06	Base Frequency	In this case, the setting for E1-08 will be disregarded. Ensure that the five frequencies are set according to the following rules to prevent triggering an oPE10 fault:
C2-01	S-Curve Characteristic at Accel Start	S-curve at acceleration start.	E1-07	Middle Output Frequency	$E1-09 \leq E1-07 < E1-06 \leq E1-11 \leq E1-04$
C2-02	S-Curve Characteristic at Accel End	S-curve at acceleration end.	E1-08	Middle Output Frequency Voltage	Setting E1-11 to 0 disables both E1-11 and E1-12 and the above conditions do not apply.
C2-03	S-Curve Characteristic at Decel Start	S-curve at deceleration start.	E1-09	Minimum Output Frequency	
C2-04	S-Curve Characteristic at Decel End	S-curve at deceleration end.	E1-10	Minimum Output Frequency Voltage	
C6-01	Drive Duty Selection	0: Heavy Duty (HD) Overload capability: 150% of drive rated Heavy Duty current for 60 s Default Carrier Frequency: 2 kHz 1: Normal Duty (ND) Overload capability: 120% of drive rated Normal Duty current for 60 s Default Carrier Frequency: 2 kHz Swing PWM	E1-11	Middle Output Frequency 2	
			E1-12	Middle Output Frequency Voltage 2	
			E1-13	Base Voltage	
			E2-01	Motor Rated Current	Sets the motor nameplate full load current in amps. Automatically set during Auto-Tuning.

9 Parameter Table

No.	Name	Description
H1-01 to H1-08	Multi-Function Digital Input Terminal S1 to S8 Function Selection	Selects the function of terminals S1 to S8.
H2-01	Multi-Function Contact Output (terminal M1-M2)	Sets the function for the relay output M1-M2.
H2-02	Multi-Function Contact Output 2 (terminal M3-M4)	Sets the function for the relay output M3-M4.
H2-03	Terminal M5-M6 function selection (relay)	Sets the function for the relay output M5-M6
H2-06	Power Consumption Output Unit Selection	0: 0.1 kWh units 1: 1 kWh units 2: 10 kWh units 3: 100 kWh units 4: 1000 kWh units
H2-07	MEMOBUS Register 1 Address Select	Sets the addresses of the MEMOBUS/Modbus registers from which data will be sent to contact outputs 62 and 162.
H2-08	MEMOBUS Register 1 Bit Select	Sets the bits for the MEMOBUS/Modbus registers from which data will be sent to contact outputs 62 and 162.
H2-09	MEMOBUS Register 2 Address Select	Sets the addresses of the MEMOBUS/Modbus registers from which data will be sent to contact outputs 63 and 163.
H2-10	MEMOBUS Register 2 Bit Select	Sets the bits for the MEMOBUS/Modbus registers from which data will be sent to contact outputs 63 and 163.
H3-01	Terminal A1 Signal Level Selection	0: 0 to 10 V 1: -10 to 10 V
H3-02	Terminal A1 Function Selection	Sets the function of terminal A1.
H3-03	Terminal A1 Gain Setting	Sets the level of the input value selected in H3-02 when 10 V is input at terminal A1.
H3-04	Terminal A1 Bias Setting	Sets the level of the input value selected in H3-02 when 0 V is input at terminal A1.
H3-05	Terminal A3 Signal Level Selection	0: 0 to 10 V 1: -10 to 10 V
H3-06	Terminal A3 Function Selection	Sets the function of terminal A3.
H3-07	Terminal A3 Gain Setting	Sets the level of the input value selected in H3-06 when 10 V is input at terminal A3.
H3-08	Terminal A3 Bias Setting	Sets the level of the input value selected in H3-06 when 0 V is input at terminal A3.
H3-09	Terminal A2 Signal Level Selection	0: 0 to 10 V 1: -10 to 10 V 2: 4 to 20 mA 3: 0 to 20 mA Note: Use DIP switch S1 to set input terminal A2 for a current or a voltage input signal.
H3-10	Terminal A2 Function Selection	Sets the function of terminal A2.
H3-11	Terminal A2 Gain Setting	Sets the level of the input value selected in H3-10 when 10 V (20 mA) is input at terminal A2.
H3-12	Terminal A2 Bias Setting	Sets the level of the input value selected in H3-10 when 0 V (0 or 4 mA) is input at terminal A2.
H3-13	Analog Input Filter Time Constant	Sets a primary delay filter time constant for terminals A1, A2, and A3. Used for noise filtering.

No.	Name	Description
H3-14	Analog Input Terminal Enable Selection	1: Terminal A1 only 2: Terminal A2 only 3: Terminals A1 and A2 only 4: Terminal A3 only 5: Terminals A1 and A3 6: Terminals A2 and A3 7: All terminals enabled
H3-16	Terminal A1 Offset	Adds an offset when the analog signal to terminal A1 is at 0 V.
H3-17	Terminal A2 Offset	Adds an offset when the analog signal to terminal A2 is at 0 V.
H3-18	Terminal A3 Offset	Adds an offset when the analog signal to terminal A3 is at 0 V.
H4-01	Multi-Function Analog Output Terminal FM Monitor Selection	Selects the data to be output through multi-function analog output terminal FM. Set the desired monitor parameter to the digits available in U□-□□. For example, enter "103" for U1-03.
H4-02	Multi-Function Analog Output Terminal FM Gain	Sets the signal level at terminal FM that is equal to 100% of the selected monitor value.
H4-03	Multi-Function Analog Output Terminal FM Bias	Sets the signal level at terminal FM that is equal to 0% of the selected monitor value.
H4-04	Multi-Function Analog Output Terminal AM Monitor Selection	Selects the data to be output through multi-function analog output terminal AM. Set the desired monitor parameter to the digits available in U□-□□. For example, enter "103" for U1-03.
H4-05	Multi-Function Analog Output Terminal AM Gain	Sets the signal level at terminal AM that is equal to 100% of the selected monitor value.
H4-06	Multi-Function Analog Output Terminal AM Bias	Sets the signal level at terminal AM that is equal to 0% of the selected monitor value.
H4-07	Multi-Function Analog Output Terminal FM Signal Level Selection	0: 0 to 10 V 1: -10 to 10 V 2: 4 to 20mA
H4-08	Multi-Function Analog Output Terminal AM Signal Level Selection	0: 0 to 10 V 1: -10 to 10 V 2: 4 to 20 mA
H5-01	Drive Node Address	Selects drive station node number (address) for MEMOBUS/Modbus terminals R+, R-, S+, S-. Cycle power for the setting to take effect.
H5-02	Communication Speed Selection	0: 1200 bps 1: 2400 bps 2: 4800 bps 3: 9600 bps 4: 19200 bps 5: 38400 bps 6: 57600 bps 7: 76800 bps 8: 115200 bps Cycle power for the setting to take effect.
H5-03	Communication Parity Selection	0: No parity 1: Even parity 2: Odd parity Cycle power for the setting to take effect.
H5-04	Stopping Method After Communication Error (CE)	0: Ramp to stop 1: Coast to stop 2: Fast Stop 3: Alarm only
H5-05	Communication Fault Detection Selection	0: Disabled 1: Enabled. If communication is lost for more than two seconds, a CE fault will occur.
H5-06	Drive Transmit Wait Time	Set the wait time between receiving and sending data.

No.	Name	Description
H5-07	RTS Control Selection	0: Disabled. RTS is always on. 1: Enabled. RTS turns on only when sending.
H5-09	Communication Fault Detection Time	Sets the time required to detect a communications error.
H5-10	Unit Selection for MEMOBUS/Modbus Register 0025H	0: 0.1 V units 1: 1 V units
H5-11	Communications ENTER Function Selection	0: Drive requires an Enter command before accepting any changes to parameter settings. 1: Parameter changes are activated immediately without the Enter command.
H5-12	Run Command Method Selection	0: FWD/Stop, REV/Stop 1: Run/Stop, FWD/REV
H6-01	Pulse Train Input Terminal RP Function Selection	0: Frequency reference 1: PID feedback value 2: PID setpoint value 3: V/f Control with Simple PG feedback (possible only when using motor 1 in V/f Control)
H6-02	Pulse Train Input Scaling	Sets the terminal RP input signal frequency that is equal to 100% of the value selected in H6-01.
H6-03	Pulse Train Input Gain	Sets the level of the value selected in H6-01 when a frequency with the value set in H6-02 is input.
H6-04	Pulse Train Input Bias	Sets the level of the value selected in H6-01 when 0 Hz is input.
H6-05	Pulse Train Input Filter Time	Sets the pulse train input filter time constant.
H6-06	Pulse Train Monitor Selection	Select the pulse train monitor output function (value of the □-□□ part of U□-□□). For example, enter “501” for U5-01.
H6-07	Pulse Train Monitor Scaling	Sets the terminal MP output signal frequency when the monitor value is 100%. For example, to have the pulse train monitor output equal the output frequency, set H6-06 to 102 and H6-07 to 0.
H6-08	Pulse Train Input Minimum Frequency	Sets the minimum frequency for the pulse train input to be detected. Enabled when H6-01 = 0, 1, or 2.
L1-01	Motor Overload Protection Selection	0: Disabled 1: General purpose motor (standard fan cooled) 2: Drive dedicated motor with a speed range of 1:10 3: Vector motor with a speed range of 1:100 4: PM motor with variable torque 5: PM motor with constant torque control 6: General purpose motor (50 Hz) Default setting is determined by parameter A1-02, Control Method Selection.
L1-02	Motor Overload Protection Time	Sets the motor thermal overload protection (oL1) time.
L2-01	Momentary Power Loss Operation Selection	0: Disabled. Drive trips on Uv1 fault when power is lost. 1: Recover within the time set in L2-02. Uv1 will be detected if power loss is longer than L2-02. 2: Recover as long as CPU has power. Uv1 is not detected. 3: KEB deceleration for the time set to L2-02. 4: KEB deceleration as long as CPU has power. 5: KEB deceleration to stop.

No.	Name	Description
L3-04	Stall Prevention Selection during Deceleration	0: Disabled. Deceleration at the active deceleration rate. An ov fault may occur. 1: General purpose. Deceleration is paused when the DC bus voltage exceeds the Stall Prevention level. 2: Intelligent. Decelerate as fast as possible while avoiding ov faults. 3: Stall Prevention with braking resistor. Stall Prevention during deceleration is enabled in coordination with dynamic braking. 4: Overexcitation Deceleration. Decelerates while increasing the motor flux. 5: Overexcitation Deceleration 2. Adjust the deceleration rate according to the DC voltage.
L5-01	Number of Auto Restart Attempts	Sets the number of times the drive may attempt to restart after the following faults occur: GF, LF, oC, oH1, oL1, oL3, oL4, ov, Sto, Uv1.
L6-01	Torque Detection Selection 1	0: Disabled 1: oL3 detection only active during speed agree, operation continues after detection 2: oL3 detection always active during run, operation continues after detection 3: oL3 detection only active during speed agree, output shuts down on an oL3 fault 4: oL3 detection always active during run, output shuts down on an oL3 fault 5: UL3 detection only active during speed agree, operation continues after detection 6: UL3 detection always active during run, operation continues after detection 7: UL3 detection only active during speed agree, output shuts down on a UL3 fault 8: UL3 detection always active during run, output shuts down on a UL3 fault
L6-02	Torque Detection Level 1	Sets the overtorque and undertorque detection level.
L6-03	Torque Detection Time 1	Sets the time an overtorque or undertorque condition must exist to trigger torque detection 1.
L8-01	Internal Dynamic Braking Resistor Protection Selection (ERF type)	0: Resistor overheat protection disabled 1: Resistor overheat protection enabled
L8-02	Overheat Alarm Level	An overheat alarm occurs when heatsink temperature exceeds the L8-02 level.
L8-03 (04AF)	Overheat Pre-Alarm Operation Selection	0: Ramp to stop. A fault is triggered. 1: Coast to stop. A fault is triggered. 2: Fast Stop. Decelerate to stop using the deceleration time in C1-09. A fault is triggered. 3: Continue operation. An alarm is triggered. 4: Continue operation at reduced speed as set in L8-19.
L8-05 (04B1)	Input Phase Loss Protection Selection	Selects the detection of input current phase loss, power supply voltage imbalance, or main circuit electrolytic capacitor deterioration. 0: Disabled 1: Enabled
L8-07 (04B3)	Output Phase Loss Protection Selection	0: Disabled 1: Enabled (triggered by a single phase loss) 2: Enabled (triggered when two phases are lost)
L8-09 (04B5)	Output Ground Fault Detection Selection	0: Disabled 1: Enabled Default setting is determined by parameters C6-01, Drive Duty Selection, and o2-04, Drive Model Selection.

9 Parameter Table

No.	Name	Description	No.	Name	Description
L8-10 (04B6)	Heatsink Cooling Fan Operation Selection	0: Run with timer (Fan operates only during run and for L8-11 seconds after stop.) 1: Run always (Cooling fan operates whenever the drive is powered up.)	L8-40 (04F1)	Carrier Frequency Reduction Off Delay Time	Sets the time that the drive continues running with reduced carrier frequency after the carrier reduction condition is gone. Setting 0.00 s disables the carrier frequency reduction time.
L8-11 (04B7)	Heatsink Cooling Fan Off Delay Time	Sets a delay time to shut off the cooling fan after the Run command is removed when L8-10 = 0.	L8-41 (04F2)	High Current Alarm Selection	0: Disabled 1: Enabled. An alarm is triggered at output currents above 150% of drive rated current.
L8-12 (04B8)	Ambient Temperature Setting	Enter the ambient temperature. This value adjusts the oL2 detection level.	L8-55 (045F)	Internal Braking Transistor Protection	0: Disabled. Disable when using a regen converter or optional braking unit. 1: Protection enabled.
L8-15 (04BB)	oL2 Characteristics Selection at Low Speeds	0: No oL2 level reduction below 6 Hz. 1: oL2 level is reduced linearly below 6 Hz. It is halved at 0 Hz.	L8-78 (02CC)	Power Unit Output Phase Loss Protection	Enables motor protection in the event of output phase loss. 0: Disabled 1: Enabled
L8-18 (04BE)	Software Current Limit Selection	0: Disabled 1: Enabled	L8-93 (073C)	LSo Detection Time at Low Speed	Sets the amount of time until baseblock is executed after detecting pull-out at low speed.
L8-19 (04BF)	Frequency Reduction Rate during Overheat Pre-Alarm	Specifies the frequency reference reduction gain at overheat pre-alarm when L8-03 = 4.	L8-94 (073D)	LSo Detection Level at Low Speed	Determines the detection level of pull-out at low speed.
L8-27 (04DD)	Overcurrent Detection Gain	Sets the gain for overcurrent detection as a percentage of the motor rated current. Overcurrent is detected using the lower value between the overcurrent level of the drive or the value set to L8-27.	L8-95 (073F)	Average LSo Frequency at Low Speed	Sets the average number of times pull-out can occur at low speed.
L8-29 (04DF)	Current Unbalance Detection (LF2)	0: Disabled 1: Enabled (current and voltage detection) 2: Enabled (current detection) 3: Enabled (voltage detection)	o1-03	Digital Operator Display Selection	0: 0.01 Hz 1: 0.01% (100% = E1-04) 2: r/min (calculated using the number of motor poles setting in E2-04, E4-04, or E5-04) 3: User-selected units (set by o1-10 and o1-11) Default setting is determined by parameter A1-02, Control Method Selection.
L8-32 (04E2)	Cooling Fan Failure Selection	Determines drive response when a fault occurs with the internal cooling fan. 0: Ramp to stop 1: Coast to stop 2: Fast stop (Decelerate to stop using the deceleration time set to C1-09) 3: Alarm only ("FAn" will flash) 4: Continue operation at reduced speed as set to L8-19.	T1-01	Auto-Tuning Mode Selection	0: Rotational Auto-Tuning 1: Stationary Auto-Tuning 1 2: Stationary Auto-Tuning for Line-to-Line Resistance 3: Rotational Auto-Tuning for V/f Control (necessary for Energy Savings and Speed Estimation Speed Search) 4: Stationary Auto-Tuning 2 5: Stationary Auto-Tuning 3 8: Inertia Tuning (perform Rotational Auto-Tuning prior to Inertia Tuning) 9: ASR Gain Tuning (perform Rotational Auto-Tuning prior to ASR Gain Auto-Tuning)
L8-35 (04EC)	Installation Method Selection	0: IP00/Open-Chassis enclosure 1: Side-by-Side mounting 2: IP20/NEMA Type 1 enclosure 3: Finless model drive or external heatsink installation Set this parameter to 3 for all 6-Phase/12-Pulse Flange and Non-Flange models.			
L8-38 (04EF)	Carrier Frequency Reduction	0: Disabled 1: Enabled below 6 Hz 2: Enabled for the entire speed range Default setting is determined by parameters A1-02, Control Method Selection, and o2-04, Drive Model Selection.			

10 Standards Compliance

◆ European Standards



Figure 54 CE Mark

The CE mark indicates compliance with European safety and environmental regulations. It is required for engaging in business and commerce in Europe.

European standards include the Machinery Directive for machine manufacturers, the Low Voltage Directive for electronics manufacturers, and the EMC guidelines for controlling noise.

This drive displays the CE mark based on the EMC guidelines and the Low Voltage Directive.

- **Low Voltage Directive:** 2006/95/EC
- **EMC Guidelines:** 2004/108/EC

Devices used in combination with this drive must also be CE certified and display the CE mark. When using drives displaying the CE mark in combination with other devices, it is ultimately the responsibility of the user to ensure compliance with CE standards. After setting up the device, verify that conditions meet European standards.

◆ CE Low Voltage Directive Compliance

This drive has been tested according to European standard IEC/EN 61800-5-1, and it fully complies with the Low Voltage Directive.

To comply with the Low Voltage Directive, be sure to meet the following conditions when combining this drive with other devices:

■ Area of Use

Do not use drives in areas with pollution higher than degree 2 and overvoltage category 3 in accordance with IEC/EN 664.

■ Grounding

The drive is designed to be used in T-N (grounded neutral point) networks. If installing the drive in other types of grounded systems, contact your Yaskawa representative for instructions.

■ Guarding Against Harmful Materials

When installing IP00/Open Type enclosure drives, use an enclosure that prevents foreign material from entering the drive from above or below.

◆ EMC Guidelines Compliance

This drive is tested according to European standards IEC/EN 61800-3: 2004.

■ EMC Filter Installation

The following conditions must be met to ensure continued compliance with guidelines. *Refer to EMC Filters on page 84* for EMC filter selection.

Installation Method

Verify the following installation conditions to ensure that other devices and machinery used in combination with this drive also comply with EMC guidelines.

1. Install an EMC noise filter to the input side specified by Yaskawa for compliance with European standards.
2. Place the drive and EMC noise filter in the same enclosure.
3. Use braided shield cable for the drive and motor wiring, or run the wiring through a metal conduit.
4. Keep wiring as short as possible. Ground the shield on both the drive side and the motor side.

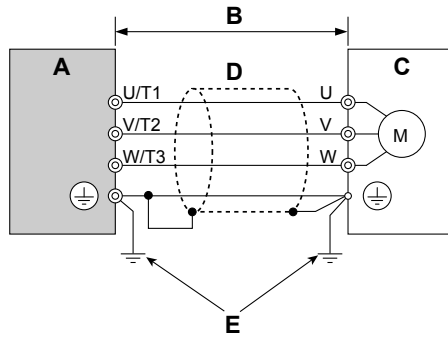

- A – Drive
- B – 10 m max cable length between drive and motor
- C – Motor
- D – Metal conduit
- E – Ground wire should be as short as possible.

Figure 55 Installation Method

5. Make sure the protective earthing conductor complies with technical standards and local safety regulations.

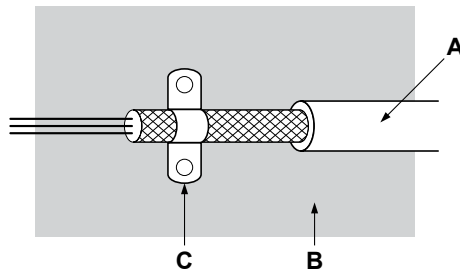

- A – Braided shield cable
- B – Metal panel
- C – Cable clamp (conductive)

Figure 56 Ground Area

6. Connect a DC link choke to minimize harmonic distortion.

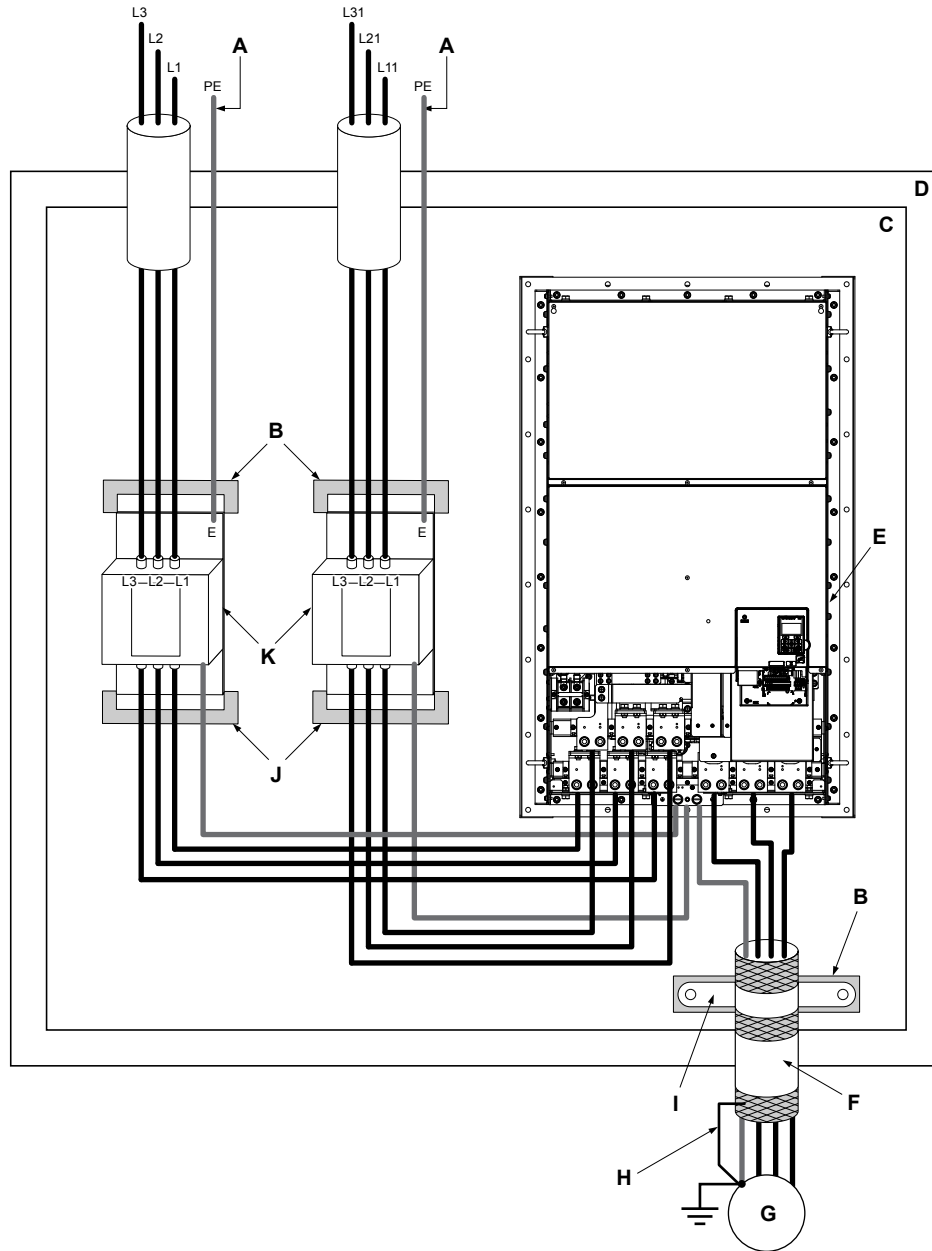

- A** – Make sure the ground wire is grounded
- B** – Grounding surface (remove any paint or sealant)
- C** – Metal plate
- D** – Enclosure panel
- E** – Drive
- F** – Motor cable (braided shield cable, max. 10 m)
- G** – Motor
- H** – Cable shield ground
- I** – Cable clamp
- J** – Ground plate (scrape off any visible paint)
- K** – EMC noise filter

Figure 57 EMC Filter and Drive Installation for CE Compliance

10 Standards Compliance

■ EMC Filters

Install the drive with the EMC filters listed in [Table 12](#) to comply with the IEC/EN 61800-3 requirements.

Table 12 IEC/EN 61800-3 Filters

Drive Model	Type	Rated Current (A)	Weight (lb)	Dimensions [W x D x H] (in)	Y x X (in)	Qty. per Unit
	Manufacturer: Schaffner					
4A0058□	FS5972-35-07	35	4.6	8.1 × 2.0 × 14.0	6.9 × 13.2	2
4A0072□	FS5972-60-07	60	8.8	9.3 × 2.6 × 16.1	8.1 × 15.4	2
4A0088□						
4A0103□						
4A0139□	FS5972-100-35	100	7.5	3.5 × 5.9 × 13.0	2.6 × 10.0	2
4A0165□						
4A0208□	FS5972-130-35	130	10.4	3.5 × 7.1 × 14.6	2.6 × 11.6	2
4A0250□						
4A0296□	FS5972-170-40	170	13.2	4.7 × 6.7 × 17.8	4.0 × 14.4	2
4A0362□	FS5972-250-37	250	25.8	5.1 × 9.5 × 24.0	3.5 × 19.6	2
4A0414□						
4A0515□	FS5972-410-99	410	23.1	10.2 × 4.5 × 15.2	9.3 × 4.7	2
4A0675□						

◆ UL Standards

The UL/cUL mark applies to products in the United States and Canada. It indicates that UL has performed product testing and evaluation, and determined that their stringent standards for product safety have been met. For a product to receive UL certification, all components inside that product must also receive UL certification.



Figure 58 UL/cUL Mark

This drive is tested in accordance with UL standard UL508C and complies with UL requirements. The conditions described below must be met to maintain compliance when using this drive in combination with other equipment:

■ Installation Area

Do not install the drive to an area greater than pollution degree 2 (UL standard).

■ Ambient Temperature

Flange Type Enclosure: -10 °C to +40 °C (14 °F to 104 °F)

Non-Flange Type Enclosure: -10 °C to +50 °C (14 °F to 122 °F)

■ Factory Recommended Branch Circuit Protection

Yaskawa recommends installing the following branch circuit protection on each of the 6 phases of the secondary circuit of a 6-Phase/12-Pulse transformer to maintain standards compliance. Semiconductor protective type fuses as listed in [Table 13](#) are preferred. Alternate branch circuit protection devices are listed in [Table 14](#). Refer to local codes for proper Branch Circuit Protection on the primary circuit of a 6-Phase/12-Pulse transformer.

NOTICE: If a fuse is blown or a Ground Fault Circuit Interrupter (GFCI) is tripped, check the wiring and the selection of peripheral devices to identify the cause. Contact Yaskawa before restarting the drive or the peripheral devices if the cause cannot be identified.

Table 13 Factory Recommended Drive Branch Circuit Protection

Drive Model	Bussmann Fuse Type	
	Model	Fuse Ampere Rating (A)
4T0058□	FWH-100B	100
4T0072□	FWH-150B	150
4T0088□	FWH-200B	200
4T0103□	FWH-200B	200
4T0139□	FWH-200B	200
4T0165□	FWH-200B	200
4T0208□	FWH-275A	275
4T0250□	FWH-275A	275
4T0296□	FWH-350A	350
4T0362□	FWH-350A	350
4T0414□	FWH-450A	450
4T0515□	FWH-500A	500
4T0675□	FWH-700A	700

■ Alternative Branch Circuit Protection

The alternative branch circuit protection is time delay fuses. The maximum time delay fuse is 175% of drive input current rating listed in [Table 14](#). This covers any Class J or T fuse.

Table 14 Alternative AC Drive Branch Circuit Protection

Drive Model	Nominal Output Power kW (HP)	Drive Input Amps/Phase <1>	Time Delay Fuse Class J or T Rating Amps Max.
4T0058□	30 (40)	27	45
4T0072□	37 (50)	33	50
4T0088□	45 (60)	39.5	60
4T0103□	55 (75)	48.5	80
4T0139□	75 (100)	65.5	110
4T0165□	90 (125)	78	125
4T0208□	110 (150)	95	150
4T0250□	132 (200)	114	175
4T0296□	160 (250)	137.5	225
4T0362□	185 (300)	158.5	275
4T0414□	220 (350)	188	300
4T0515□	250 (400)	213.5	350
4T0675□	355 (550)	301.5	500

<1> This amp rating is 1/2 rated current because the 3-Phase current is split between 6 input phases for the 6-Phase/12-Pulse drive. Use this amp rating to select input wiring size as recommended in [Table 5](#).

■ Main Circuit Terminal Wiring

Yaskawa recommends using closed-loop crimp terminals on all drive models. To maintain UL/cUL approval, UL Listed closed-loop crimp terminals are specially required when wiring the drive main circuit terminals. Use only the tools recommended by the terminal manufacturer for crimping. Refer to [Table 15](#) for closed-loop crimp terminal recommendations.

10 Standards Compliance

Closed-Loop Crimp Terminal Recommendations

Yaskawa recommends using closed-loop crimp terminals on all drive models. UL approval requires the use of UL Listed crimp terminals when wiring the drive main circuit terminals. Use only crimping tools as specified by the crimp terminal manufacturer. Yaskawa recommends crimp terminals made by JST and Tokyo DIP (or equivalent) for the insulation cap. **Table 15** matches the wire gauges and terminal screw sizes with Yaskawa-recommended crimp terminals, tools, and insulation caps. **Refer to Wire Gauge and Torque Specifications on page 23** for the wire gauge and screw size for your drive model. Place orders with a Yaskawa representative or the Yaskawa sales department.

The closed-loop crimp terminal sizes and values listed in **Table 15** are Yaskawa recommendations. Refer to local codes for proper selections.

Table 15 Closed-Loop Crimp Terminal Size

Wire Gauge	Terminal Screws	Crimp Terminal Model Number	Tool		Insulation Cap Model No.	Code
			Machine No.	Die Jaw		
14 AWG	M4	R2-4	YA-4	AD-900	TP-003	100-054-028
12 / 10 AWG	M4	R5.5-4	YA-4	AD-900	TP-005	100-054-029
	M5	R5.5-5	YA-4	AD-900	TP-005	100-054-030
	M6	R5.5-6	YA-4	AD-900	TP-005	100-068-029
	M8	R5.5-8	YA-4	AD-900	TP-005	100-068-030
8 AWG	M4	8-4	YA-4	AD-901	TP-008	100-054-031
	M5	R8-5	YA-4	AD-901	TP-008	100-054-032
	M8	R8-8	YA-4	AD-901	TP-008	100-061-111
6 AWG	M4	14-NK4	YA-4, YA-5	AD-902, AD-952	TP-014	100-054-033
	M5	R14-5	YA-4, YA-5	AD-902, AD-952	TP-014	100-054-034
	M6	R14-6	YA-4, YA-5	AD-902, AD-952	TP-014	100-051-261
	M8	R14-8	YA-4, YA-5	AD-902, AD-952	TP-014	100-054-035
	M10	R14-10	YA-4, YA-5	AD-902, AD-952	TP-014	100-061-112
4 AWG	M6	R22-6	YA-5	AD-953	TP-022	100-051-262
	M8	R22-8	YA-5	AD-953	TP-022	100-051-263
	M10	R22-10	YA-5	AD-953	TP-022	100-061-113
3 / 2 / 1 AWG	M6	38-S6	YA-5	AD-954	TP-038	100-068-031
	M8	R38-8	YA-5	AD-954	TP-038	100-051-264
	M10	R38-10	YA-5	AD-954	TP-038	100-061-114
1/0 AWG 1/0 AWG × 2P	M8	R60-8	YA-5 YF-1, YET-300-1	AD-955 TD-321, TD-311	TP-060	100-051-265
	M10	R60-10	YA-5 YF-1, YET-300-1	AD-955 TD-321, TD-311	TP-060	100-051-266
1 AWG × 2P 2 AWG × 2P	M10	38-L10	YA-5 YF-1, YET-150-1	AD-954 TD-224, TD-212	TP-038	100-051-556
2/0 AWG 2/0 AWG × 2P	M10	70-10	YF-1, YET-300-1	TD-323, TD-312	TP-080	100-054-036
3/0 AWG	M10	80-10	YF-1, YET-300-1	TD-323, TD-312	TP-080	100-051-267
3/0 AWG × 2P 3/0 AWG × 4P	M10	80-L10	YF-1, YET-150-1 YF-1, YET-300-1	TD-227, TD-214 TD-323, TD-312	TP-080	100-051-557
	M12	80-L12	YF-1, YET-150-1 YF-1, YET-300-1	TD-227, TD-214 TD-323, TD-312	TP-080	100-051-558
4/0 AWG	M8	100-8	YF-1, YET-150-1 YF-1, YET-300-1	TD-228, TD-214 TD-324, TD-312	TP-100	100-068-032
	M10	R100-10	YF-1, YET-150-1 YF-1, YET-300-1	TD-228, TD-214 TD-324, TD-312	TP-100	100-051-269
4/0 AWG × 2P 4/0 AWG × 4P	M10	100-L10	YF-1, YET-150-1 YF-1, YET-300-1	TD-228, TD-214 TD-324, TD-312	TP-100	100-051-559
	M12	100-L12	YF-1, YET-150-1 YF-1, YET-300-1	TD-228, TD-214 TD-324, TD-312	TP-100	100-051-560

Wire Gauge	Terminal Screws	Crimp Terminal Model Number	Tool		Insulation Cap Model No.	Code
			Machine No.	Die Jaw		
250 / 300 kcmil	M10	R150-10	YF-1, YET-150-1 YF-1, YET-300-1	TD-229, TD-215 TD-325, TD-313	TP-150	100-051-272
	M12	R150-12	YF-1, YET-150-1 YF-1, YET-300-1	TD-229, TD-215 TD-325, TD-313	TP-150	100-051-273
250 kcmil × 2P 250 kcmil × 4P 300 kcmil × 2P 300 kcmil × 4P	M10	150-L10	YF-1, YET-150-1 YF-1, YET-300-1	TD-229, TD-215 TD-325, TD-313	TP-150	100-051-561
	M12	150-L12	YF-1, YET-150-1 YF-1, YET-300-1	TD-229, TD-215 TD-325, TD-313	TP-150	100-051-562
350 kcmil	M10	180-10	YF-1, YET-300-1	TD-326, TD-313	TP-200	100-066-687
	M12	180-12	YF-1, YET-300-1	TD-326, TD-313	TP-200	100-066-689
400 kcmil	M10	200-10	YF-1, YET-300-1	TD-327, TD-314	TP-200	100-051-563
	M12	R200-12	YF-1, YET-300-1	TD-327, TD-314	TP-200	100-051-275
350 kcmil × 2P	M12	180-L12	YF-1, YET-300-1	TD-326, TD-313	TP-200	100-066-688
400 kcmil × 2P	M12	200-L12	YF-1, YET-300-1	TD-327, TD-314	TP-200	100-051-564
500 kcmil 600 / 650 kcmil 500 kcmil × 2P 600 kcmil × 2P	M10	325-10	YF-1, YET-300-1	TD-328, TD-315	TP-325	100-051-565
	M12	325-12	YF-1, YET-300-1	TD-328, TD-315	TP-325	100-051-277

- <1> Codes refer to a set of three crimp terminals and three insulation caps. Prepare input and output wiring using two sets for each connection.
 Example 1: Models with 300 kcmil for both input and output require one set for input terminals and one set for output terminals, so the user should order two sets of [100-051-272].
 Example 2: Models with 4/0 AWG × 2P for both input and output require two sets for input terminals and two sets for output terminals, so the user should order four sets of [100-051-560].

■ Low Voltage Wiring for Control Circuit Terminals

Wire low voltage wires with NEC Class 1 circuit conductors. Refer to national state or local codes for wiring. The external power supply shall be a UL listed Class 2 power supply source or equivalent only.

Table 16 Control Circuit Terminal Power Supply

Input / Output	Terminal Signal	Power Supply Specifications
Open Collector Outputs	P1, P2, PC, DM+, DM-	Requires class 2 power supply
Digital inputs	S1 to S8, SC, HC, H1, H2	Use the internal LVLC power supply of the drive. Use class 2 for external power supply.
Analog inputs / outputs	+V, -V, A1, A2, A3, AC, AM, FM	Use the internal LVLC power supply of the drive. Use class 2 for external power supply.

■ Drive Short Circuit Rating

The drive is suitable for use on a circuit capable of delivering not more than 100,000 RMS symmetrical Amperes, 480 Vac maximum (400 V Class), when protected by fuses as specified in *Factory Recommended Branch Circuit Protection* on page 85.

◆ Drive Motor Overload Protection

Set parameter E2-01 (motor rated current) to the appropriate value to enable motor overload protection. The internal motor overload protection is UL Listed and in accordance with the NEC and CEC.

■ E2-01: Motor Rated Current

Setting Range: Model-dependent

Default Setting: Model-dependent

Parameter E2-01 protects the motor when parameter L1-01 is not set to 0. The default for L1-01 is 1, which enables protection for standard induction motors.

If Auto-Tuning has been performed successfully, the motor data entered to T1-04 is automatically written to parameter E2-01. If Auto-Tuning has not been performed, manually enter the correct motor rated current to parameter E2-01.

■ L1-01: Motor Overload Protection Selection

The drive has an electronic overload protection function (oL1) based on time, output current, and output frequency that protects the motor from overheating. The electronic thermal overload function is UL-recognized, so it does not require an external thermal relay for single motor operation.

This parameter selects the motor overload curve used according to the type of motor applied.

Table 17 Overload Protection Settings

Setting	Description	
0	Disabled	Disabled the internal motor overload protection of the drive.
1	Standard fan-cooled motor (default)	Selects protection characteristics for a standard self-cooled motor with limited cooling capabilities when running below the rated speed. The motor overload detection level (oL1) is automatically reduced when running below the motor rated speed.
2	Drive duty motor with a speed range of 1:10	Selects protection characteristics for a motor with self-cooling capability within a speed range of 10:1. The motor overload detection level (oL1) is automatically reduced when running below 1/10 of the motor rated speed.
3	Vector motor with a speed range of 1:100	Selects protection characteristics for a motor capable of cooling itself at any speed including zero speed (externally cooled motor). The motor overload detection level (oL1) is constant over the entire speed range.
4	Permanent Magnet motor with variable torque	Selects protection characteristics for a variable torque PM motor. The motor overload detection level (oL1) is automatically reduced when running below the motor rated speed.
5	Permanent Magnet motor with constant torque	Selects protection characteristics for a constant torque PM motor. The motor overload detection level (oL1) is constant over the whole speed range.
6	Standard fan-cooled motor (50 Hz)	Selects protection characteristics for a standard self-cooled motor with limited cooling capabilities when running below the rated speed. The motor overload detection level (oL1) is automatically reduced when running below the motor rated speed.

When connecting the drive to more than one motor for simultaneous operation, disable the electronic overload protection (L1-01 = 0) and wire each motor with its own motor thermal overload relay.

Enable motor overload protection (L1-01 = 1 to 6) when connecting the drive to a single motor, unless another motor overload preventing device is installed. The drive electronic thermal overload function causes an oL1 fault, which shuts off the output of the drive and prevents additional overheating of the motor. The motor temperature is continually calculated while the drive is powered up.

■ L1-02: Motor Overload Protection Time

Setting Range: 0.1 to 5.0 min

Factory Default: 1.0 min

Parameter L1-02 determines how long the motor is allowed to operate before the oL1 fault occurs when the drive is running a hot motor at 60 Hz and at 150% of the full load amp rating (E2-01) of the motor. Adjusting the value of L1-02 can shift the set of oL1 curves up the y axis of the diagram below, but will not change the shape of the curves.

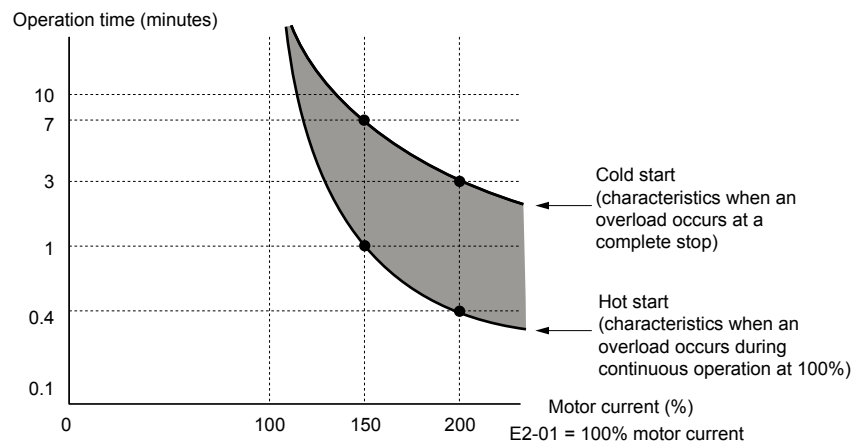

Figure 59 Motor Overload Protection Time

Revision History

The revision dates and the numbers of the revised manuals appear on the bottom of the back cover.

Example:

MANUAL NO. TOEP YAIA1U 02A

Published in USA April 2015 15-4

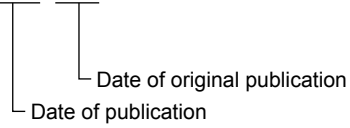

Date of Publication	Revision Number	Section	Revised Content
April 2015	-	-	First Edition. This manual supports drive software version PRG: 1020.

A1000 6-Phase/12-Pulse Input Flange Mount and Non-Flange Mount Installation Manual

YASKAWA AMERICA, INC.

2121, Norman Drive South, Waukegan, IL 60085, U.S.A.
Phone: 1-800-YASKAWA (927-5292) or 1-847-887-7000 Fax: 1-847-887-7310
<http://www.yaskawa.com>

DRIVE CENTER (INVERTER PLANT)

2-13-1, Nishimiyaichi, Yukuhashi, Fukuoka, 824-8511, Japan
Phone: 81-930-25-3844 Fax: 81-930-25-4369
<http://www.yaskawa.co.jp>

YASKAWA ELECTRIC CORPORATION

New Pier Takeshiba South Tower, 1-16-1, Kaigan, Minatoku, Tokyo, 105-6891, Japan
Phone: 81-3-5402-4502 Fax: 81-3-5402-4580
<http://www.yaskawa.co.jp>

YASKAWA ELÉTRICO DO BRASIL LTDA.

777, Avenida Piraporinha, Diadema, São Paulo, 09950-000, Brasil
Phone: 55-11-3585-1100 Fax: 55-11-3585-1187
<http://www.yaskawa.com.br>

YASKAWA EUROPE GmbH

185, Hauptstraße, Eschborn, 65760, Germany
Phone: 49-6196-569-300 Fax: 49-6196-569-398
<http://www.yaskawa.eu.com>

YASKAWA ELECTRIC KOREA CORPORATION

9F, Kyobo Securities Bldg., 26-4, Yeouido-dong, Yeongdeungpo-gu, Seoul, 150-737, Korea
Phone: 82-2-784-7844 Fax: 82-2-784-8495
<http://www.yaskawa.co.kr>

YASKAWA ELECTRIC (SINGAPORE) PTE. LTD.

151, Lorong Chuan, #04-02A, New Tech Park, 556741, Singapore
Phone: 65-6282-3003 Fax: 65-6289-3003
<http://www.yaskawa.com.sg>

YASKAWA ELECTRIC (THAILAND) CO., LTD.

252/125-126, 27th Floor, Muang Thai-Phatra Tower B, Rachadapisek Road, Huaykwang, Bangkok, 10310, Thailand
Phone: 66-2693-2200 Fax: 66-2693-4200
<http://www.yaskawa.co.th>

YASKAWA ELECTRIC (CHINA) CO., LTD.

22F, One Corporate Avenue, No.222, Hubin Road, Shanghai, 200021, China
Phone: 86-21-5385-2200 Fax: 86-21-5385-3299
<http://www.yaskawa.com.cn>

YASKAWA ELECTRIC (CHINA) CO., LTD. BEIJING OFFICE

Room 1011, Tower W3 Oriental Plaza, No. 1, East Chang An Ave.,
Dong Cheng District, Beijing, 100738, China
Phone: 86-10-8518-4086 Fax: 86-10-8518-4082

YASKAWA ELECTRIC TAIWAN CORPORATION

9F, 16, Nanking E. Rd., Sec. 3, Taipei, 104, Taiwan
Phone: 886-2-2502-5003 Fax: 886-2-2505-1280

YASKAWA INDIA PRIVATE LIMITED

#17/A, Electronics City, Hosur Road, Bangalore, 560 100 (Karnataka), India
Phone: 91-80-4244-1900 Fax: 91-80-4244-1901
<http://www.yaskawaindia.in>

YASKAWA

YASKAWA AMERICA, INC.

In the event that the end user of this product is to be the military and said product is to be employed in any weapons systems or the manufacture thereof, the export will fall under the relevant regulations as stipulated in the Foreign Exchange and Foreign Trade Regulations. Therefore, be sure to follow all procedures and submit all relevant documentation according to any and all rules, regulations and laws that may apply.

Specifications are subject to change without notice for ongoing product modifications and improvements.

© 2015 YASKAWA AMERICA, INC. All rights reserved.



TOEPYAIA1U02

MANUAL NO. TOEP YAIA1U 02A

Published in USA April 2015 15-4