

EXTERNAL DIMENSIONS:

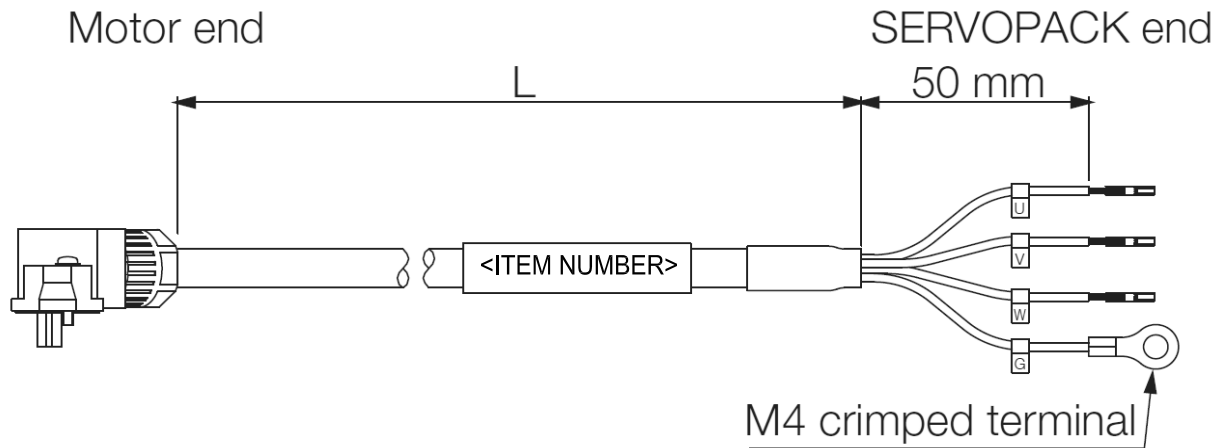

The recommended bend radius is 90mm or larger for moving parts of machines, such as robots.

The recommended bend radius is 15mm or larger for fixed installations.

MOTOR END CONNECTOR

Item	Description
Order Number	JZSP-C7M9-2-E
Manufacturer	J.S.T. Mfg. Co., Ltd.
User Instructions	JFA Connector J-2700
Components	Receptacle
	Contacts
Applicable Wire Sizes	Power terminals: AWG20 Holding brake terminals: AWG20 to AWG24
Applicable Cable Diameter	7 mm ±0.3 mm
Outer Diameter of Insulating Sheath	1.11 mm to 1.53 mm
Mounting Screws	M2 pan-head screws
Crimping Tool*	Hand Tool
	Applicator

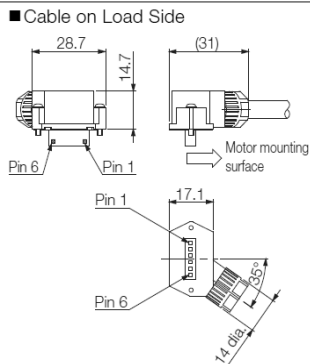

External Dimensions [mm]

* A Crimping Tool is required. Contact the connector manufacturer for details.

RAW CABLE

Item	Flexible Cable
Order Number*	JZSP-C7M29-□□-E (maximum length: 50 m)
Specifications	UL2517 (rated temperature:105°C) AWG20 × 4C, AWG22 × 2C
	Power lines: AWG20 (0.52 mm ²) Outer diameter of insulating sheath: 1.37 mm
	Holding brake lines: AWG22 (0.33 mm ²) Outer diameter of insulating sheath: 1.37 mm
Finished Diameter	7 mm ±0.3 mm
Internal Structure and Lead Colors	

* Replace the boxes (□□) in the order number with the cable length (05, 10, 15, 20, 30, 40, or 50).

WIRING SPECIFICATIONS

SERVOPACK Leads		Servomotor Connector	
Wire Color	Signal	Signal	Pin
Green/yellow	FG	FG	1
Blue	Phase W	Phase W	2
White	Phase V	Phase V	3
Red	Phase U	Phase U	4
		-	5
		-	6

ITEM NUMBER	L=Length
JZSP-C7M22F-03-E	3000
JZSP-C7M22F-05-E	5000
JZSP-C7M22F-10-E	10000
JZSP-C7M22F-15-E	15000
JZSP-C7M22F-20-E	20000
JZSP-C7M22F-30-E	30000
JZSP-C7M22F-40-E	40000
JZSP-C7M22F-50-E	50000

THIS DOCUMENT AND THE INFORMATION CONTAINED IN IT ARE PUBLIC AND CAN BE DISCLOSED WITHOUT EXPRESS WRITTEN CONSENT OF YASKAWA AMERICA INC. SPECIFICATIONS ARE SUBJECT TO CHANGE WITHOUT NOTICE FOR ONGOING PRODUCT MODIFICATIONS AND IMPROVEMENTS.		<h1>YASKAWA</h1> <p>TITLE:SGM7J/7A-02 to -06. 200W to 600W Servomotor Power Cable, No Brake, Toward Load, Flexible, Non-Shielded</p>							
ITEM #: JZSP-C7M22F-xx-E (xx = See Chart)									
SCALE: NTS	UNITS: mm	SHEET: 1/1	<table border="1"> <tr> <th>SIZE</th> <th>REVISION</th> <th>PAGE</th> </tr> <tr> <td>-</td> <td>0</td> <td>1 of 1</td> </tr> </table>	SIZE	REVISION	PAGE	-	0	1 of 1
SIZE	REVISION	PAGE							
-	0	1 of 1							
DRAWING #: CAD-JZSP-C7M22F-xx-E									

REV	DESCRIPTION	DATE	DRAWN BY
0	Initial Release	12/20/2018	E. SONDERMAN