

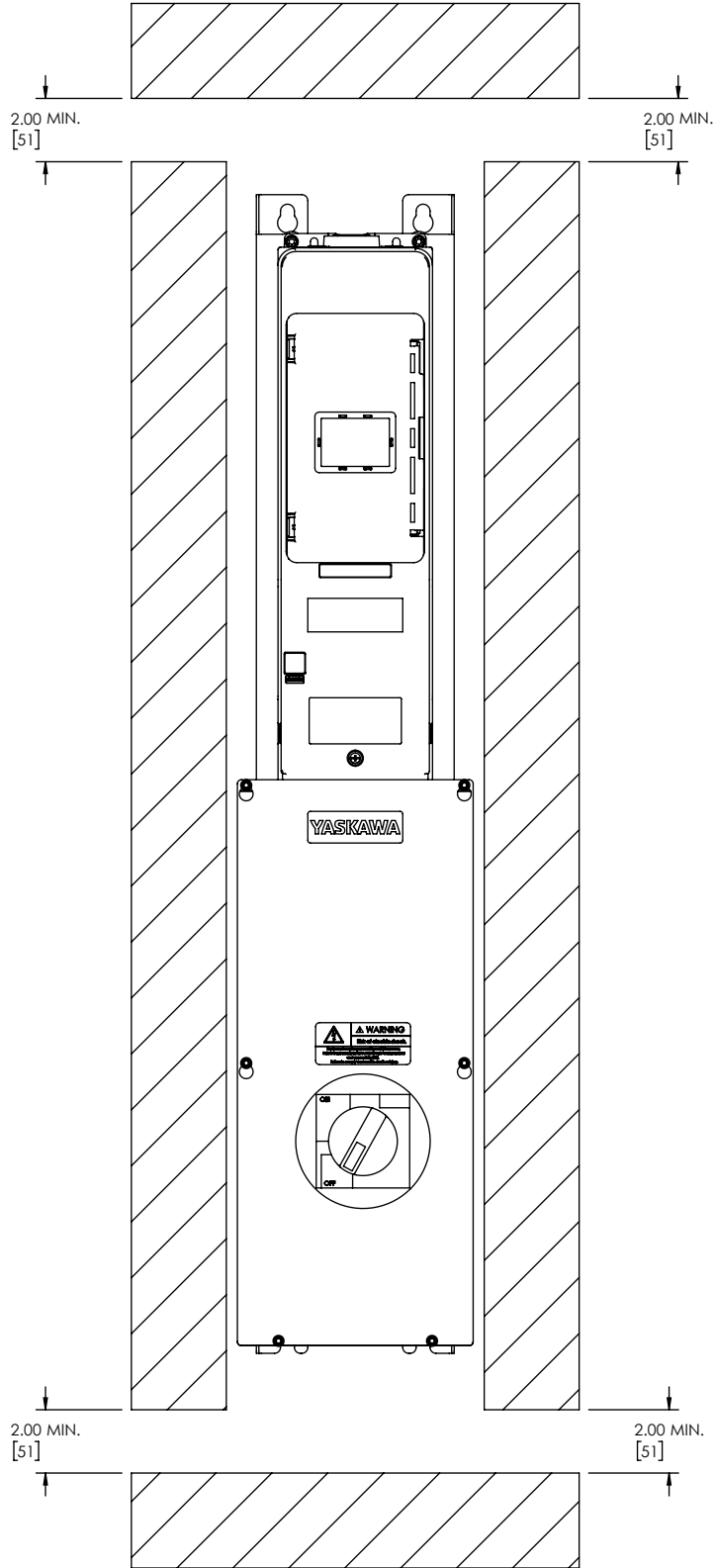

- NOTES:
- A. FOR REFERENCE UNLESS PROPERLY ENDORSED. FOR ADDITIONAL DETAILS AND SPECIFICATIONS CONSULT YASKAWA AMERICA, INC.
 - B. DIMENSIONS ARE IN INCHES [MILLIMETERS].
 - C. USE APPROPRIATE TYPE RATED HUBS OR FITTINGS TO MAINTAIN ENCLOSURE RATING.
 - D. HATCHED AREA INDICATES PERMISSIBLE CONDUIT ENTRANCE AREA.
 - E. IF ENCLOSURE IS MOUNTED USING THE MINIMUM SPECIFIED TOP, BOTTOM, LEFT AND RIGHT CLEARANCES, THEN VENTILATION OPENINGS WILL NEED TO BE PROVIDED AT THE CORNERS AS SHOWN ON PAGE 2.

YASKAWA <small>THIS DOCUMENT AND INFORMATION CONTAINED IN IT ARE CONFIDENTIAL AND CANNOT BE COPIED OR DISCLOSED IN WHOLE OR IN PART WITHOUT THE EXPRESS WRITTEN CONSENT OF YASKAWA AMERICA, INC.</small>	ORIGINAL DESIGN: D. Guckenberger	DATE: 5/10/2022	TITLE: DIMENSION DRAWING, HV600, NARROW, TYPE 12, CONFIGURED, W2		
	DRAWN: D. Guckenberger	DATE: 5/10/2022	SIZE: B	REVISION: 01	PAGE: 1 OF 2
	CHECKED: P. Johnson	DATE: 5/17/2022	DRAWING #:		
UNITS: INCHES	SCALE: NONE	APPROVED: R. Jensen	DATE: 5/18/2022	DD.HC.12.W2.01	



 <p><small>THIS DOCUMENT AND INFORMATION CONTAINED IN IT ARE CONFIDENTIAL AND CANNOT BE COPIED OR DISCLOSED IN WHOLE OR IN PART WITHOUT THE EXPRESS WRITTEN CONSENT OF YASKAWA AMERICA INC.</small></p>	ORIGINAL DESIGN: D. Guckenberger	DATE: 5/10/2022	TITLE: DIMENSION DRAWING, HV600, NARROW, TYPE 12, CONFIGURED, W2		
	DRAWN: D. Guckenberger	DATE: 5/10/2022	SIZE: B	REVISION: 01	PAGE: 2 OF 2
UNITS: INCHES	SCALE: NONE	CHECKED: P. Johnson	DATE: 5/17/2022	DRAWING #:	
		APPROVED: R. Jensen	DATE: 5/18/2022	DD.HC.12.W2.01	