

NOTES:
 A. FOR REFERENCE ONLY UNLESS PROPERLY ENDORSED. FOR ADDITIONAL DETAILS AND SPECIFICATIONS, CONSULT FACTORY.
 B. DIMENSIONS ARE IN INCHES[MILLIMETERS]

paul_johnson Monday, June 15, 2015 7:39:14 AM

| | | | | | | | |
|---|-----------------|--------------------------------|------------------|---|-----------------|----------|--------|
| | | DRAWN: P. Johnson | DATE 06/05/15 | TITLE: DIMENSION DRAWING, Z1000U, TYPE 3R, W1 | | | |
| | | CHECKED: D. Guckenberger | DATE 06/08/15 | | | | |
| REVISIONS | | TECH: | | MATERIAL# | | | |
| REV. | DESCRIPTION | ECR# | DRAWN BY | DATE | SIZE | REVISION | PAGE |
| 00 | INITIAL RELEASE | ---- | PSJ | 6/4/2015 | A | 00 | 1 OF 2 |
| THIS DOCUMENT AND INFORMATION CONTAINED IN IT ARE CONFIDENTIAL, AND CANNOT BE COPIED OR DISCLOSED IN WHOLE OR IN PART WITHOUT THE EXPRESS WRITTEN CONSENT OF YASKAWA AMERICA INC. | | APPROVED: K. Flierl | | DATE 06/09/15 | DRAWING #: | | |
| | | ORIGINAL DESIGN: P. Johnson | | DATE 06/05/15 | DD.Z1U.3R.W1.01 | | |

| REV. | DESCRIPTION | ECR# | DRAWN BY | DATE |
|------|-----------------|------|----------|----------|
| 00 | INITIAL RELEASE | ---- | PSJ | 6/4/2015 |

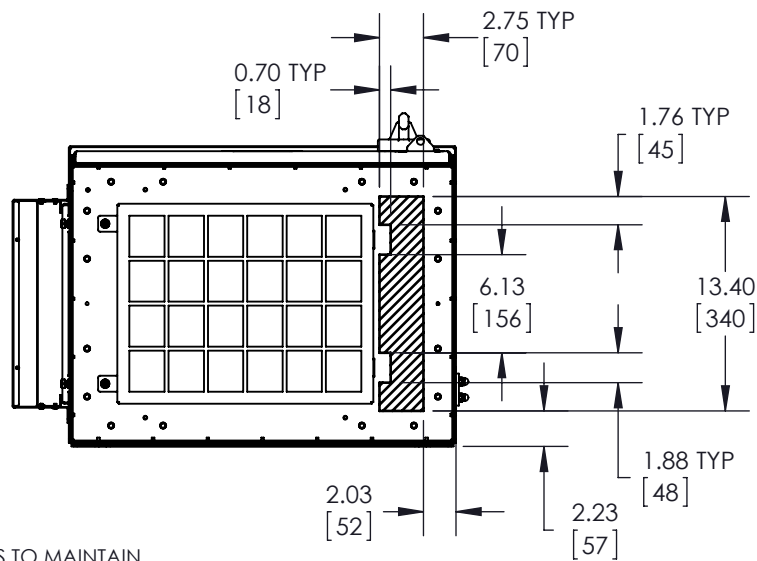
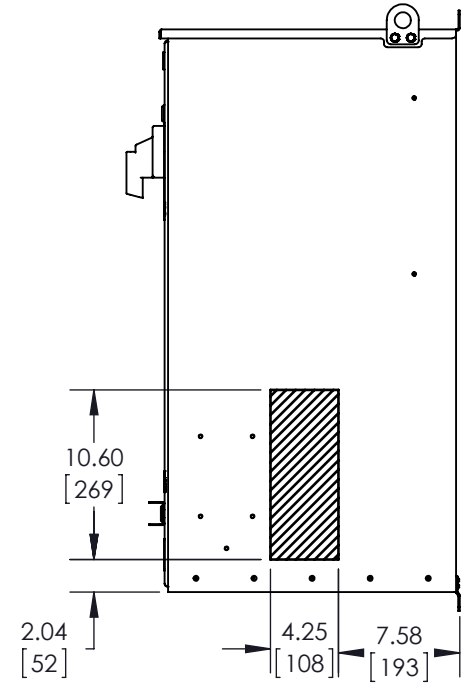
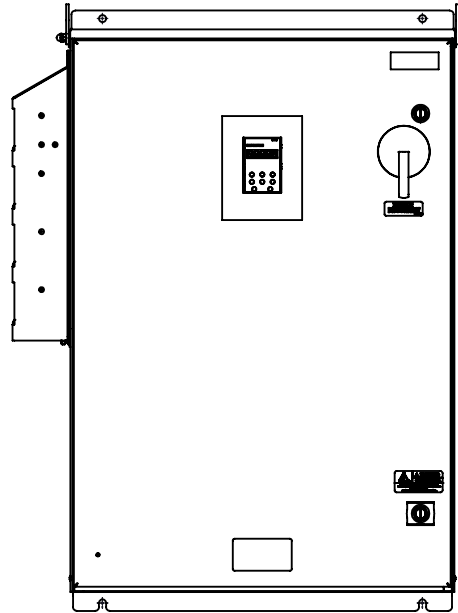
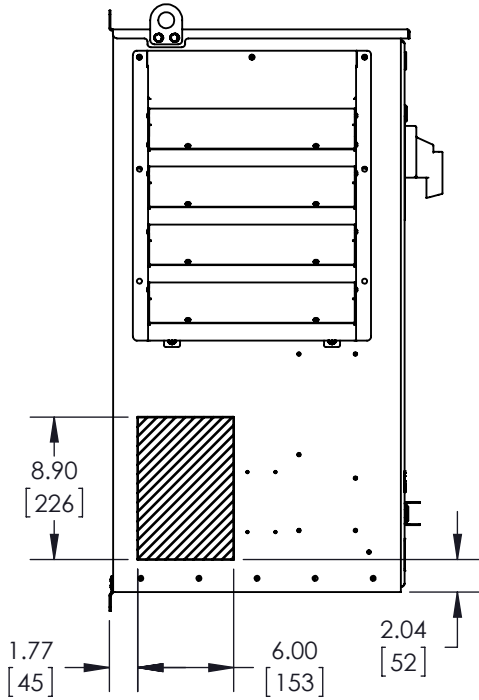
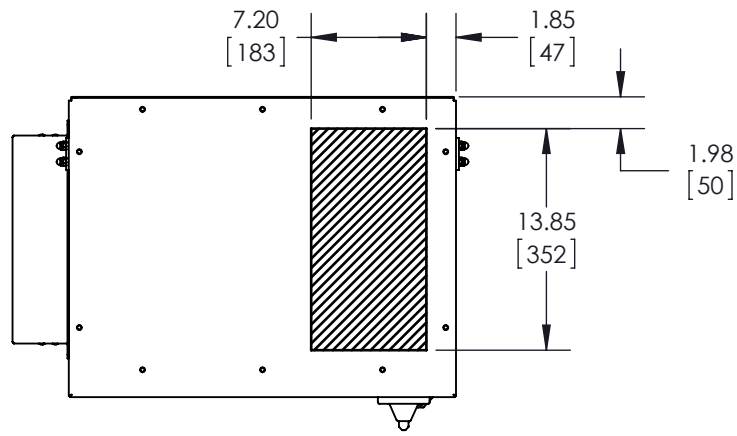

- NOTES:
 C. USE APPROPRIATE TYPE RATED HUBS OR FITTINGS TO MAINTAIN ENCLOSURE RATING.
 D. HATCHED AREA INDICATES PERMISSIBLE CONDUIT ENTRANCE AREA

Paul Johnson Monday, June 15, 2015 7:39:14 AM

| | | | | | |
|--|---------------------------------------|--------------------------|---|-----------------------|-----------------------|
| <p>THIS DOCUMENT AND INFORMATION CONTAINED IN IT ARE CONFIDENTIAL, AND CANNOT BE COPIED OR DISCLOSED IN WHOLE OR IN PART WITHOUT THE EXPRESS WRITTEN CONSENT OF YASKAWA AMERICA INC.</p> | DRAWN: P. Johnson | DATE: 06/05/15 | TITLE: DIMENSION DRAWING, Z1000U, TYPE 3R, W1 | | |
| | CHECKED: D. Guckenberger | DATE: 06/08/15 | MATERIAL# | | |
| | APPROVED: K. Flierl | DATE: 06/09/15 | SIZE A | REVISION 00 | PAGE 2 OF 2 |
| | ORIGINAL DESIGN: P. Johnson | DATE: 06/05/15 | DRAWING #: DD.Z1U.3R.W1.01 | | |