

NOTES:
 A. FOR REFERENCE ONLY UNLESS PROPERLY ENDORSED. FOR ADDITIONAL DETAILS AND SPECIFICATIONS, CONSULT FACTORY.
 B. DIMENSIONS ARE IN INCHES[MILLIMETERS]

paul_johnson Monday, June 15, 2015 8:11:48 AM

YASKAWA

DRAWN: P. Johnson
 CHECKED: D. Guckenberger
 TECH:
 APPROVED: K. Flierl
 ORIGINAL DESIGN: P. Johnson
 DATE: 06/05/15
 DATE: 06/08/15
 DATE: 06/09/15
 DATE: 06/05/15

TITLE: DIMENSION DRAWING, Z1000U, TYPE 3R, W3
 MATERIAL#
 SIZE: A
 REVISION: 00
 PAGE: 1 OF 2
 DRAWING #: DD.Z1U.3R.W3.01

REVISIONS

REV.	DESCRIPTION	ECR#	DRAWN BY	DATE
00	INITIAL RELEASE	----	PSJ	6/4/2015

THIS DOCUMENT AND INFORMATION CONTAINED IN IT ARE CONFIDENTIAL, AND CANNOT BE COPIED OR DISCLOSED IN WHOLE OR IN PART WITHOUT THE EXPRESS WRITTEN CONSENT OF YASKAWA AMERICA INC.

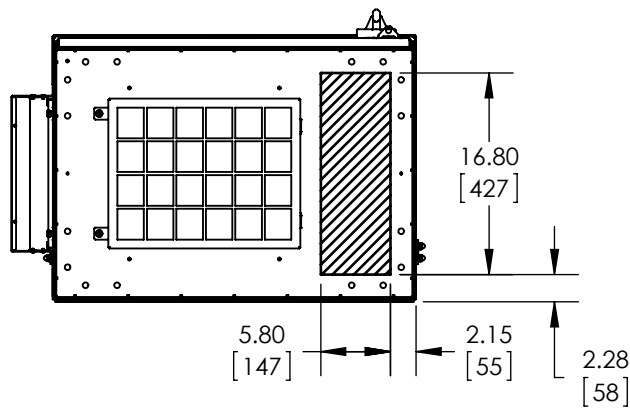
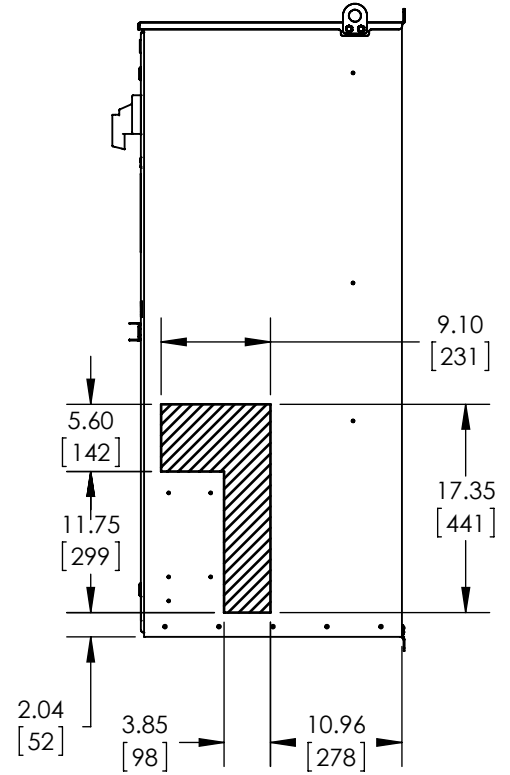
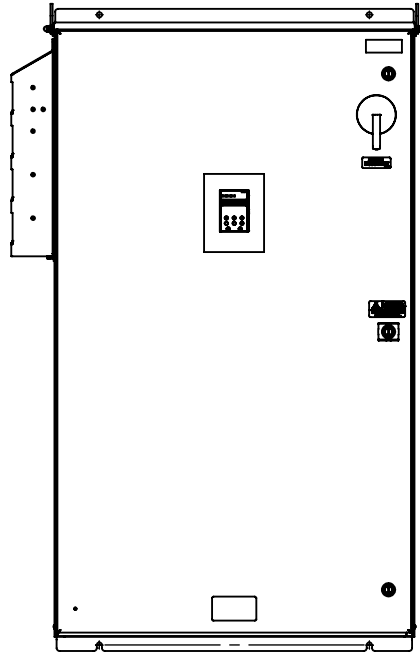
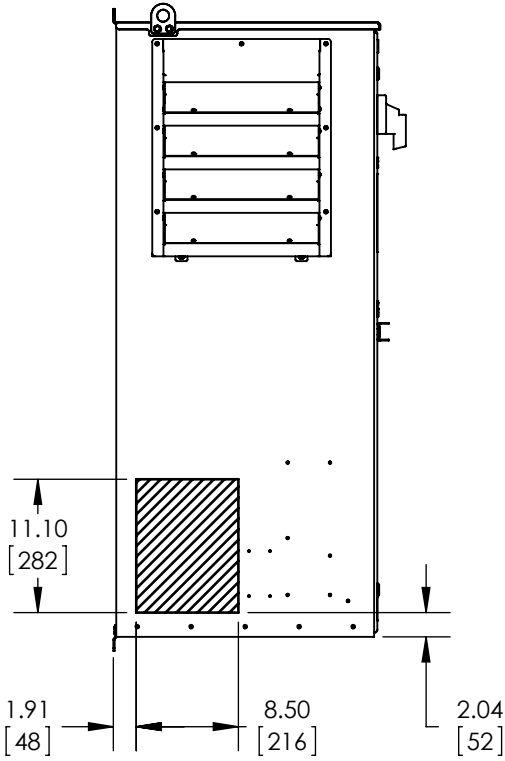
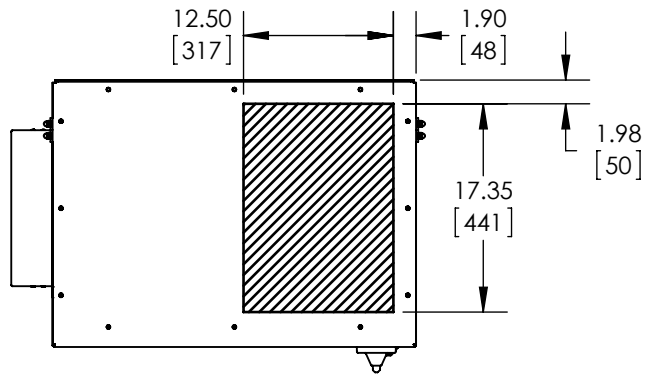

- NOTES:
 C. USE APPROPRIATE TYPE RATED HUBS OR FITTINGS TO MAINTAIN ENCLOSURE RATING.
 D. HATCHED AREA INDICATES PERMISSIBLE CONDUIT ENTRANCE AREA

paul_johnson Monday, June 15, 2015 8:11:48 AM

 <small>THIS DOCUMENT AND INFORMATION CONTAINED IN IT ARE CONFIDENTIAL, AND CANNOT BE COPIED OR DISCLOSED IN WHOLE OR IN PART WITHOUT THE EXPRESS WRITTEN CONSENT OF YASKAWA AMERICA INC.</small>	DRAWN: P. Johnson	DATE: 06/05/15	TITLE: DIMENSION DRAWING, Z1000U, TYPE 3R, W3		
	CHECKED: D. Guckenberger	DATE: 06/08/15	MATERIAL#		
	TECH: P. Johnson	DATE: 06/05/15	SIZE A	REVISION 00	PAGE 2 OF 2
	APPROVED: K. Flierl	DATE: 06/09/15	DRAWING #: DD.Z1U.3R.W3.01		