

NOTES:  
 A. FOR REFERENCE ONLY UNLESS PROPERLY ENDORSED. FOR ADDITIONAL DETAILS AND SPECIFICATIONS, CONSULT FACTORY.  
 B. DIMENSIONS ARE IN INCHES[MILLIMETERS]

paul\_johnson Monday, June 15, 2015 8:17:42 AM

**YASKAWA**

DRAWN: P. Johnson	DATE 06/05/15
CHECKED: D. Guckenberger	DATE 06/08/15
TECH:	DATE
APPROVED: K. Flierl	DATE 06/09/15
ORIGINAL DESIGN: P. Johnson	DATE 06/05/15

TITLE: DIMENSION DRAWING, Z1000U, TYPE 3R, W4		
MATERIAL#	SIZE A	REVISION 00
DRAWING #:		PAGE 1 OF 2
DD.Z1U.3R.W4.01		

REVISIONS				
REV.	DESCRIPTION	ECR#	DRAWN BY	DATE
00	INITIAL RELEASE	----	PSJ	6/4/2015

THIS DOCUMENT AND INFORMATION CONTAINED IN IT ARE CONFIDENTIAL, AND CANNOT BE COPIED OR DISCLOSED IN WHOLE OR IN PART WITHOUT THE EXPRESS WRITTEN CONSENT OF YASKAWA AMERICA INC.

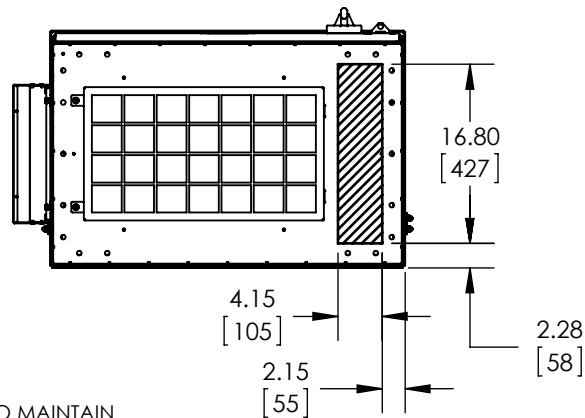
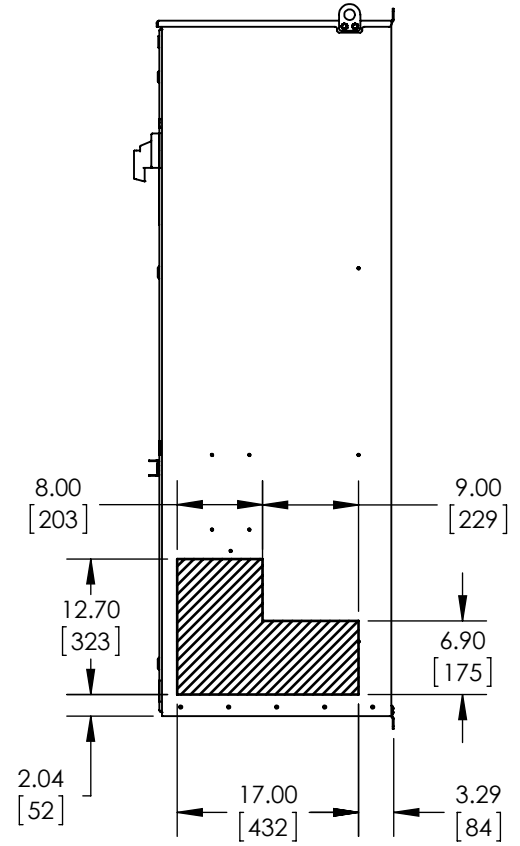
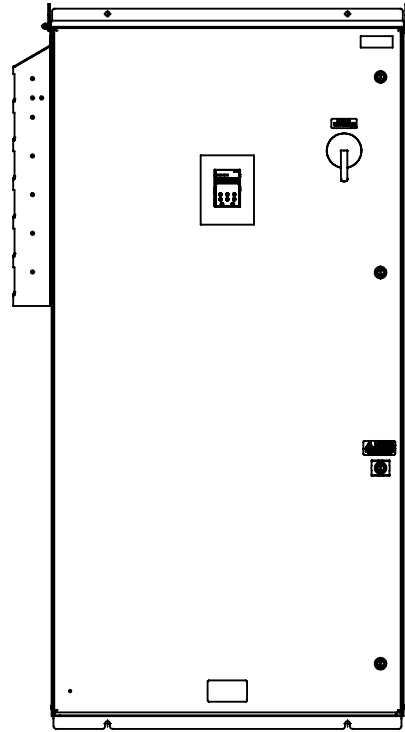
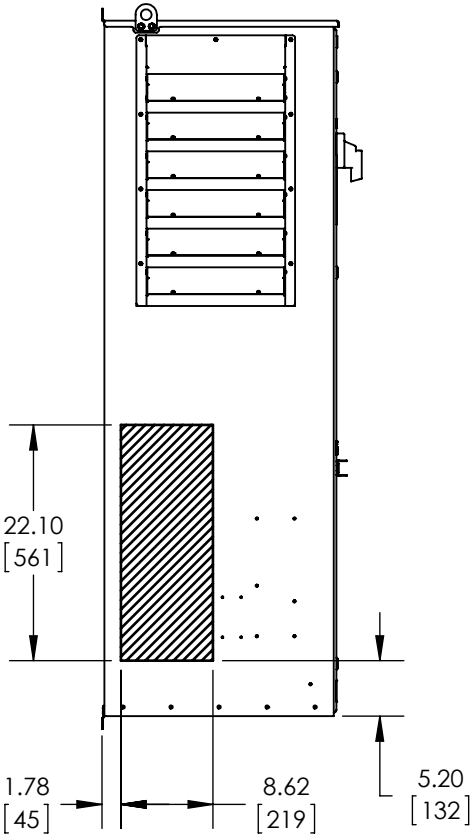
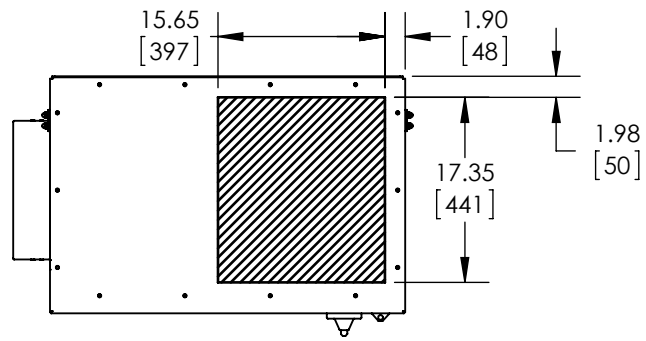

- NOTES:  
 C. USE APPROPRIATE TYPE RATED HUBS OR FITTINGS TO MAINTAIN ENCLOSURE RATING.  
 D. HATCHED AREA INDICATES PERMISSIBLE CONDUIT ENTRANCE AREA

Paul Johnson Monday, June 15, 2015 8:17:42 AM

<b>YASKAWA</b>	DRAWN: P. Johnson	DATE 06/05/15	TITLE: DIMENSION DRAWING, Z1000U, TYPE 3R, W4	
	CHECKED: D. Guckenberger	DATE 06/08/15		
THIS DOCUMENT AND INFORMATION CONTAINED IN IT ARE CONFIDENTIAL, AND CANNOT BE COPIED OR DISCLOSED IN WHOLE OR IN PART WITHOUT THE EXPRESS WRITTEN CONSENT OF YASKAWA AMERICA INC.	TECH:	DATE	MATERIAL#	
	APPROVED: K. Flierl	DATE 06/09/15	SIZE A	REVISION 00
	ORIGINAL DESIGN: P. Johnson	DATE 06/05/15	PAGE 2 OF 2	
			DRAWING #: DD.Z1U.3R.W4.01	