

INPUT VOLTS	TERMINALS		JUMPER LOCATION
	A	B	
230/240	(H1)	(H4)	(H1) TO (H3) (H2) TO (H4)
460/480	(H1)	(H4)	(H2) TO (H3)
600	(H1)	(H2)	NONE

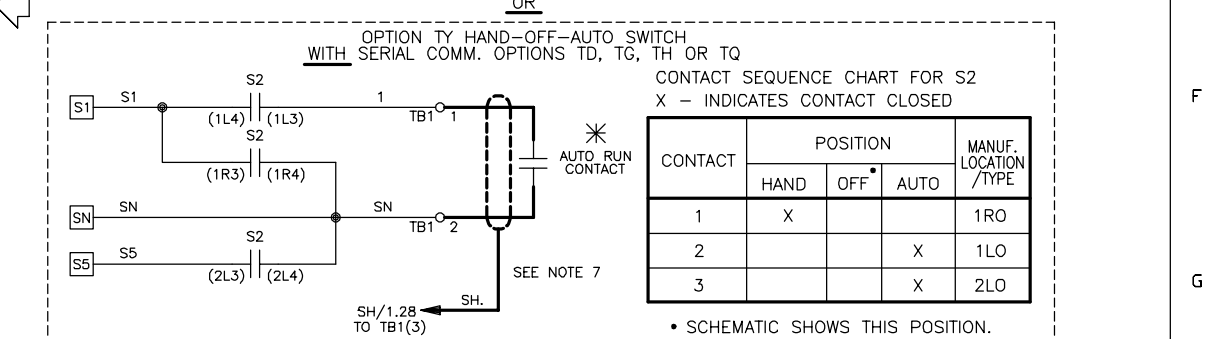
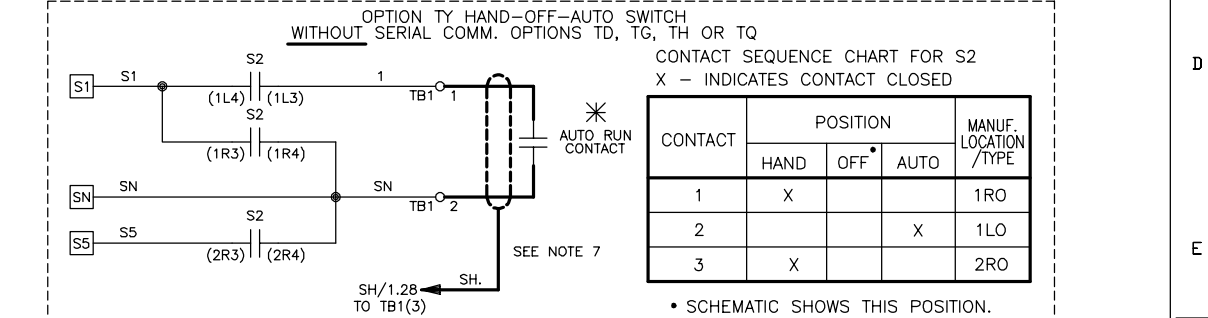

- NOTES:
- CONNECTED TO THE CABINET. CUSTOMER TO CONNECT THE CABINET GROUND LUGS TO EARTH GROUND AND UTILITY GROUND.
 - CONDUIT FITTINGS/HUBS SHALL COMPLY WITH THE STANDARD FOR CONDUIT, TUBING, AND CABLE FITTINGS, UL 514B. OR CONDUIT FITTINGS HAVING THE SAME ENVIRONMENTAL RATING AS THE ENCLOSURE SHALL BE USED.
 - WITHOUT THE CIRCUIT BREAKER (OPTION PC OR PE), OR DISCONNECT SWITCH OPTION PD, THE DISCONNECT MEANS MUST BE SUPPLIED BY THE CUSTOMER.
 - GROUND-FAULT PROTECTION IS PROVIDED FOR THIS ENTIRE CIRCUIT WHEN A CIRCUIT BREAKER (OPTION PC OR PE) IS PROVIDED BY YASKAWA.
 - IF THIS CABINET IS WIRED TO A 3 PHASE, 4 WIRE WYE INPUT POWER TRANSFORMER, THEN ORDER NEUTRAL CURRENT TRANSFORMER:
 - A. FOR A 1000 AMP OR 1200 AMP CIRCUIT BREAKER (OPTION PC OR PE): PART NO. UPT000302.
 - B. FOR A 1600 AMP CIRCUIT BREAKER (OPTION PC OR PE): PART NO. UPT000303.
 - BRANCH CIRCUIT PROTECTION TO BE SUPPLIED BY THE CUSTOMER WHEN NOTED ON THE CABINET DATA NAMEPLATE.
 - INSULATED TWISTED SHIELDED WIRE IS REQUIRED. SHIELD TO CONNECT TO PROPER TERMINALS AS SHOWN. CONNECT THE SHIELD ONLY AT THIS END. STUB AND ISOLATE THE OTHER END. DO NOT RUN THESE WIRES IN THE SAME CONDUIT AS THE AC POWER AND AC CONTROL WIRES. KEEP ALL WIRING UNDER 50m IN LENGTH.
 - CUSTOMER TO ADJUST THE THERMOSTAT ON THE SPACE HEATERS HR1 AND HR2 FOR THE MINIMUM DESIRED TEMPERATURE INSIDE THE DRIVE CABINET. THIS SET TEMPERATURE IS NORMALLY SELECTED TO BE SLIGHTLY HIGHER THAN THE MINIMUM AMBIENT TEMPERATURE OF THE AIR SURROUNDING THE CABINET, AND IS THE TEMPERATURE AT WHICH THE SPACE HEATERS HR1 AND HR2 WILL SHUT OFF.
 - IF AC MOTOR IS FURNISHED WITH A N.C. THERMAL SWITCH THEN SET DRIVE PARAMETER H1-08 TO 27. THIS WILL CAUSE THE DRIVE TO COAST TO STOP UPON AN AC MOTOR THERMAL FAULT. ALONG WITH THIS, ADD THE FOLLOWING CUSTOMER WIRING: WIRE THE N.C. THERMAL SWITCH BETWEEN DRIVE TERMINALS S8 AND SN, AS PER NOTE 7 ABOVE.
 - OPTIONS TD, TG, TH OR TQ CONTROL (SEE UDE00338 FOR MORE INFORMATION)

REVISIONS				
REV.	DESCRIPTION	ECO #	DRAWN BY	DATE
05	CHANGED REACTOR L4 TERMINAL DESIGNATORS	7696	R. ROH	11/15/17
04	UPDATE CUSTOMER CONNECTIONS TO BOLD LINES	6620	DJP	10/07/15
03	ADDED FM, AM, MP TERMINALS TO DRIVE	6422	DJP	07/17/15

YASKAWA

THIS DOCUMENT AND INFORMATION CONTAINED IN IT ARE CONFIDENTIAL, AND CANNOT BE COPIED OR DISCLOSED IN WHOLE OR IN PART WITHOUT THE EXPRESS WRITTEN CONSENT OF YASKAWA AMERICA INC.

DRAWN BY: D.R. CMELAK	DATE: 11/28/12	TITLE: SCHEMATIC DIAGRAM A1000 CONFIGURED HIGH HORSEPOWER TYPE 3R
CHECKED: D. PACKER	DATE: 11/28/12	SIZE: D
APPROVED: K. FLIERL	DATE: 11/28/12	REVISION: 05
ORIGINAL DESIGN: D.R. CMELAK	DATE: 11/28/12	PAGE: 1 of 1