

REVISIONS			
REV.	DESCRIPTION	ECO #	DRAWN BY DATE
04	ADDED K7 DRIVE RUN RELAY	13127	RJJ 6/12/23
03	REVISED NOTES 1 AND 2, TB1 TERMS, & PG BASE #S.	13075	RJJ 5/16/23
02	MOVED FE WIRE FROM TZ AND TURNED ON S2	12896	KJL 2/23/23

**YASKAWA**

DRAWN BY: E. ACKERMAN	DATE: 6/2/22	TITLE: SCHEMATIC DIAGRAM FP605 TYPE 3R ELECTRONIC BYPASS
CHECKED BY: K. MALUSIC	DATE: 7/15/22	TECH:
APPROVED BY: R. JENSEN	DATE: 8/4/22	SIZE: D
ORIGINAL DESIGN: E. ACKERMAN	DATE: 6/2/22	REVISION: 04
		PAGE: 1 of 2
		DRAWING #: DS.F6B3.01

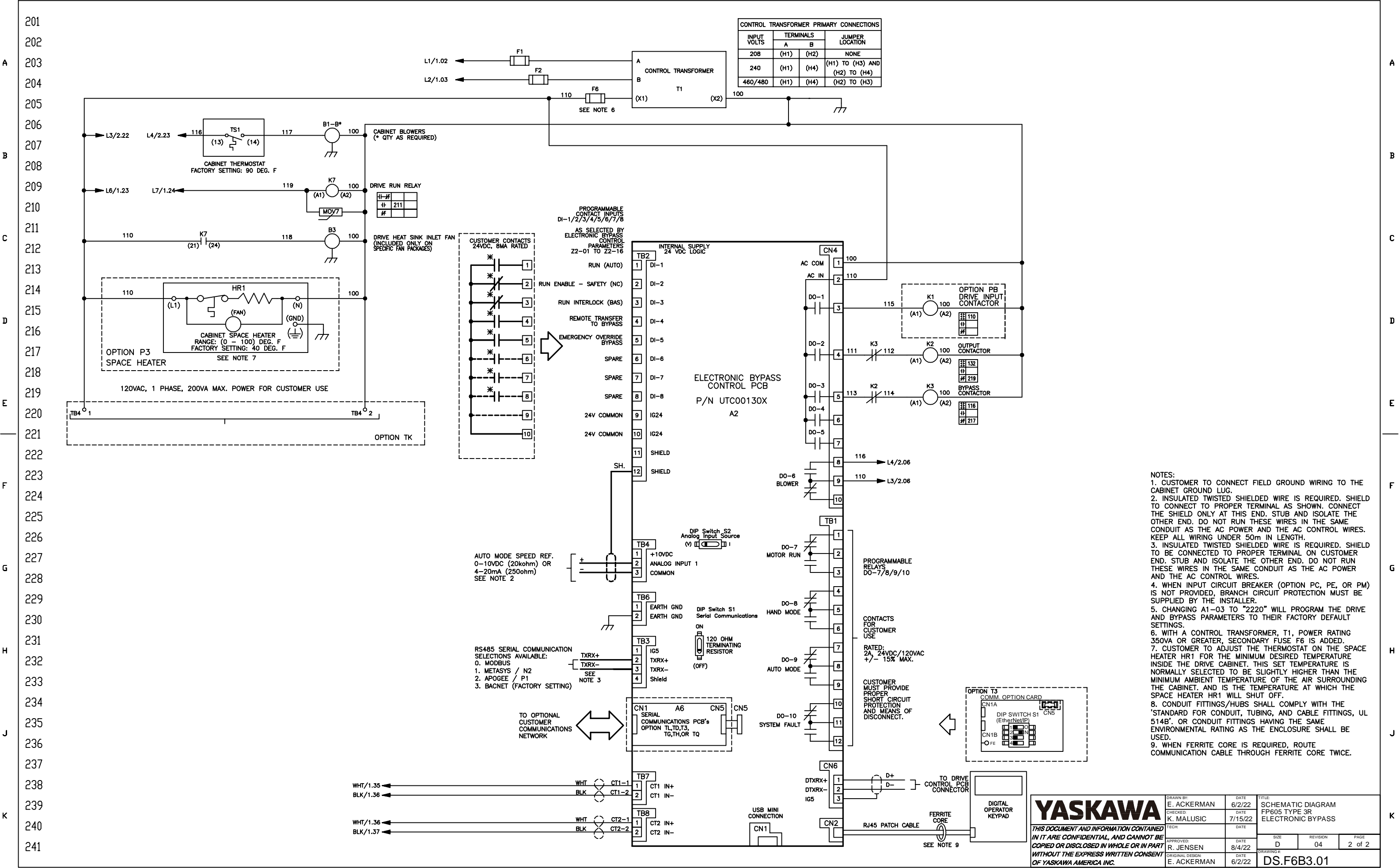

- NOTES:**
- CUSTOMER TO CONNECT FIELD GROUND WIRING TO THE CABINET GROUND LUG.
  - INSULATED TWISTED SHIELDED WIRE IS REQUIRED. SHIELD TO CONNECT TO PROPER TERMINAL AS SHOWN. CONNECT THE SHIELD ONLY AT THIS END. STUB AND ISOLATE THE OTHER END. DO NOT RUN THESE WIRES IN THE SAME CONDUIT AS THE AC POWER AND THE AC CONTROL WIRES. KEEP ALL WIRING UNDER 50m IN LENGTH.
  - INSULATED TWISTED SHIELDED WIRE IS REQUIRED. SHIELD TO BE CONNECTED TO PROPER TERMINAL ON CUSTOMER END. STUB AND ISOLATE THE OTHER END. DO NOT RUN THESE WIRES IN THE SAME CONDUIT AS THE AC POWER AND THE AC CONTROL WIRES.
  - WHEN INPUT CIRCUIT BREAKER (OPTION PC, PE, OR PM) IS NOT PROVIDED, BRANCH CIRCUIT PROTECTION MUST BE SUPPLIED BY THE INSTALLER.
  - CHANGING A1-03 TO "2220" WILL PROGRAM THE DRIVE AND BYPASS PARAMETERS TO THEIR FACTORY DEFAULT SETTINGS.
  - WITH A CONTROL TRANSFORMER, T1, POWER RATING 350VA OR GREATER, SECONDARY FUSE F6 IS ADDED.
  - CUSTOMER TO ADJUST THE THERMOSTAT ON THE SPACE HEATER HR1 FOR THE MINIMUM DESIRED TEMPERATURE INSIDE THE DRIVE CABINET. THIS SET TEMPERATURE IS NORMALLY SELECTED TO BE SLIGHTLY HIGHER THAN THE MINIMUM AMBIENT TEMPERATURE OF THE AIR SURROUNDING THE CABINET. AND IS THE TEMPERATURE AT WHICH THE SPACE HEATER HR1 WILL SHUT OFF.
  - CONDUIT FITTINGS/HUBS SHALL COMPLY WITH THE 'STANDARD FOR CONDUIT, TUBING, AND CABLE FITTINGS, UL 514B' OR CONDUIT FITTINGS HAVING THE SAME ENVIRONMENTAL RATING AS THE ENCLOSURE SHALL BE USED.
  - WHEN FERRITE CORE IS REQUIRED, ROUTE COMMUNICATION CABLE THROUGH FERRITE CORE TWICE.

**YASKAWA**

THIS DOCUMENT AND INFORMATION CONTAINED IN IT ARE CONFIDENTIAL, AND CANNOT BE COPIED OR DISCLOSED IN WHOLE OR IN PART WITHOUT THE EXPRESS WRITTEN CONSENT OF YASKAWA AMERICA INC.

DRAWN BY: E. ACKERMAN	DATE: 6/2/22	TITLE: SCHEMATIC DIAGRAM
CHECKED BY: K. MALUSIC	DATE: 7/15/22	FP605 TYPE 3R
APPROVED BY: R. JENSEN	DATE: 8/4/22	ELECTRONIC BYPASS
ORIGINAL DESIGNER: E. ACKERMAN	DATE: 6/2/22	

SIZE: D	REVISION: 04	PAGE: 2 of 2
DRAWING #: DS.F6B3.01		