

CONTROL TRANSFORMER PRIMARY CONNECTIONS			
INPUT VOLTS	TERMINALS		JUMPER LOCATION
	A	B	
230/240	(H1)	(H4)	(H1) TO (H3) (H2) TO (H4)
460/480	(H1)	(H4)	(H2) TO (H3)
600	(H1)	(H2)	NONE

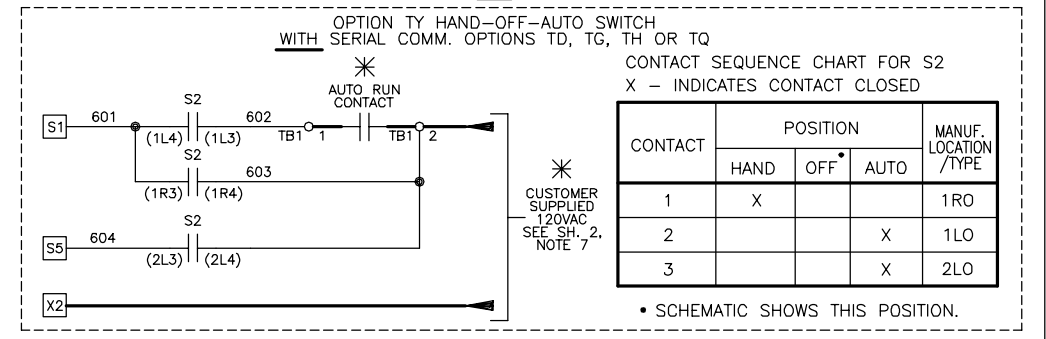

BLOWER MOTOR		
FLA RATING	AMPS	VOLTS
3.0	4.2 - 360	240
1.5	2.1 - 477	480
3.0	5.15 - 720	480

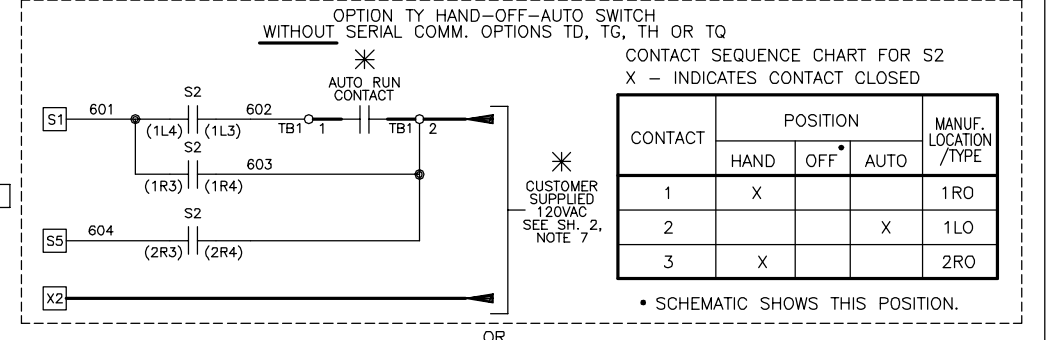
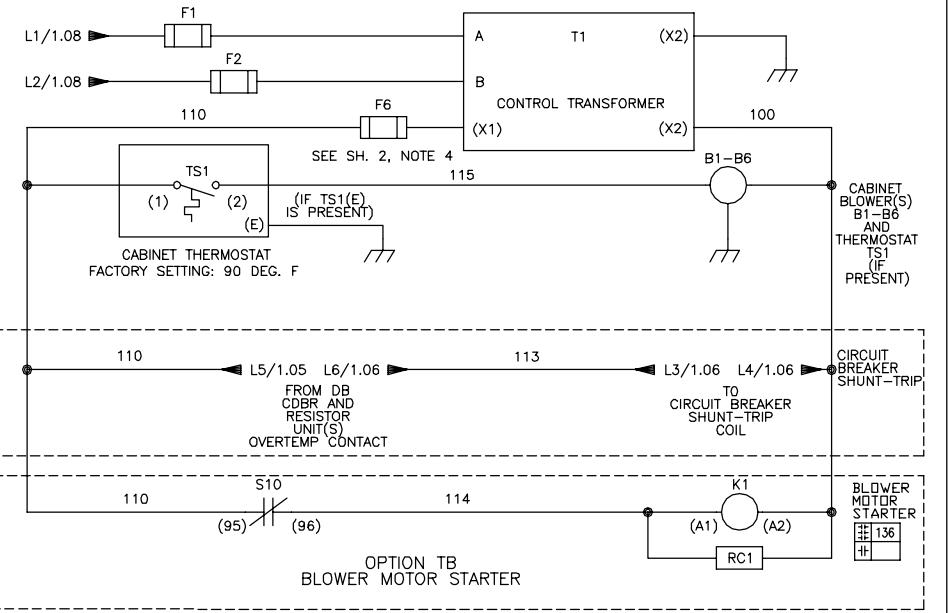
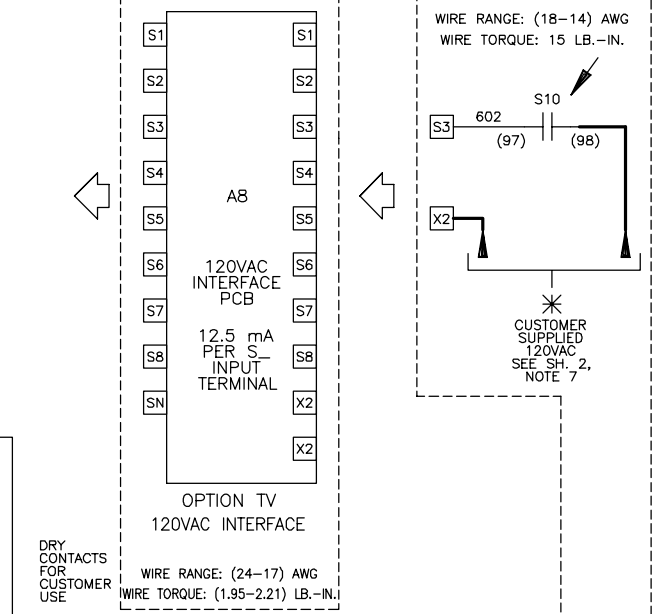
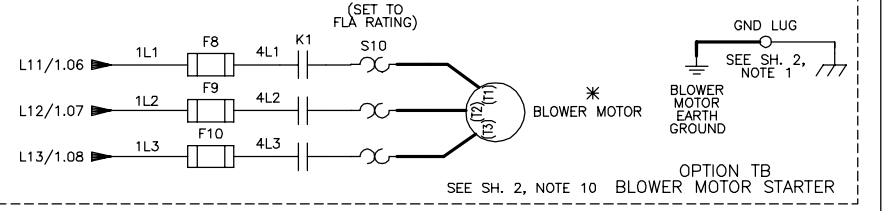

WIRE RANGE: (18-14) AWG
WIRE TORQUE: 15 LB.-IN.

WIRE RANGE: (24-17) AWG
WIRE TORQUE: (1.95-2.21) LB.-IN.

OPTION TV
120VAC INTERFACE

OPTION TY HAND-OFF-AUTO SWITCH
WITHOUT SERIAL COMM. OPTIONS TD, TG, TH OR TQ
CONTACT SEQUENCE CHART FOR S2
X - INDICATES CONTACT CLOSED

OPTION TY HAND-OFF-AUTO SWITCH
WITH SERIAL COMM. OPTIONS TD, TG, TH OR TQ
CONTACT SEQUENCE CHART FOR S2
X - INDICATES CONTACT CLOSED

OPTION TB
BLOWER MOTOR STARTER

OPTION TB
BLOWER MOTOR STARTER

* - INDICATES COMPONENTS NOT SUPPLIED BY YASKAWA.
- INDICATES CUSTOMER WIRING.
- CONNECTED TO THE CABINET OR PANEL.
SEE SHEET 2 FOR NOTES.
SEE DRAWING UDE00578 FOR CUSTOMER CONNECTIONS.
SEE DRAWING UDE00579 FOR DRIVE PARAMETER SETTINGS.

REVISIONS			
REV	DESCRIPTION	ECD #	DATE
03	ADDED INPUT FUSES TO B361-B720, NOTE 11	11302	4/13/21
02	ADDED OPTION TB AND FRAME 11 WIRING	10925	10/23/20

DRAWN BY		DATE		TITLE	
K. MALUSIC		8/1/18		SCHEMATIC DIAGRAM G800 CONFIGURED TYPE 1 NORMAL DUTY RATING WITH OPTION PJ AND TV	
CHECKED BY		DATE		SIZE	
N. LAWS		8/1/18		D	
APPROVED BY		DATE		REVISION	
K. FLIERL		8/1/18		03	
ORIGINAL DESIGN		DATE		PAGE	
K. MALUSIC		8/1/18		1 of 2	

THIS DOCUMENT AND INFORMATION CONTAINED
HEREIN IS CONFIDENTIAL AND NOT BE
COPIED OR DISCLOSED IN WHOLE OR IN PART
WITHOUT THE EXPRESS WRITTEN CONSENT
OF YASKAWA AMERICA, INC.

DRAWING # **DS.G8C1.08**

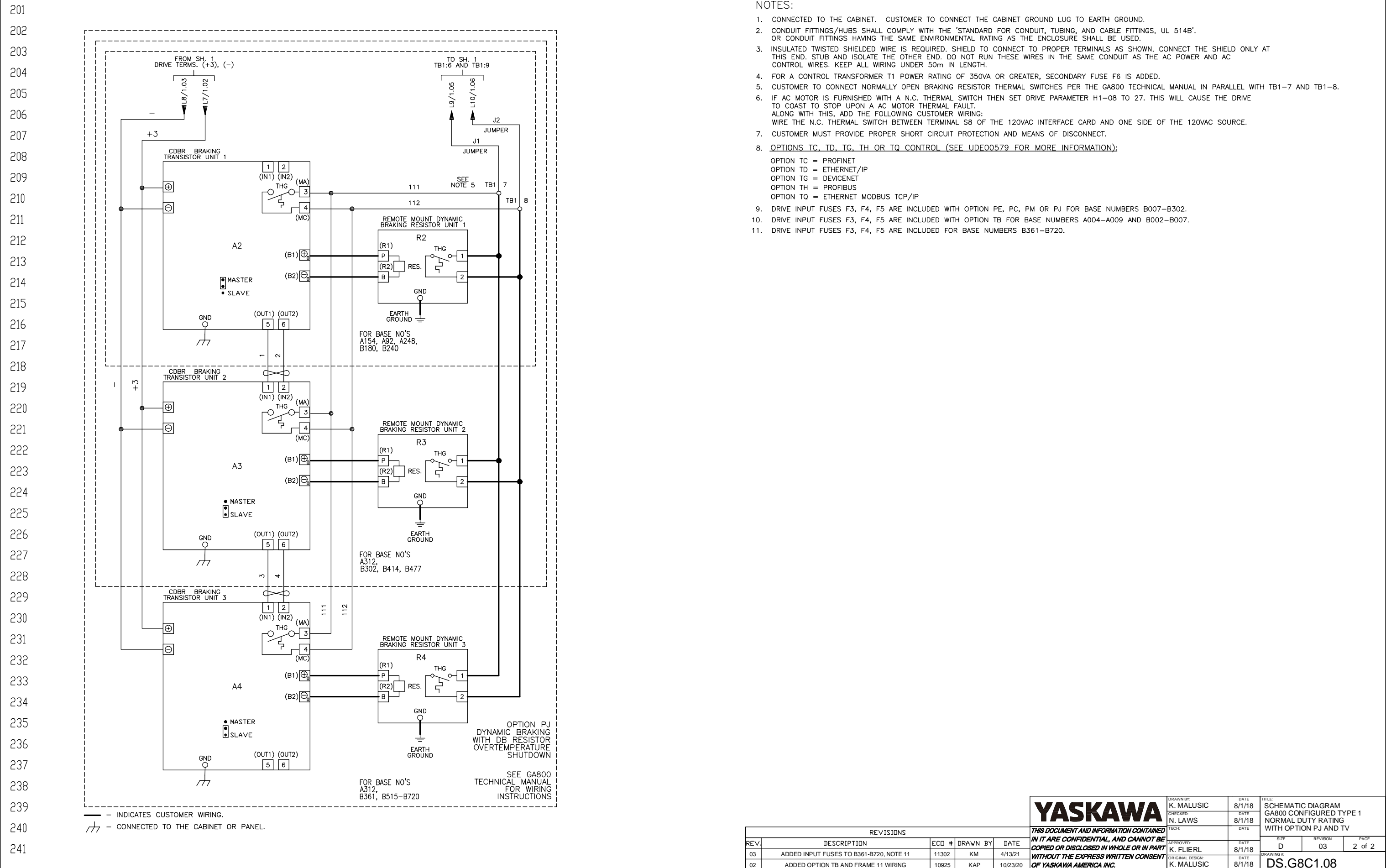

- NOTES:
- CONNECTED TO THE CABINET. CUSTOMER TO CONNECT THE CABINET GROUND LUG TO EARTH GROUND.
 - CONDUIT FITTINGS/HUBS SHALL COMPLY WITH THE 'STANDARD FOR CONDUIT, TUBING, AND CABLE FITTINGS, UL 514B' OR CONDUIT FITTINGS HAVING THE SAME ENVIRONMENTAL RATING AS THE ENCLOSURE SHALL BE USED.
 - INSULATED TWISTED SHIELDED WIRE IS REQUIRED. SHIELD TO CONNECT TO PROPER TERMINALS AS SHOWN. CONNECT THE SHIELD ONLY AT THIS END. STUB AND ISOLATE THE OTHER END. DO NOT RUN THESE WIRES IN THE SAME CONDUIT AS THE AC POWER AND AC CONTROL WIRES. KEEP ALL WIRING UNDER 50m IN LENGTH.
 - FOR A CONTROL TRANSFORMER T1 POWER RATING OF 350VA OR GREATER, SECONDARY FUSE F6 IS ADDED.
 - CUSTOMER TO CONNECT NORMALLY OPEN BRAKING RESISTOR THERMAL SWITCHES PER THE GA800 TECHNICAL MANUAL IN PARALLEL WITH TB1-7 AND TB1-8.
 - IF AC MOTOR IS FURNISHED WITH A N.C. THERMAL SWITCH THEN SET DRIVE PARAMETER H1-08 TO 27. THIS WILL CAUSE THE DRIVE TO COAST TO STOP UPON A AC MOTOR THERMAL FAULT. ALONG WITH THIS, ADD THE FOLLOWING CUSTOMER WIRING: WIRE THE N.C. THERMAL SWITCH BETWEEN TERMINAL S8 OF THE 120VAC INTERFACE CARD AND ONE SIDE OF THE 120VAC SOURCE.
 - CUSTOMER MUST PROVIDE PROPER SHORT CIRCUIT PROTECTION AND MEANS OF DISCONNECT.
 - OPTIONS TC, TD, TG, TH OR TQ CONTROL (SEE UDE00579 FOR MORE INFORMATION):
 OPTION TC = PROFINET
 OPTION TD = ETHERNET/IP
 OPTION TG = DEVICENET
 OPTION TH = PROFIBUS
 OPTION TQ = ETHERNET MODBUS TCP/IP
 - DRIVE INPUT FUSES F3, F4, F5 ARE INCLUDED WITH OPTION PE, PC, PM OR PJ FOR BASE NUMBERS B007-B302.
 - DRIVE INPUT FUSES F3, F4, F5 ARE INCLUDED WITH OPTION TB FOR BASE NUMBERS A004-A009 AND B002-B007.
 - DRIVE INPUT FUSES F3, F4, F5 ARE INCLUDED FOR BASE NUMBERS B361-B720.

YASKAWA

DRAWN BY:	K. MALUSIC	DATE:	8/1/18	TITLE:	SCHEMATIC DIAGRAM
CHECKED:	N. LAWS	DATE:	8/1/18		GA800 CONFIGURED TYPE 1
TECH:		DATE:			NORMAL DUTY RATING
APPROVED:	K. FLIERL	DATE:	8/1/18		WITH OPTION PJ AND TV
ORIGINAL DESIGN:	K. MALUSIC	DATE:	8/1/18		

THIS DOCUMENT AND INFORMATION CONTAINED IN IT ARE CONFIDENTIAL, AND CANNOT BE COPIED OR DISCLOSED IN WHOLE OR IN PART WITHOUT THE EXPRESS WRITTEN CONSENT OF YASKAWA AMERICA INC.

REV	DESCRIPTION	ECD #	DRAWN BY	DATE
03	ADDED INPUT FUSES TO B361-B720, NOTE 11	11302	KM	4/13/21
02	ADDED OPTION TB AND FRAME 11 WIRING	10925	KAP	10/23/20

SIZE	REVISION	PAGE
D	03	2 of 2

DRAWING # **DS.G8C1.08**