

**CONTROL TRANSFORMER PRIMARY CONNECTIONS**

INPUT VOLTS	TERMINALS		JUMPER LOCATION
	A	B	
208	(H1)	(H2)	NONE
460/480	(H1)	(H4)	(H2 TO H3)

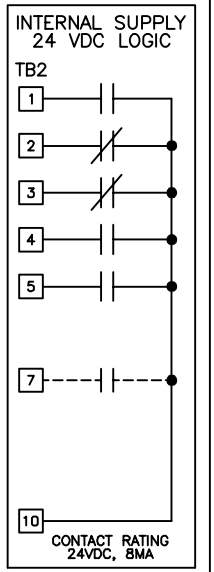

**PROGRAMMABLE CONTACT INPUTS**  
DI-1/2/3/4/5/6/7/8

- DI-1 RUN (AUTO MODE)
- DI-2 RUN ENABLE (SAFETY)
- DI-3 RUN INTERLOCK (BAS)
- DI-4 REMOTE TRANSFER
- DI-5 SMOKE PURGE BYPASS
- DI-6 SPARE
- DI-7 S8
- DI-8 S9

**PROGRAMMABLE RELAYS**  
DO-7/8/9/10

- DO-7 MOTOR RUN
- DO-8 HAND MODE
- DO-9 AUTO MODE
- DO-10 SYSTEM FAULT

**CONTACTS FOR CUSTOMER USE**

RATED: 2A, 24VDC/120VAC +/- 15% MAX.

CUSTOMER MUST PROVIDE PROPER SHORT CIRCUIT PROTECTION AND MEANS OF DISCONNECT.

**AS SELECTED BY ELECTRONIC BYPASS CONTROL PARAMETERS**  
Z2-23 TO Z2-26

**RS485 SERIAL COMMUNICATION SELECTIONS AVAILABLE:**

- MODBUS
- N2 / METASYS
- FLN / APOGEE
- BACNET (FACTORY SETTING)

**HOA OPERATOR**  
PART NUMBER JVOP-183

**DIP SWITCH S1**  
SERIAL COMM. 120 OHM, 1/2 WATT TERMINATING RESISTOR

1 OFF  
2 ON

**REVISIONS**

REV.	DESCRIPTION	ECO #	DRAWN BY	DATE
01	REMOVE TG & TH OPTIONS FROM P1000 BYPASS	12946	JZ	3/9/23
00	INITIAL RELEASE	-	D. PACKER	2/22/14

**YASKAWA**

THIS DOCUMENT AND INFORMATION CONTAINED IN IT ARE CONFIDENTIAL, AND CANNOT BE COPIED OR DISCLOSED IN WHOLE OR IN PART WITHOUT THE EXPRESS WRITTEN CONSENT OF YASKAWA AMERICA INC.

DRAWN BY: D. PACKER	DATE: 2/22/14	TITLE: SCHEMATIC DIAGRAM P1000 ELECTRONIC BYPASS 2-MTR "OR" OPTION PY
CHECKED: D.R. CMELAK	DATE: 2/24/14	
APPROVED: K. FLIERL	DATE: 2/24/14	
ORIGINAL DESIGN: D. PACKER	DATE: 2/22/14	

SIZE: D REVISION: 01 PAGE: 1 of 2

**DS.P1B.3R.11**

\* - INDICATES COMPONENTS NOT SUPPLIED BY YASKAWA.  
 - - INDICATES CUSTOMER WIRING.  
 ⚡ - CONNECTED TO THE CABINET OR PANEL.  
 SEE SHEET 2 FOR NOTES.

A  
B  
C  
D  
E  
F  
G  
H  
J  
K

201  
202  
203  
204  
205  
206  
207  
208  
209  
210  
211  
212  
213  
214  
215  
216  
217  
218  
219  
220  
221  
222  
223  
224  
225  
226  
227  
228  
229  
230  
231  
232  
233  
234  
235  
236  
237  
238  
239  
240  
241

NOTES:

1. CUSTOMER TO CONNECT THE CABINET GROUND LUGS TO EARTH GROUND AND UTILITY GROUND.
2. CONDUIT FITTINGS/HUBS SHALL COMPLY WITH THE 'STANDARD FOR CONDUIT, TUBING, AND CABLE FITTINGS, UL 514B'. OR CONDUIT FITTINGS HAVING THE SAME ENVIRONMENTAL RATING AS THE ENCLOSURE SHALL BE USED.
3. INSULATED TWISTED SHIELDED WIRE IS REQUIRED. SHIELD TO CONNECT TO PROPER TERMINAL AS SHOWN. CONNECT THE SHIELD ONLY AT THIS END. STUB AND ISOLATE THE OTHER END. DO NOT RUN THESE WIRES IN THE SAME CONDUIT AS THE AC POWER AND THE AC CONTROL WIRES.
4. WITH A CONTROL TRANSFORMER, T1, POWER RATING 350VA OR GREATER, SECONDARY FUSE F6 IS ADDED.
5. CHANGING Z1-01 TO "1" WILL PROGRAM THE DRIVE AND BYPASS PARAMETERS TO THEIR FACTORY DEFAULT SETTINGS.
6. SET Z1-11 TO 4 AND Z2-06 TO 27.
7. FOR 208VAC APPLICATIONS, SET E1-01 TO 208, AND SET E1-05 TO 208.
8. THE MOTOR OVERLOAD RELAY IS FACTORY SET FOR MANUAL RESET. CUSTOMER TO ADJUST THE MOTOR OVERLOAD RELAY TRIP SETTING FOR THE ACTUAL AC MOTOR'S FULL LOAD AMPS.
9. CUSTOMER TO ADJUST THE THERMOSTAT ON THE SPACE HEATER HR1 FOR THE MINIMUM DESIRED TEMPERATURE INSIDE THE DRIVE CABINET. THIS SET TEMPERATURE IS NORMALLY SELECTED TO BE SLIGHTLY HIGHER THAN THE MINIMUM AMBIENT TEMPERATURE OF THE AIR SURROUNDING THE CABINET. AND IS THE TEMPERATURE AT WHICH THE SPACE HEATER HR1 WILL SHUT OFF.

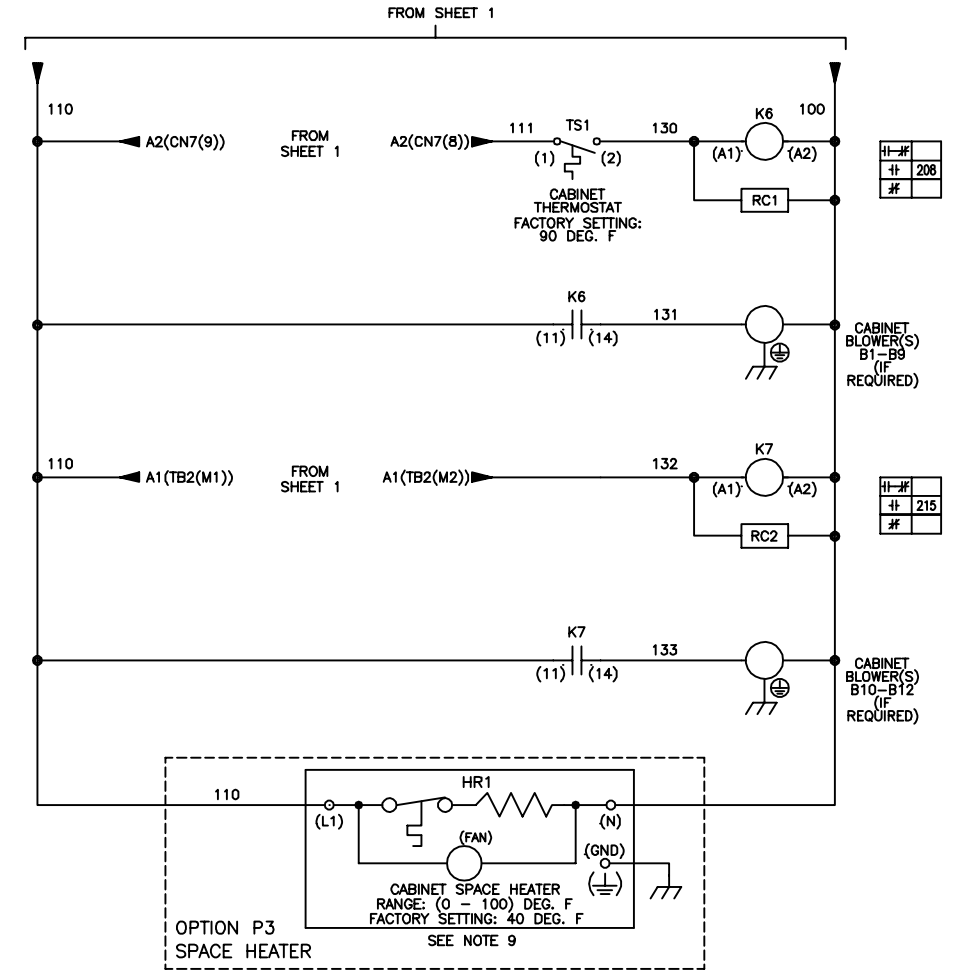

<b>YASKAWA</b>	DRAWN BY: D. PACKER	DATE: 2/22/14	TITLE: SCHEMATIC DIAGRAM
	CHECKED: D.R. CMELAK	DATE: 2/24/14	P1000 ELECTRONIC BYPASS
	TECH:	DATE:	2-MTR "OR"
	APPROVED: K. FLIERL	DATE: 2/24/14	OPTION PY
ORIGINAL DESIGN: D. PACKER		DATE: 2/22/14	DRAWING#: DS.P1B.3R.11
THIS DOCUMENT AND INFORMATION CONTAINED IN IT ARE CONFIDENTIAL, AND CANNOT BE COPIED OR DISCLOSED IN WHOLE OR IN PART WITHOUT THE EXPRESS WRITTEN CONSENT OF YASKAWA AMERICA INC.			SIZE: D REVISION: 01 PAGE: 2 of 2