

Introduction

This instruction sheet applies to the Option Extension Ring Kit for the GPD315/V74X (herein after called the “Drive”). The extension ring is mounted between the face cover and the heat sink of the Drive. It is used to provide additional space within the Drive so that option card kits may be installed. For details on the option cards, refer to the specified installation guides for each option card. Details on mounting or wiring the Drive can be found in Technical Manual TM.V7.01.



HAZARDOUS VOLTAGE CAN CAUSE SEVERE INJURY OR DEATH. LOCK ALL POWER SOURCES DRIVE IN “OFF” POSITION.



- To prevent physical damage to the Drive, Read these instructions thoroughly before installing.
- An internal, operator cable connects the face cover to the Drive. Remove the face cover slowly.
- After installing the ring collar kit, ensure all screws are tightened and the face cover is securely in place.

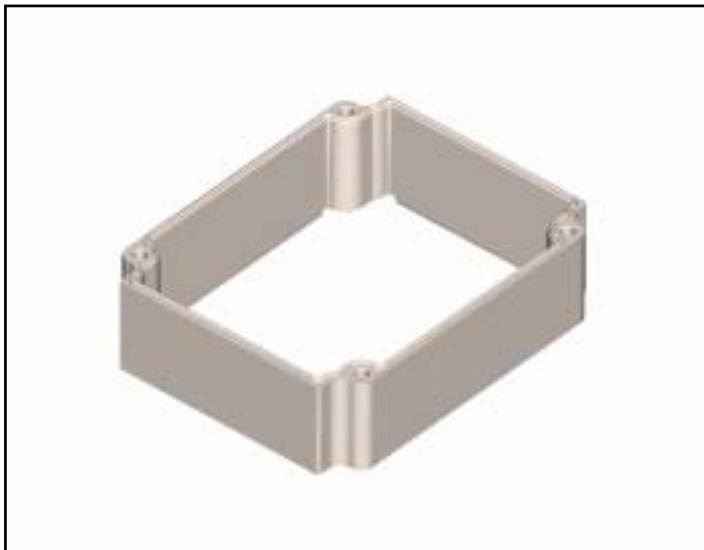

Ring Collar Kit Part Numbers

Extension Ring Kit Part No.	Applicable Drive Models		Parts Included	Qty
	CIMR-V7CU □□□□	HP		
UUX000060	20P1	0.13	Extension Ring Screws (M4 x 70 SW) O-Rings	1 4 4
	20P2	0.25		
	20P4	0.5		
	20P7	1.0		
	40P2	2.0		
	40P4	3.0		
	40P7	5.0		
UUX000061	21P5	0.25	Extension Ring Screws (M4 x 70 SW) O-Rings	1 4 4
	22P2	0.5		
	23P7	1.0		
	41P5	3.0		
	42P2	4.0		
	43P7	5.0		

Ring Collar Kit Installation

- (1) Turn OFF the power supply to the Drive

Refer to Figure 1 – Removal of components

- (2) Remove the screw-hole caps located at each corner of the face cover of the drive.
- (3) Loosen the screws located at each corner of the face cover of the drive. O-rings on the backside of the face cover will not allow the screws to be completely removed.
- (4) *Partially* lift the face cover off the drive. An internal, operator cable connects the face cover to the Drive. Disconnect the cable at either or both ends of the cable.
- (5) Remove the face cover completely and retain in a safe place prior to installation in step (7).

Refer to Figure 2 – Assembly of components

- (6) Unpack and verify the contents of the plastic bag included with the plastic extension ring. Quantity (4) extended length screws and quantity (4) O-rings are included.
- (7) Retrieve the face cover from step (5) and observe the existing screw and O-ring arrangement.
- (8) Remove the existing screw and O-rings. Replace them in same manner with the new extended screws and new O-rings.
- (9) Place the extension ring on the Drive such that the rubber gasket is facing toward the heat sink. The extension ring may appear to have a loose fit. A watertight seal is created after the face cover screws are tightened.
- (10) Re-attach the operator cable removed in step (4) between the Drive face cover and connector CN1 of the installed option card.
- (11) Place the face cover on the extension ring.
- (12) Tighten each of the screws to a torque of **10 lb•in (1.13 N•m)**. This creates a watertight seal.
- (13) Replace the plastic, screw-hole caps.

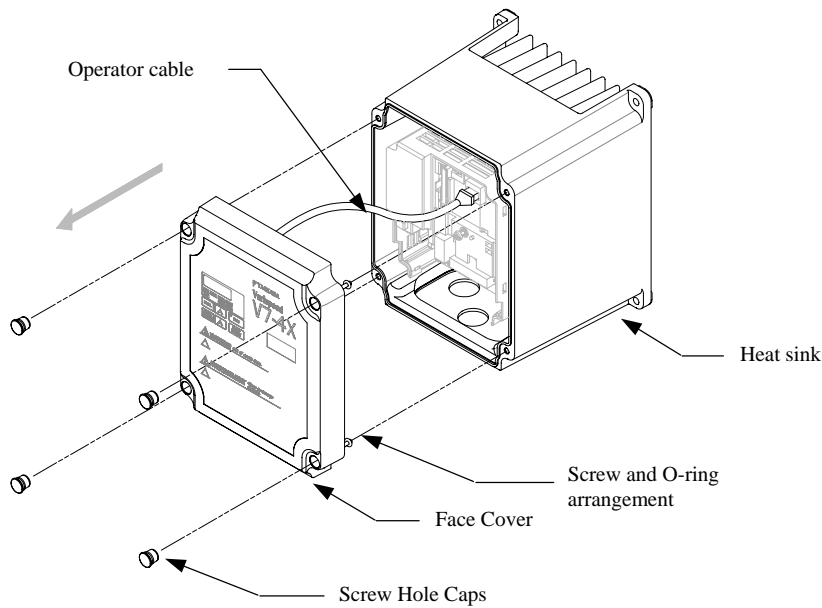

Figure 1. Component Removal

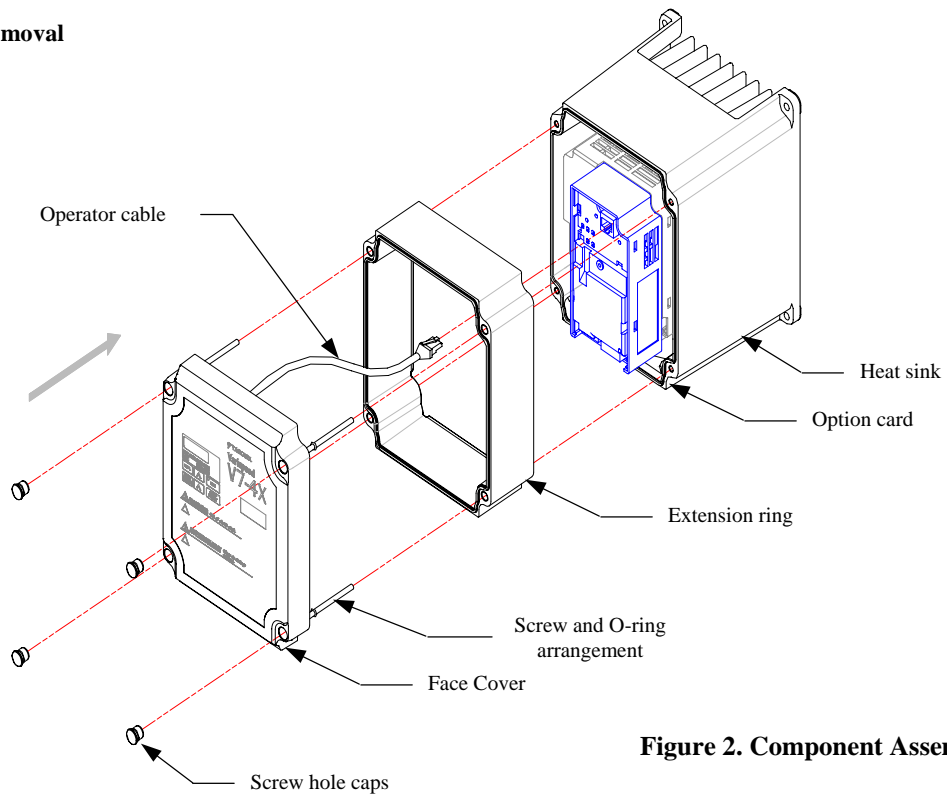
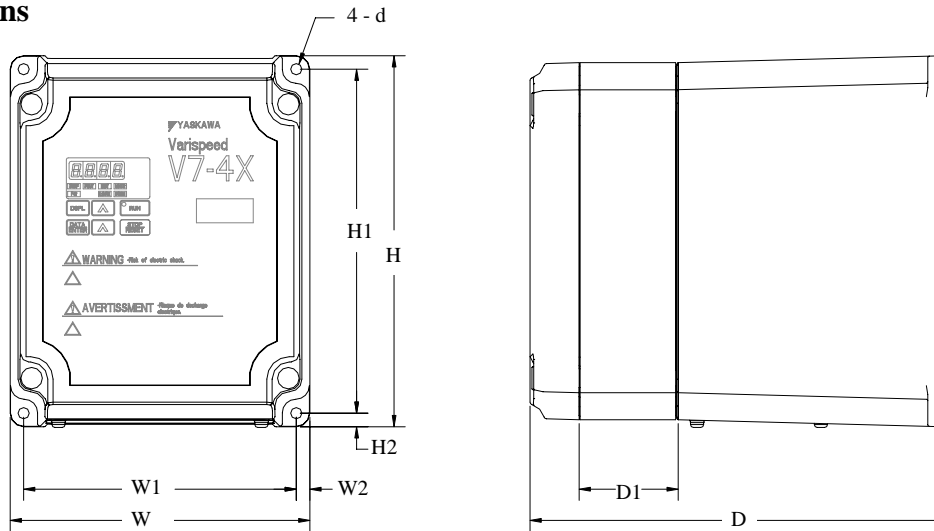

Figure 2. Component Assembly

IMPORTANT

- Never exceed the rated torque specification of **10 lb·in (1.13 N·m)** when tightening the screws.
- Partially insert and torque all 4 screws prior to tightening them to the rated torque specification.
- Tighten the screws in a cross like pattern to protect against damage to the threads.

Dimensions



Dimensions with Option Extension Ring Water and dust tight type (GPD315/V74X)

Voltage Class	Model	Dimensions: Inches (mm)									Weight Lbs (kg)
	CIMR-V7CU □□□□	W	H	D	W1	H1	D1	H2	W2	d.	
200V 3-Phase	20P1	6.10 (155)	7.56 (192)	8.50 (215)	5.55 (141)	7.01 (178)	1.95 (50)	0.28 (7)	0.28 (7)	0.20 (5)	7.77 (3.52)
	20P2	6.10 (155)	7.56 (192)	8.50 (215)	5.55 (141)	7.01 (178)	1.95 (50)	0.28 (7)	0.28 (7)	0.20 (5)	7.77 (3.52)
	20P4	6.10 (155)	7.56 (192)	8.50 (215)	5.55 (141)	7.01 (178)	1.95 (50)	0.28 (7)	0.28 (7)	0.20 (5)	7.99 (3.62)
	20P7	6.10 (155)	7.56 (192)	8.50 (215)	5.55 (141)	7.01 (178)	1.95 (50)	0.28 (7)	0.28 (7)	0.20 (5)	8.21 (3.72)
	21P5	6.69 (170)	10.0 (254)	9.44 (240)	6.22 (158)	9.41 (239)	1.95 (50)	0.24 (6)	0.24 (6)	0.20 (5)	13.03 (5.90)
	22P2	6.69 (170)	10.0 (254)	9.44 (240)	6.22 (158)	9.41 (239)	1.95 (50)	0.24 (6)	0.24 (6)	0.20 (5)	13.25 (6.00)
	23P7	6.69 (170)	10.0 (254)	9.44 (240)	6.22 (158)	9.41 (239)	1.95 (50)	0.24 (6)	0.24 (6)	0.20 (5)	13.69 (6.20)
	25P5	<i>Not Required</i>									
27P5	<i>Not Required</i>										
400V 3-Phase	40P2	6.10 (155)	7.56 (192)	8.50 (215)	5.55 (141)	7.01 (178)	1.95 (50)	0.28 (7)	0.28 (7)	0.20 (5)	8.43 (3.82)
	40P4	6.10 (155)	7.56 (192)	8.50 (215)	5.55 (141)	7.01 (178)	1.95 (50)	0.28 (7)	0.28 (7)	0.20 (5)	8.43 (3.82)
	40P7	6.10 (155)	7.56 (192)	8.50 (215)	5.55 (141)	7.01 (178)	1.95 (50)	0.28 (7)	0.28 (7)	0.20 (5)	8.65 (3.92)
	41P5	6.69 (170)	10.0 (254)	9.44 (240)	6.22 (158)	9.41 (239)	1.95 (50)	0.24 (6)	0.24 (6)	0.20 (5)	13.25 (6.00)
	42P2	6.69 (170)	10.0 (254)	9.44 (240)	6.22 (158)	9.41 (239)	1.95 (50)	0.24 (6)	0.24 (6)	0.20 (5)	13.25 (6.00)
	43P7	6.69 (170)	10.0 (254)	9.44 (240)	6.22 (158)	9.41 (239)	1.95 (50)	0.24 (6)	0.24 (6)	0.20 (5)	13.70 (6.20)
	45P5	<i>Not Required</i>									
	47P5	<i>Not Required</i>									