



iQpump Controller User Manual





iQpump Software Changes

Table 1.1 Modified iQpump Default Settings

Parameter No.	Parameter Name	Original Default Setting PRG: 0033 (VSP130033 and below)	New Default Setting PRG: 0034 (VSP130034 and above)
b5-03	Integral Time Setting PI I Time	5.0 s	3.0 s
b5-12	PI Feedback Reference Missing Detection Selection PFb los Det Sel	0	2
b5-14	PI Feedback Loss Detection Time PFb los Det Time	1.0 s	2.0 s
C1-01	Acceleration Time Accel Time 1	25.0 s	20.0 s
C1-02	Deceleration Time Decel Time 1	25.0 s	10.0 s
L5-01	Number of Auto Restart Attempts Num of Restarts	0	5
L5-03	Maximum Restart Time After Fault Max Restart Time	10.0 s	20.0 s
P1-05	Start Level Delay Time S-Lvl Delay Time	0 s	1 s
P1-06	Minimum Pump Frequency Min Pump Freq	35.0 Hz	40.0 Hz
P2-03	Sleep Delay Time Sleep Delay Time	10 s	5 s
P3-09	Pump 2 Frequency Shutdown Level P2 Freq Shd Lvl	35.0 Hz	40.0 Hz
P3-10	Pump 3 Frequency Shutdown Level P3 Freq Shd Lvl	35.0 Hz	40.0 Hz
P4-05	Thurst Bearing Frequency Thrust Freq	0.00 Hz	30.0 Hz
P5-02	Hand Reference Hand Reference	0.00	40.0 Hz
P9-15	Remove Delay Time Remove Dly Time	5 s	10 s
P9-16	Stabilization Time Stabilization Time	1 s	3 s

■ Miscellaneous Items:

- In the previous software version, the Thrust Bearing Accel Time (P4-04) and Thrust Bearing Decel Time (P4-06) were set based on the time for the drive to reach maximum frequency, just like the standard accel / decel time settings. In the new version, they are set based on the time for the drive to reach the Thrust Frequency (P4-05).
- PID Trim Mode (b5-01 = 3) is deleted. The new b5-01 maximum setting is 2.
- C6-01 is deleted and the drive is internally fixed to setting 2 (Normal Duty 2).
- The C6-02 preset carrier frequency settings are modified. C6-04 and C6-05 are deleted. Certain C6-03 setting ranges are prohibited. Models which previously had a default C6-03 setting of 5.0 kHz, now have a default setting of 5.1 kHz.
- The upper limit of Start Level (P1-04) is decreased from 6000.0 to 999.9
- The MODBUS / Memobus addresses for Monitors U1-96 ~ U1-99 have changed.

Monitor	Original Address (Hex)	New Address (Hex)
U1-96	0726	072A
U1-97	0727	072B
U1-98	0728	072C
U1-99	0729	072D

Table 1.2 Pump Quick Setup

Original Quick Start Menu PRG: 0033 (VSP130033 and below)		New Quick Start Menu PRG: 0034 (VSP130034 and above)	
Parameter No.	Parameter Name	Parameter No.	Parameter Name
b1-01	Frequency Reference Selection Reference Source		REMOVED FROM QUICK START MENU
b1-02	Run Command Selection Run Source		REMOVED FROM QUICK START MENU
b5-12	PI Feedback Reference Missing Detection Selection Fb los Det Sel		REMOVED FROM QUICK START MENU
b5-13	PI Feedback Loss Detection Level Fb los Det Lvl		REMOVED FROM QUICK START MENU
b5-14	PI Feedback Loss Detection Time Fb los Det Time		REMOVED FROM QUICK START MENU
C1-01	Acceleration Time Accel Time 1		REMOVED FROM QUICK START MENU
C1-02	Deceleration Time Decel Time 1		REMOVED FROM QUICK START MENU
		d1-01	Start Level Delay Time S-Lvl Delay Time
E2-01	Motor Rated Current Motor Rated FLA	E2-01	Motor Rated Current Motor Rated FLA
E2-04	Number of Motor Poles Number of Poles	E2-04	Number of Motor Poles Number of Poles
L5-01	Number of Auto Restart Attempts Num of Restarts		REMOVED FROM QUICK START MENU
L5-03	Maximum Restart Time After Fault Max Restart Time		REMOVED FROM QUICK START MENU
P1-02	System Units System Units		REMOVED FROM QUICK START MENU
P1-03	Feedback Device Scaling Fb Dev Scaling	P1-03	Feedback Device Scaling Fb Dev Scaling
P1-04	Start Level Start Level	P1-04	Start Level Start Level
P1-05	Start Level Delay Time S-Lvl Delay Time		REMOVED FROM QUICK START MENU
P1-07	Low Feedback Level Low Fb Lvl		REMOVED FROM QUICK START MENU
P1-08	Low Feedback Level Fault Delay Time Low Lvl FLT Time		REMOVED FROM QUICK START MENU
P1-09	High Feedback Level High Fb Lvl		REMOVED FROM QUICK START MENU
P1-10	High Feedback Level Fault Delay Time Hgh Lvl FLT Time		REMOVED FROM QUICK START MENU
P1-11	Maximum Set-point Difference Max Set-point Diff		REMOVED FROM QUICK START MENU
P1-12	Not Maintaining Set-point Time Not Maint SP Tm		REMOVED FROM QUICK START MENU
P1-14	Prime Loss Level Prime Loss Lvl		REMOVED FROM QUICK START MENU
P2-01	Sleep Level Type Sleep Lvl Type		REMOVED FROM QUICK START MENU
P2-02	Sleep Level Sleep Level		REMOVED FROM QUICK START MENU
P2-03	Start Delay Time Sleep Delay Time		REMOVED FROM QUICK START MENU
P2-10	Maximum Set-point Compensation Max SP Comp		REMOVED FROM QUICK START MENU
P4-01	Pre-charge Level Pre-charge Level		REMOVED FROM QUICK START MENU
P4-02	Pre-charge Frequency Pre-charge Freq		REMOVED FROM QUICK START MENU

Original Quick Start Menu PRG: 0033 (VSP130033 and below)		New Quick Start Menu PRG: 0034 (VSP130034 and above)	
Parameter No.	Parameter Name	Parameter No.	Parameter Name
P4-03	Pre-charge Time Pre-charge Time		REMOVED FROM QUICK START MENU
P4-04	Thrust Bearing Acceleration Time Thrust Acc Time		REMOVED FROM QUICK START MENU
P4-05	Thrust Bearing Frequency Thrust Freq		REMOVED FROM QUICK START MENU
P4-06	Thrust Bearing Deceleration Time Thrust Dec Time		REMOVED FROM QUICK START MENU
P4-07	Feedback Fault Auto Restart Enable Fdback Flt Rstrt		REMOVED FROM QUICK START MENU
P4-08	Protection Fault Auto Restart Enable Prot Flt Rstrt		REMOVED FROM QUICK START MENU
P4-09	Loss of Prime Maximum Restart Time After Fault LOP Max Rstrt T		REMOVED FROM QUICK START MENU
P4-10	Auto Mode Operator Run Power Down Storage AMO PwDn-Storage	P4-10	Auto Mode Operator Run Power Down Storage AMO PwDn-Storage
P5-01	Hand Mode Reference Source Hand Mode Ref		REMOVED FROM QUICK START MENU
P5-02	Hand Reference Hand Reference		REMOVED FROM QUICK START MENU
		P5-04	Hand Key Function Selection Oper HAND Key

THIS PAGE INTENTIONALLY BLANK.

◆ Quick Reference for iQpump (P7U) <0034>

Parameter Number	Factory Setting	User Setting	Parameter Number	Factory Setting	User Setting	Parameter Number	Factory Setting	User Setting	Parameter Number	Factory Setting	User Setting
A1-00	0		C6-03	kVA Dep		H3-08	2		L8-09	1	
A1-01	2					H3-09	B**		L8-10	0	
A1-03	0					H3-10	100.0 %		L8-11	300 s	
A1-04	0					d1-01	0.00		L8-12	45 °C	
A1-05	0					d1-02	0.00		L8-15	1	
b1-01	0					d1-03	0.00		L8-18	1	
b1-02	0					d1-04	0.00		L8-19	20.0 %	
b1-03	0					d1-17	0.00		n1-01	1	
b1-07	0					d2-01	100.0 %		n1-02	1.00	
b1-08	0					d2-02	0.0 %		n3-01	5 %	
b1-11	0 s					d2-03	0.0 %		n3-02	150 %	
b2-01	0.5 Hz					d3-01	0.0 Hz		n3-03	1.0 s	
b2-02	50 %					d3-02	0.0 Hz		n3-04	40 s	
b2-03	0.00 s					d3-03	0.0 Hz		o1-01	6	
b2-04	0.50 s					d3-04	1.0 Hz		o1-02	1	
b2-09	0 %					E1-01	240 V 480 V		o1-05	3	
b3-01	2					E1-03	F		o1-06	1**	
b3-02	120 %		E1-04	60.0 Hz		o1-07	2**				
b3-03	2.0 s		E1-05	230 V 460 V		o1-08	91**				
b3-05	0.2 s		E1-06	60.0 Hz		o2-01	1				
b3-14	1		E1-07	3.0 Hz		o2-02	1				
b4-01	0.0 s		E1-08	17.2 Vac 34.5 Vac		o2-03	0				
b4-02	0.0 s		E1-09	1.5 Hz		o2-04	kVA Dep				
b5-01	1		E1-10	10.3 Vac 20.7 Vac		o2-05	0				
b5-02	2.00		E1-11	0.0 Hz		o2-06	1				
b5-03	3.0 s		E1-12	0.0 Vac		o2-07	0 hr				
b5-04	100.0 %		E1-13	0.0 Vac		o2-08	1				
b5-06	100.00 %		E2-01	kVA Dep		o2-10	0 hr				
b5-07	0.0 %		E2-03	kVA Dep		o2-12	0				
b5-08	0.00 s		E2-04	2		o2-14	0				
b5-10	0		E2-05	kVA Dep		o3-01	0				
b5-12	2		F6-01	1		o3-02	0				
b5-13	0 %		F6-02	0		P1-01	0				
b5-14	2.0 s		F6-03	1		P1-02	1				
b5-17	0.0 s		F6-05	0		P1-03	00145				
b5-32	0.0 Hz		H1-01	24		P1-04	0.0 (system units P1-02)				
b8-01	0		H1-02	14		P1-05	1 s				
b8-04	kVA Dep.		H1-03	3: 2-wire 0: 3-wire		P1-06	40.0 Hz				
b8-05	20 ms					P1-07	0.0 (system units P1-02)				
b8-06	0 %					P1-08	5 s				
C1-01	20.0 s					P1-09	155.0 (system units P1-02)				
C1-02	10.0 s					P1-10	2 s				
C1-03	10.0 s		H1-04	80		P1-11	0.0 (system units P1-02)				
C1-04	10.0 s		H1-05	84		P1-12	60 s				
C1-05	50.0 s		H1-12	0.00 s		P1-13	0.0 (system units P1-02)				
C1-06	50.0 s		H1-13	0.00 s				P1-14	0.0 A		
C1-09	10.0 s		H1-14	0.00 s				P1-15	0		
C1-11	0.0 Hz		H1-15	0.00 s		P1-16	20 s				
C2-01	0.20 s		H1-16	0.00 s		P2-01	0				
C2-02	0.20 s		H2-01	40		P2-02	0.0				
C4-01	1.00		H2-02	41							
C4-02	200 ms		H3-02	100.0 %							
C6-02	kVA Dep		H3-03	0.0 %							
						L8-07	1				
						H4-01	2				
						H4-02	100.0 %				
						H4-03	0.0 %				
						H4-04	8				
						H4-05	50.0 %				
						H4-06	0.0 %				
						H4-07	0				
						H4-08	0				
						H5-01	1F				
						H5-02	3				
						H5-03	0				
						H5-04	3				
						H5-05	1				
						H5-06	5 ms				
						H5-07	1				
						H5-08	0				
						H5-09	2.0 s				
						L1-01	1				
						L1-02	8.0 min				
						L1-03	3				
						L1-04	1				
						L1-05	0.20 s				
						L2-01	2				
						L2-02	kVA Dep				
						L2-03	kVA Dep				
						L2-04	kVA Dep				
						L2-05	Voltage Class Dep				
						L3-01	1				
						L3-02	120 %				
						L3-04	1				
						L3-05	1				
						L3-06	120 %				
						L4-01	0.0 Hz				
						L4-02	2.0 Hz				
						L4-05	0				
						L4-06	0				
						L5-01	5				
						L5-02	0				
						L5-03	20.0 s				
						L6-01	0				
						L6-02	15 %				
						L6-03	10.0 s				
						L8-01	0				
						L8-02	95 °C				
						L8-03	4				
						L8-05	1				
						L8-06	kVA Dep				

Parameter Number	Factory Setting	User Setting	Parameter Number	Factory Setting	User Setting	Parameter Number	Factory Setting	User Setting	Parameter Number	Factory Setting	User Setting
P2-03	5 s		P3-08	0.0 (system units P1-02)		P5-02	40.00 Hz		P8-09	1	
P2-04	0.0 (system units P1-02)					P5-03	0		P8-10	2.00	
P2-05	10 s		P3-09	40.0 Hz		P5-04	1		P8-11	5.0 s	
P2-06	0		P3-10	40.0 Hz		P6-01	0.0 Gpm		P9-02	0	
P2-07	300 s		P3-11	2 s		P6-02	0		P9-03	24 hr	
P2-08	0		P3-12	0.0 (system units P1-02)		P6-03	0		P9-04	0	
P2-09	0.0 (system units P1-02)					P6-04	0.0		P9-05	0	
			P3-13	0.0 Hz		P6-05	10 s		P9-06	55.0 Hz	
P2-10	0.0 (system units P1-02)		P3-14	0.0 (system units P1-02)		P6-06	0.0 min		P9-07	5 s	
						P6-07	1		P9-08	0	
P2-11	0 rpm		P4-01	0.0 (system units P1-02)		P6-08	3.0 min		P9-09	56.0 Hz	
P2-12	15 rpm					P6-09	0.0 gal		P9-10	0.0 (system units P1-02)	
P2-13	5.0 s		P4-02	0.00 Hz		P6-10	0 kgl				
P2-14	5.0 s		P4-03	0.0 min		P6-11	1		P9-11	10 s	
P2-15	1.0 (system units P1-02)		P4-04	1.0 s		P6-12	0.0		P9-12	0	
			P4-05	30.0 Hz		P6-13	10 s		P9-13	40.0 Hz	
P2-16	1.5 (system units P1-02)		P4-06	1.0 s		P6-14	1		P9-14	0.0 (system units P1-02)	
			P4-07	0		P7-01	0				
P2-17	2.0 s		P4-08	0		P7-02	1		P9-15	10 s	
P2-18	2.0 s		P4-09	0.2 min		P7-03	120 %		P9-16	3 s	
P2-19	0		P4-10	0		P7-04	0.3 s		P9-17	0.0 (system units P1-02)	
P2-20	0.0		P4-11	0.2 min		P7-05	25.00 Hz				
P2-21	0.0		P4-12	0.00 Hz		P7-06	10 s		P9-18	90.0 %	
P2-22	5.0 s		P4-13	0.0 min		P7-07	10 s		P9-19	0	
P2-23	0.40 %		P4-14	0		P7-08	2.0 s		P9-20	0	
P2-24	10.0 s		P4-15	0		P7-09	2.0 s		P9-21	8	
P2-25	3.0 psi		P4-16	24.0 hr		P7-10	168.0 hr		P9-22	5	
P3-01	0		P4-17	10.0 (system units P1-02)		P7-11	2.0 s		P9-23	16	
P3-02	59.0 Hz					P8-01	0		P9-24	0 s	
P3-03	0.0 (system units P1-02)		P4-18	0.0 min		P8-02	100 psi		P9-25	08 h	
			P4-19	0.0 min		P8-03	20.0 ft		P9-26	4.0 s	
P3-04	2 s		P4-20	0		P8-04	10.0 ft		P9-27	0	
P3-05	0.0 (system units P1-02)		P4-21	1		P8-05	30.0 ft		P9-28	2.0 s	
			P4-22	10 s		P8-06	0.00 Hz		P9-29	2.0 s	
P3-06	5 s		P4-23	0.0 s		P8-07	0.0 ft		T1-02	kVA Dep	
P3-07	0.0 (system units P1-02)		P5-01	1		P8-08	0.1 min		T1-04	kVA Dep	

* Factory Setting changes to “B” when b5-01 = 1.

** Factory Setting changes to “B” when b5-01 = 1 as follows: o1-06 = 1, o1-07 = 38, o1-08 = 24.

Table of Contents

Warnings and Cautions	13
Introduction	15
Physical Installation	17
iQpump Model Number and Enclosure Style	18
Confirmations Upon Delivery	19
Component Names	21
Exterior and Mounting Dimensions	23
Heat Loss Data	27
Checking and Controlling the Installation Site.....	28
Installation Orientation and Clearances	29
Removing and Attaching the Terminal Cover.....	30
Removing/Attaching the Digital Operator and Front Cover.....	31
Electrical Installation	35
Terminal Block Configuration	36
Wiring Main Circuit Terminals.....	37
Control Wiring	46
Digital Operator	57
Digital Operator Display	58
Digital Operator Keys	59
Drive Mode Indicators	60
Drive Main Menu	62
Pump Quick Setup Menu (-QUICK-) H	67
Programming Menu (-ADV-).....	68
Parameter Editing Example	70
Start-Up	73
Start-Up	74
iQpump Drive Quick Start-Up Procedures	77
Basic Programming	89
iQpump Drive Basic Programming Parameters	90
Pump Tuning.....	100
Pump Basic.....	128
Pump Protection.....	131
T1 Auto-Tuning	135

Diagnostics & Troubleshooting	137
Fault Detection	138
iQpump Keypad Messages	143
Alarm Detection.....	145
Operator Programming Errors (oPE)	148
Auto-Tuning Faults	149
Digital Operator COPY Function Faults	150
Troubleshooting	151
Main Circuit Test Procedure	155
Drive Date Stamp Information	158
Maintenance.....	159
Periodic Inspection.....	160
Preventive Maintenance.....	161
Heatsink Cooling Fan Replacement.....	162
Removing and Mounting the Terminal Card.....	164
Parameters.....	165
Parameter List.....	166
Monitor List.....	197
Fault Trace List	200
Fault History List	201
Capacity Related Parameters.....	203
Drive Capacity.....	204
Parameters Affected by o2-04	205
Capacity Related Parameter Values	206
Specifications	209
Standard iQpump Drive Specifications.....	210
Communication	213
Using Modbus Communication	214
Modbus Function Code Details	218
Modbus Data Tables	220
Modbus Self-Diagnosis	225
Peripheral Devices	227

Branch Circuit Short Circuit Protection.....	228
Branch Circuit Overload Protection.....	230
Peripheral Devices.....	230
Third Party Serial Communication Converters RS232-RS485 / USB - RS485 Converters.....	231
SCADA Software for iQpump Drive (SW.iQp.01).....	233
iQpump Drive Energy Savings Predictor with Carbon Footprint Calculation Software (SW.ESP.03).....	233
iQpump Drive Harmonics Estimator (SW.HE.04).....	233
Electromagnetic Compatibility.....	235
Electromagnetic Compatibility.....	236
Quick Setup Procedures.....	239
Set-up Procedures Included in this Appendix.....	240
Well Draw Down Function.....	241
Sleep/Sleep Boost Function.....	245
Utility Delayed Start Function.....	247
Start Level Function.....	248
Low City Pressure or Low Suction Inlet Pressure.....	250
Lube Pump Digital Output for Deep Well Irrigation.....	251
iQpump Software Multiplexing Set-up.....	252
First In First Out (FIFO) Description.....	262
Anti-No Flow Simplified Setup.....	263

THIS PAGE IS INTENTIONALLY BLANK



Warnings and Cautions

This Section provides warnings and cautions pertinent to this product, that if not heeded, may result in personal injury, fatality, or equipment damage. Yaskawa is not responsible for consequences of ignoring these instructions.

WARNING

YASKAWA manufactures component parts that can be used in a wide variety of industrial applications. The selection and application of YASKAWA products remain the responsibility of the equipment designer or end user. YASKAWA accepts no responsibility for the way its products are incorporated into the final system design. Under no circumstances should any YASKAWA product be incorporated into any product or design as the exclusive or sole safety control. Without exception, all controls should be designed to detect faults dynamically and fail safely under all circumstances. All products designed to incorporate a component part manufactured by YASKAWA must be supplied to the end user with appropriate warnings and instructions as to that part's safe use and operation. Any warnings provided by YASKAWA must be promptly provided to the end user. YASKAWA offers an express warranty only as to the quality of its products in conforming to standards and specifications published in the YASKAWA manual. **NO OTHER WARRANTY, EXPRESS OR IMPLIED, IS OFFERED.** YASKAWA assumes no liability for any personal injury, property damage, losses, or claims arising from misapplication of its products.

WARNING

- Read and understand this manual before installing, operating, or servicing this drive. All warnings, cautions, and instructions must be followed. All activity must be performed by qualified personnel. The iQpump drive must be installed according to this manual and local codes.
- Do not connect or disconnect wiring while the power is on. Do not remove covers or touch circuit boards while the power is on. Do not remove or insert the digital operator while power is on.
- Before servicing, disconnect all power to the equipment. The internal capacitor remains charged even after the power supply is turned off. Status indicator LEDs and Digital Operator display will be extinguished when the DC bus voltage is below 50 Vdc. To prevent electric shock, wait at least five minutes after all indicators are OFF and measure DC bus voltage level to confirm safe level.
- Do not perform a withstand voltage test on any part of the unit. This equipment uses sensitive devices and may be damaged by high voltage.
- The iQpump drive is not suitable for circuits capable of delivering more than 100,000 RMS symmetrical amperes. Install adequate branch short circuit protection per applicable codes. Refer to the specification. Failure to do so may result in equipment damage and / or personal injury.
- Do not connect unapproved LC or RC interference suppression filters, capacitors, or overvoltage protection devices to the output of the drive. These devices may generate peak currents that exceed iQpump drive specifications.
- To avoid unnecessary fault displays caused by contactors or output switches placed between iQpump drive and motor, auxiliary contacts must be properly integrated into the control logic circuit.
- YASKAWA is not responsible for any modification of the product made by the user; doing so will void the warranty. This product must not be modified.
- Verify that the rated voltage of the iQpump drive matches the voltage of the incoming power supply before applying power.
- To meet CE directives, proper line filters and proper installation are required.
- Some drawings in this manual may be shown with protective covers or shields removed, to describe details. These must be replaced before operation.
- Observe electrostatic discharge procedures when handling circuit cards to prevent ESD damage.
- The equipment may start unexpectedly upon application of power. Clear all personnel from the drive, motor, and machine area before applying power. Secure covers, couplings, shaft keys, and machine loads before energizing the drive.
- Please do not connect or operate any equipment with visible damage or missing parts. The operating company is responsible for any injuries or equipment damage resulting from failure to heed the warnings in this manual.

◆ **Intended Use**

Drives are intended for installation in electrical systems or machinery.

For use in the European Union, the installation in machinery and systems must conform to the following product standards of the Low Voltage Directive:

- EN 50178, 1997-10, Equipping of Power Systems with Electronic Devices
- EN 60201-1, 1997-12 Machine Safety and Equipping with Electrical Devices
- Part 1: General Requirements (IEC 60204-1:1997)
- EN 61010, 1997-11 Safety Requirements for Information Technology Equipment
- (IEC 950:1991 + A1:1992 + A2:1993 + A3:1995 + A4:1996, modified)

◆ **Other**

The iQpump (P7U) drive is suitable for use on a circuit capable of delivering not more than 100,000 RMS symmetrical amperes, 240 Vac maximum (240 V Class) and 480 Vac maximum (480 V Class).



Introduction

This Section describes the applicability of the Manual.

The iQpump (P7U) is a Pulse Width Modulated Drive for 3-Phase AC induction motors. This type of drive is also known as an Adjustable Frequency Drive, Variable Frequency Drive, AC Drive, AFD, ASD, VFD, and Inverter.

The iQpump (P7U) is a variable torque AC drive, designed specifically for Simplex and Multiplex pumping applications. The pump applications include Booster Systems, Submersible Deep Well, Fluid Storage Tanks, Metering Pumps, Commercial and Residential Irrigation Systems.

The iQpump (P7U) sets a new benchmark for size, cost, performance, ease-of-use benefits, comprehensive pump and motor protection features, and quality. The iQpump (P7U) includes numerous built-in features such as H/O/A Operation, Selectable Pump Control Engineering Units, PI Control, Pump Basic Control, Pump Protection, Multi-Pump Control (Lead / Lag), and Pump Messaging Terminology.

The LCD keypad / operator is equipped with Hand / Off / Auto functions, copy feature, and 5 lines of display with 16 characters per line.

Built-in PI and pump specific functions and parameters allow the operator to setup specific control values for a wide range of applications. The iQpump (P7U) will optimize the pump performance by automatically adjusting the pump controller based on operating conditions of the pump; such as, process variable changes and pump protection requirements. The P Group programming parameters are dedicated for pumping applications and provide for ease of setup.

The iQpump (P7U) drive offers energy savings by controlling the flow rate and the number of operating pumps on the system. The iQpump (P7U) can be configured using the most popular system control configurations including Simplex, Duplex, and Triplex pumps systems. The iQpump (P7U) is the master controller with the ability to add additional pumps on-line by controlling the digital I/O to each individual motor starter.

The iQpump (P7U) has an optional feature to replace the motors starters with additional drives for a more precise pump control system.

This manual is applicable to the iQpump (P7U) Drives defined by models CIMR-P7U□-107. This manual is subject to change as product improvements occur. The latest version of the manual can be obtained from the Yaskawa. The date shown on the rear cover is changed when revisions are made.

This manual may describe trademarked equipment, which is the property of other companies. These trademarks are the property of the registered owner companies and may include the following:

- Modbus[®], trademark of Schneider Automation, Inc.

Other Documents and Manuals are available to support special use or installation of this product. These documents may be provided with the product or upon request. Contact Yaskawa Electric America, Inc. as required. Documents may include the following:

- TM.iQp.07 Programming Manual
- TM.iQp.11 Modbus Manual
- PumpScada Software and Manual included on CD ROM with product
- Option Instructions included on CD ROM with product

◆ Conventions Used in this Manual

■ Software Versions

Yaskawa recognizes the need to continuously improve product quality. This iQpump drive may receive feature enhancements in the form of software or hardware changes in the future, and new functions may be added to the drive. When a new feature or function is added, the **software version** <####> will be placed next to the feature or function.

EXAMPLE:

A1-00 Language Selection

Setting	Description
0	English (<i>factory default</i>)
1	Japanese
2	Deutsche <0034>
3	Francais <0034>
4	Italiano <0034>
5	Espanol <0034>
6	Portugues <0034>

The example above shows that settings 2, 3, 4, 5, and 6 are added to parameter A1-00 for drive software version PRG: <0034>.

MODEL: CIMR-P7U2018	SPEC: 20181E
INPUT: AC3PH 200-240V 50/60Hz HD:84A ND:89A	
OUTPUT:AC3PH 0-240V 0-400Hz HD:71A 27kVA ND:74.8A 29kVA	
O/N:	MASS: 11kg
S/N: 1W9911234560123	PRG: 0034 ← DRIVE SOFTWARE VERSION
FILE NO: E131457 TYPE 1 ENCLOSURE IP20	

Figure 1. Namplate with PRG software number

The “PRG:” number on the drive nameplate reflects the software version. The software version normally increases to a higher number with newer versions.



Physical Installation

This chapter describes the requirements for receiving and installing the iQpump drive.

1.1 iQpump Model Number and Enclosure Style	18
1.2 Confirmations Upon Delivery	19
1.3 Component Names	21
1.4 Exterior and Mounting Dimensions	23
1.5 Heat Loss Data	27
1.6 Checking and Controlling the Installation Site	28
1.7 Installation Orientation and Clearances	29
1.8 Removing and Attaching the Terminal Cover	30
1.9 Removing / Attaching the Digital Operator and Front Cover . . .	31

1.1 iQpump Model Number and Enclosure Style

Table 1.1 iQpump Model Numbers and Enclosure Style

Input Voltage 3-Phase	iQpump Model-Number CIMR-P7U□-107	Enclosure Style	Rated Output Current	Nominal Hp
208-240 Vac	20P4	NEMA Type 1 (IP20)	3.6	0.5 / 0.75
	20P7	NEMA Type 1 (IP20)	4.6	1
	21P5	NEMA Type 1 (IP20)	7.8	1.5 / 2
	22P2	NEMA Type 1 (IP20)	10.8	3
	23P7	NEMA Type 1 (IP20)	16.8	5
	25P5	NEMA Type 1 (IP20)	23.0	7.5
	27P5	NEMA Type 1 (IP20)	31.0	7.5 / 10
	2011	NEMA Type 1 (IP20)	46.2	15
	2015	NEMA Type 1 (IP20)	59.4	20
	2018	NEMA Type 1 (IP20)	74.8	25
208-230 Vac	2022	NEMA Type 1 (IP20)	88.0	30
	2030	NEMA Type 1 (IP20)	115.0	40
	2037	Open Chassis (IP00)	162.0	50 / 60
	2045	Open Chassis (IP00)	192.0	60 / 75
	2055	Open Chassis (IP00)	215.0	75
	2075	Open Chassis (IP00)	312.0	100 / 125
480 Vac	2090	Open Chassis (IP00)	360.0	125 / 150
	2110	Open Chassis (IP00)	415.0	150
	40P4	NEMA Type 1 (IP20)	1.8	0.5 / 0.75
	40P7	NEMA Type 1 (IP20)	2.1	1
	41P5	NEMA Type 1 (IP20)	3.7	1.5 / 2
	42P2	NEMA Type 1 (IP20)	5.3	3
	43P7	NEMA Type 1 (IP20)	7.6	5
	45P5	NEMA Type 1 (IP20)	12.5	7.5
	47P5	NEMA Type 1 (IP20)	17.0	10
	49P0	NEMA Type 1 (IP20)	21.0	15
	4011	NEMA Type 1 (IP20)	27.0	20
	4015	NEMA Type 1 (IP20)	34.0	25
	4018	NEMA Type 1 (IP20)	40.0	30
	4024	NEMA Type 1 (IP20)	52.0	40
	4030	NEMA Type 1 (IP20)	67.2	50
	4037	NEMA Type 1 (IP20)	77.0	60
	4045	NEMA Type 1 (IP20)	96.0	75
	4055	NEMA Type 1 (IP20)	125.0	100
	4075	Open Chassis (IP00)	156.0	125
	4090	Open Chassis (IP00)	180.0	150
4110	Open Chassis (IP00)	240.0	200	
4160	Open Chassis (IP00)	304.0	250	
4185	Open Chassis (IP00)	414.0	300 / 350	
4220	Open Chassis (IP00)	515.0	400 / 450	
4300	Open Chassis (IP00)	675.0	500+	

1.2 Confirmations Upon Delivery

◆ Receiving Checks

Check the following items as soon as the iQpump drive is received.

Table 1.2 Receiving Checks

Item	Method
Has the correct iQpump drive model been delivered?	Check the model number on the nameplate on the right side of the iQpump drive. Reconcile with packing slip and/or order information.
Is the iQpump drive damaged in any way?	Inspect the entire exterior of the iQpump drive to see if there are any dents, scratches or other damage resulting from shipping.
Are any screws or other components loose?	Use a screwdriver or other tool to check for tightness.

If there are any irregularities in the above items, contact the shipping company, the distributor or representative who sold the iQpump drive, or a Yaskawa office immediately.

The iQpump drive is thoroughly tested at the factory. Any damages or shortages evident when the equipment is received must be reported immediately to the commercial carrier that transported the material. Shipping damage is not covered by the Yaskawa warranty. After unpacking and inspecting for damage, verify that internal wire connections have not come loose during shipment by spot checking wire terminations with a screwdriver or the appropriate tool.

iQpump drive storage must be in a clean and dry location. Maintain the factory packaging and provide covering as needed to protect the iQpump from construction site dirt, water, debris and traffic prior to and during construction.

◆ Nameplate Information

A nameplate is attached to the right side of each iQpump drive. The following nameplate is an example for a standard iQpump drive.

■ Normal P7

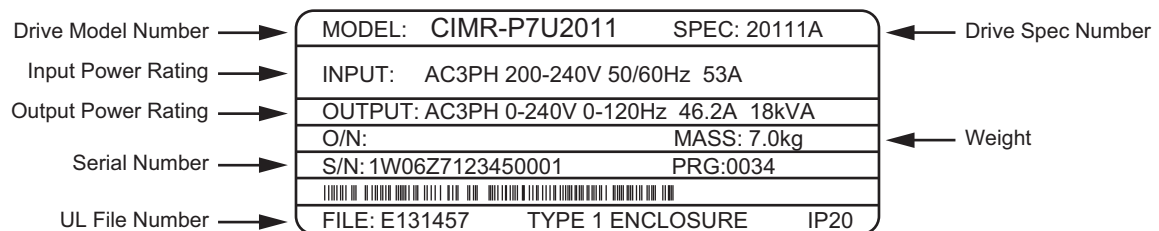

■ P7 iQpump

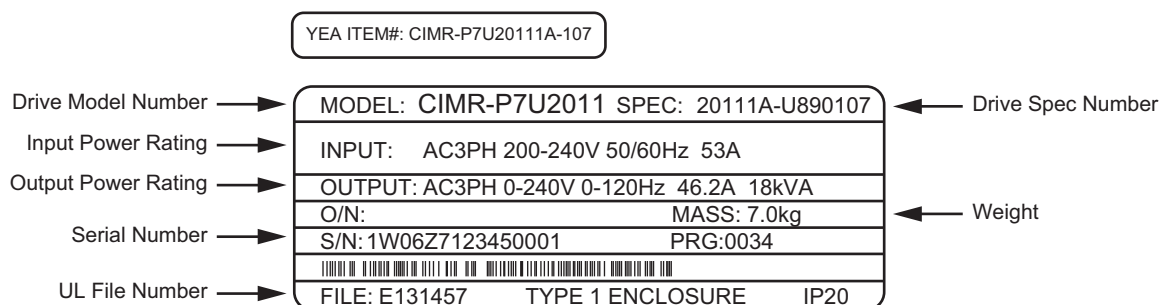

Note: The iQpump Drive Model Number and iQpump Drive Spec. Number are required to completely identify an iQpump Drive.

Figure 1.1 iQpump (P7U) Drive Nameplate

◆ Drive Model Numbers

The model number on the nameplate indicates the design specification, voltage, and rating of the iQpump drive in alphanumeric codes.

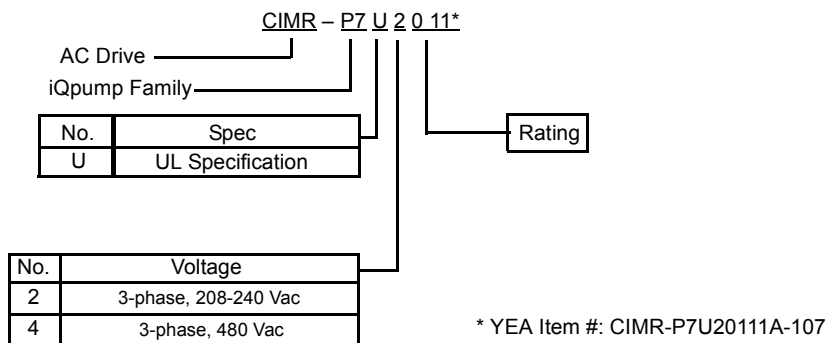

Figure 1.2 iQpump Drive Model Number Structure

◆ Drive Enclosure and Revision Code

The iQpump drive SPEC number on the nameplate indicates the voltage, iQpump drive rating, enclosure type, and the revision code of the iQpump drive in alphanumeric codes.

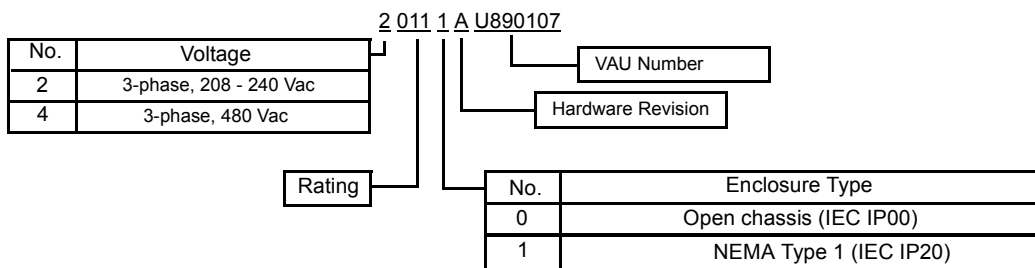

Figure 1.3 SPEC Number Structure



Open Chassis Type (IEC IP00)

Protected so that parts of the human body cannot reach electrically charged parts from the front when the iQpump drive is mounted in a control panel, also called (protected chassis).



NEMA Type 1 (IEC IP20)

The iQpump drive is shielded from the exterior, and can thus be mounted to the interior wall of a building (not necessarily enclosed in a control panel). The protective structure conforms to the standards of NEMA Type 1 in the USA. All protective covers (Fig 1.4) must be installed to conform with IEC IP20 and NEMA Type 1 requirements

1.3 Component Names

◆ Models CIMR-P7U20P4 through 2018 (25 HP @ 208 V / 240 V) and 40P4 through 4018 (30 HP @ 480 V)

The external appearance, component names, and terminal arrangement of the iQpump drive are shown in [Figure 1.4](#) and [Figure 1.5](#).

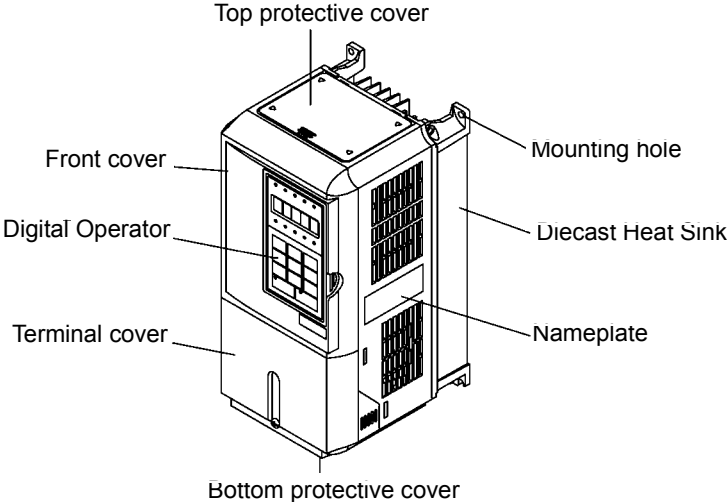

Figure 1.4 iQpump Drive Appearance

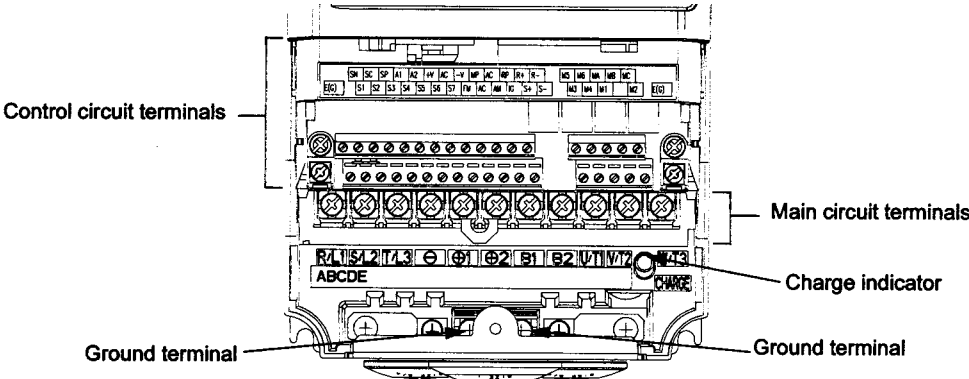

Figure 1.5 Terminal Arrangement (Terminal Cover Removed)

1.3 Component Names

◆ Models CIMR-P7U2022 through 2110 (30 HP and above @ 208 V / 240 V) and 4030 through 4300 (40 HP and above @ 480 V)

The external appearance, component names, and terminal arrangement of the iQpump drive are shown in *Figure 1.6* and *Figure 1.7*.

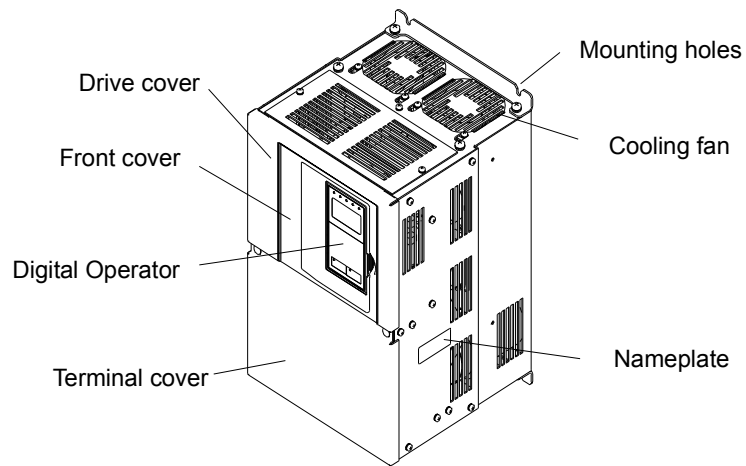

Figure 1.6 iQpump Drive Appearance

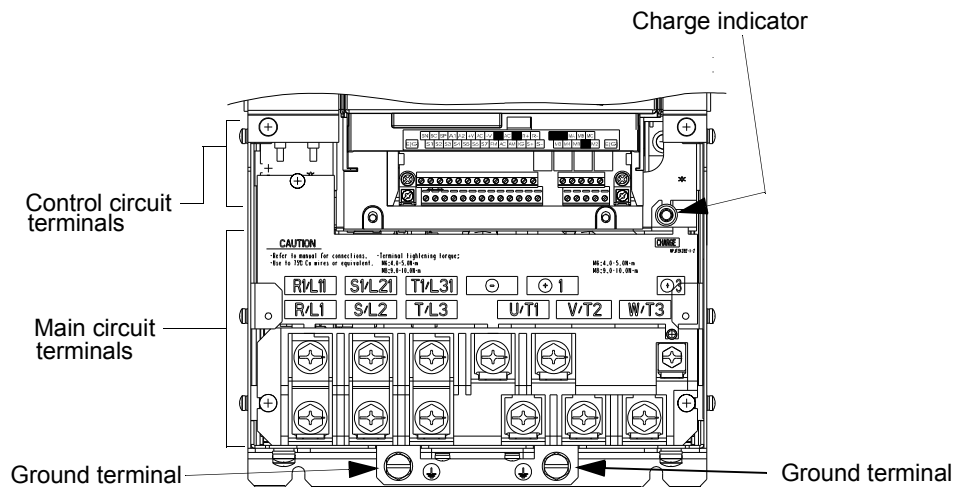

Figure 1.7 Terminal Arrangement (Terminal Cover Removed)

1.4 Exterior and Mounting Dimensions

Dimensions: iQpump (P7U) (NEMA 1) 208 V / 240 V (3.6–74.8 AMPS) 480 V (1.8–40.0 AMPS)

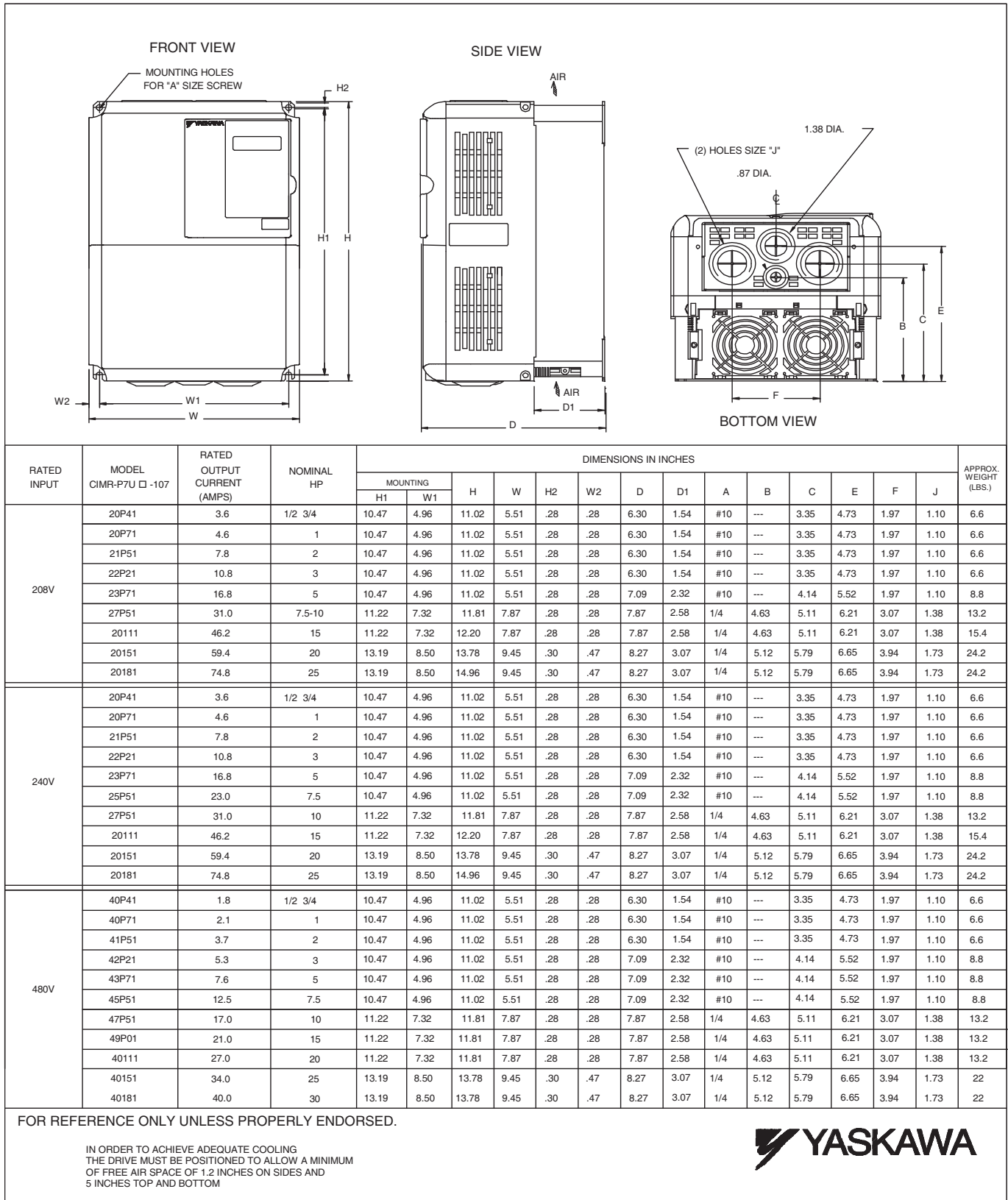
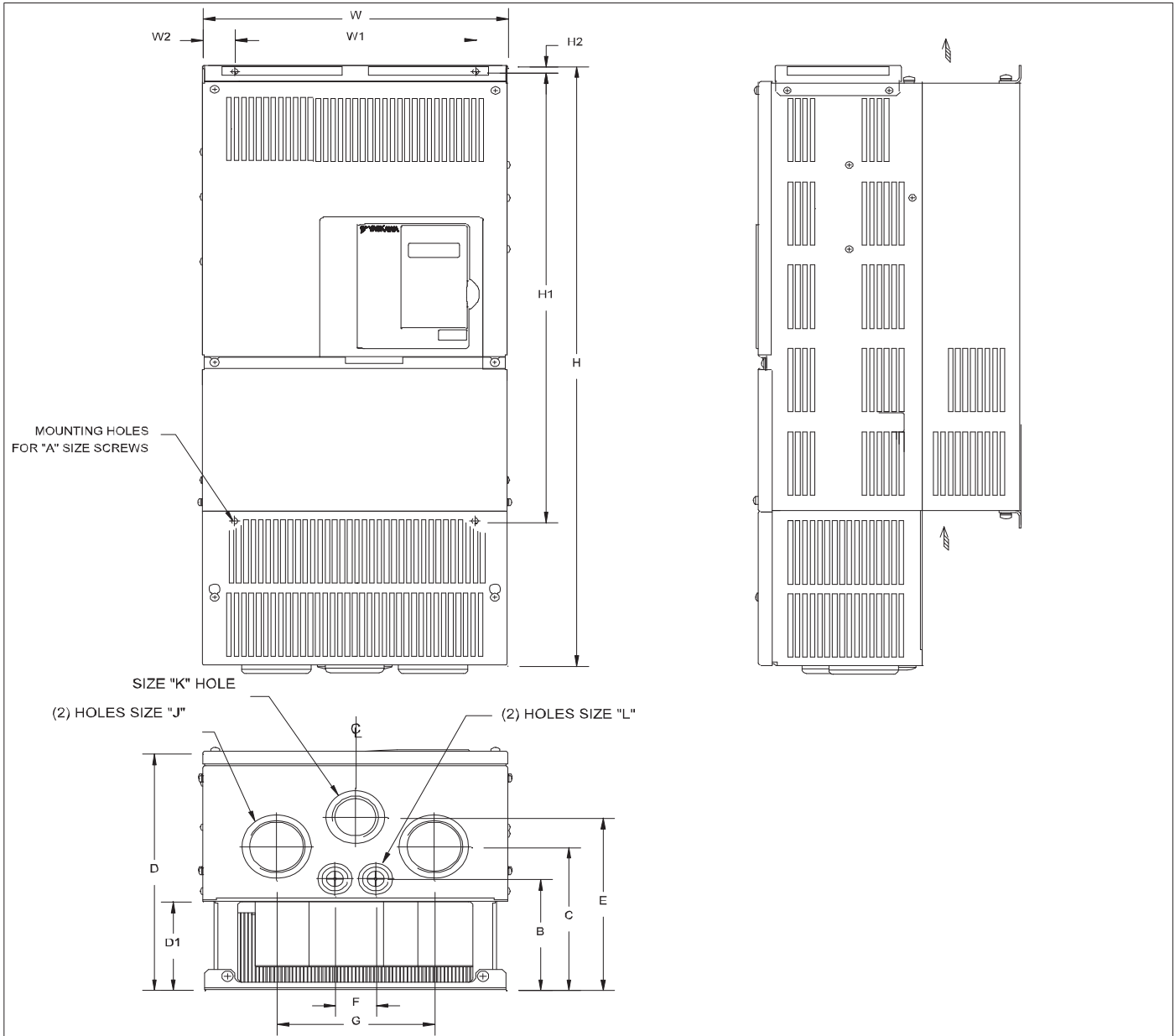

Figure 1.8 Exterior and Mounting Dimensions

1.4 Exterior and Mounting Dimensions

Dimensions: iQpump (P7U) (NEMA 1) 208 V / 240 V (88.0–115 AMPS) 480 V (52.0–125 AMPS)



RATED INPUT	MODEL CIMR-P7U	RATED OUTPUT CURRENT (AMPS)	NOM. HP	DIMENSIONS IN INCHES																	APPROX. WEIGHT (LBS.)
				MOUNTING		H	W	H2	W2	D	D1	A	B	C	E	F	G	J	K	L	
				H1	W1																
208V	20221	88.0	30	15.16	7.68	21.06	10.00	.30	1.16	10.24	3.94	1/4	4.98	6.50	7.87	1.73	5.91	2.44	1.97	1.10	53
	20301	115	40	17.13	8.66	24.21	10.98	.30	1.16	10.24	3.94	1/4	4.98	6.50	7.87	1.73	5.91	2.44	1.97	1.10	59
240V	20221	88.0	30	15.16	7.68	21.06	10.00	.30	1.16	10.24	3.94	1/4	4.98	6.50	7.87	1.73	5.91	2.44	1.97	1.10	53
	20301	115	40	17.13	8.66	24.21	10.98	.30	1.16	10.24	3.94	1/4	4.98	6.50	7.87	1.73	5.91	2.44	1.97	1.10	59
480V	40241	52.0	40	17.13	8.66	21.06	10.98	.30	1.16	10.24	3.94	1/4	4.98	6.50	7.87	1.73	5.91	1.97	1.97	1.10	53
	40301	67.2	50	17.13	8.66	21.06	10.98	.30	1.16	10.24	3.94	1/4	4.98	6.50	7.87	1.73	5.91	1.97	1.97	1.10	53
	40371	77.0	60	21.06	10.24	25.00	12.95	.30	1.36	11.22	4.13	1/4	5.18	6.69	8.07	1.73	6.69	1.97	1.97	1.10	88
	40451	96.0	75	21.06	10.24	28.15	12.95	.30	1.36	11.22	4.13	1/4	5.18	6.69	8.07	1.73	6.69	2.44	1.97	1.10	88
	40551	125	100	21.06	10.24	28.15	12.95	.30	1.36	11.22	4.13	1/4	5.18	6.69	8.07	1.73	6.69	2.44	1.97	1.10	88

FOR REFERENCE ONLY UNLESS PROPERLY ENDORSED.

IN ORDER TO ACHIEVE ADEQUATE COOLING
THE DRIVE MUST BE POSITIONED TO ALLOW A MINIMUM
OF FREE AIR SPACE OF 1.2 INCHES ON SIDES AND
5 INCHES TOP AND BOTTOM



Figure 1.9 Exterior and Mounting Dimensions

Dimensions: iQpump (P7U) (Protected Chassis) 208–230 V (162–415 AMPS) 480 V (156–304 AMPS)

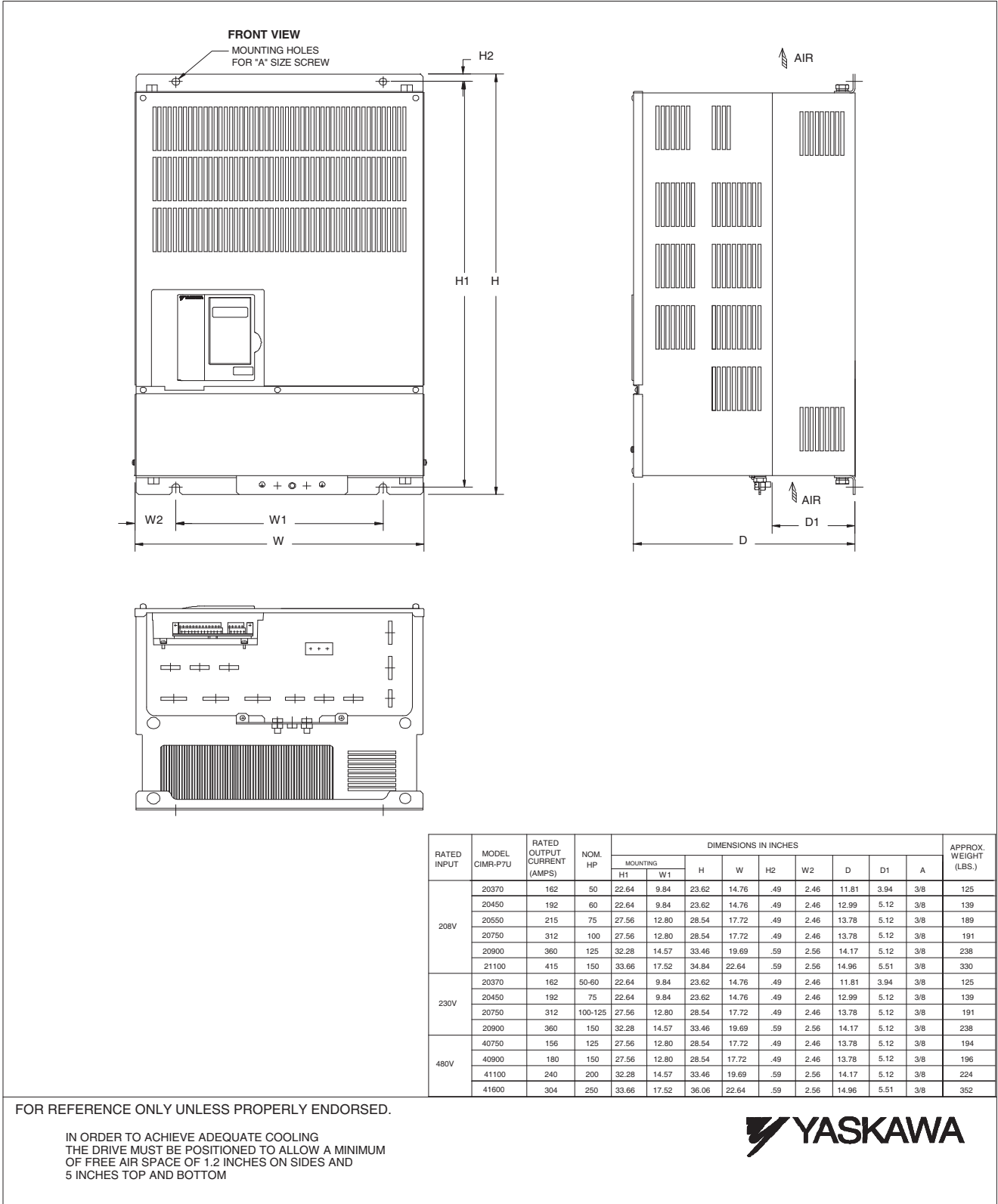
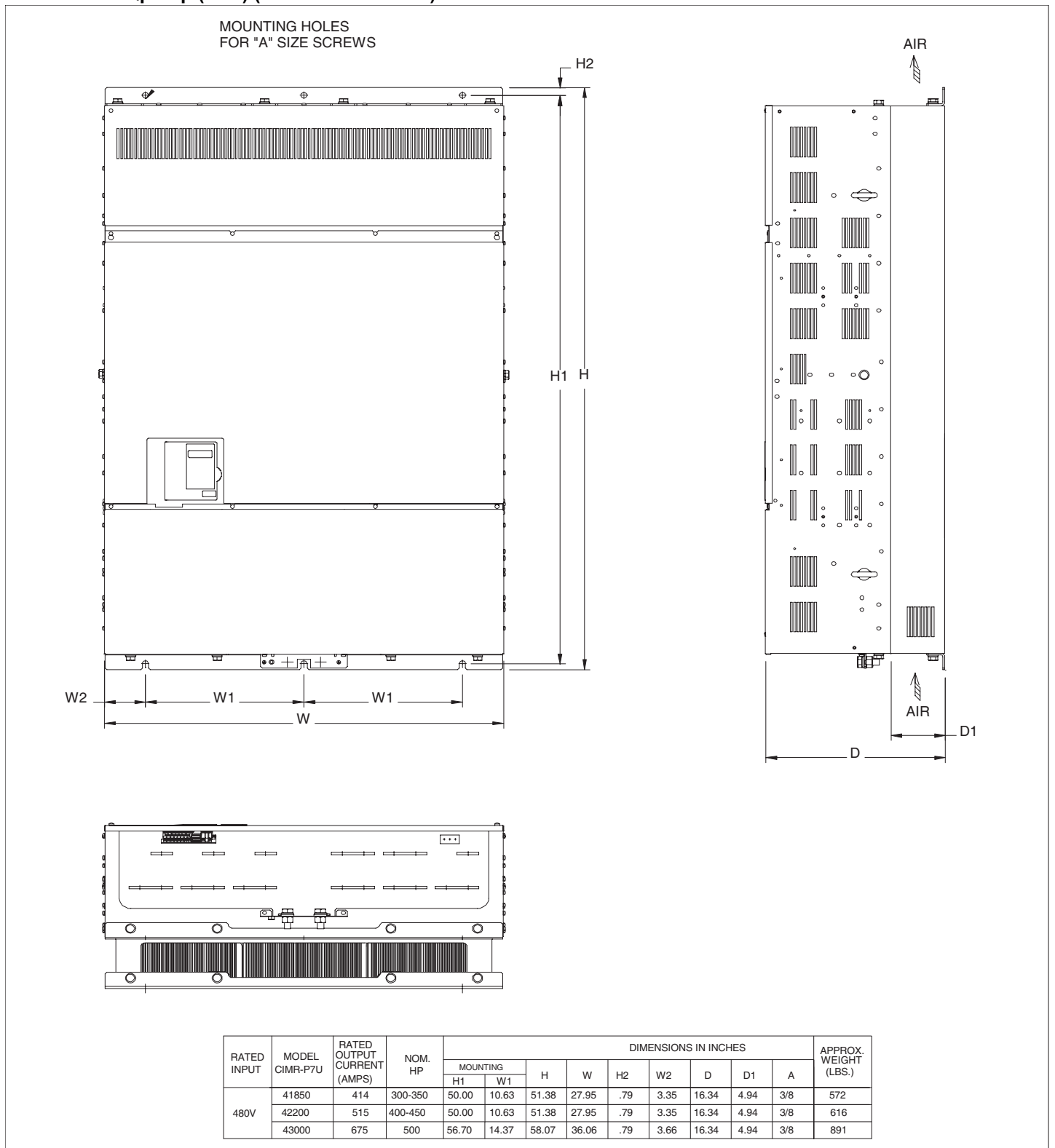

Figure 1.10 Exterior and Mounting Dimensions

1.4 Exterior and Mounting Dimensions

Dimensions: iQpump (P7U) (Protected Chassis)



FOR REFERENCE ONLY UNLESS PROPERLY ENDORSED.

IN ORDER TO ACHIEVE ADEQUATE COOLING
THE DRIVE MUST BE POSITIONED TO ALLOW A MINIMUM
OF FREE AIR OF 1.2 INCHES ON SIDES AND
5 INCHES TOP AND BOTTOM



Figure 1.11 Exterior and Mounting Dimensions

1.5 Heat Loss Data

Table 1.3 200V Class Heat Loss Data

TYPE CIMR-P7U□-107	Drive (Inverter) Capacity (kVA)	Rated Output Current (A)	Cooling Fin Side (W)	Internal Unit Side (W)	Total Watt Loss (W)	Cooling Method
20P4	1.4	3.6	19	39	58	Self
20P7	1.8	4.6	26	42	68	Self
21P5	3.0	7.8	48	50	98	Self
22P2	4.1	10.8	68	59	127	Self
23P7	6.4	16.8	110	74	184	Fan
25P5	8.8	23	164	84	248	Fan
27P5	12	31	219	113	332	Fan
2011	18	46.2	357	168	524	Fan
2015	23	59.4	416	182	597	Fan
2018	29	74.8	472	208	680	Fan
2022	34	88	583	252	835	Fan
2030	44	115	883	333	1217	Fan
2037	62	162	1010	421	1430	Fan
2045	73	192	1228	499	1727	Fan
2055	82	215	1588	619	2206	Fan
2075	120	312	1956	844	2800	Fan
2090	140	360	2194	964	3157	Fan
2110	160	415	2733	1234	3967	Fan

Table 1.4 400V Class Heat Loss Data

TYPE CIMR-P7U□-107	Drive (Inverter) Capacity (kVA)	Rated Output Current (A)	Cooling Fin Side (W)	Internal Unit Side (W)	Total Watt Loss (W)	Cooling Method
40P4	1.4	1.8	14	39	53	Self
40P7	1.6	2.1	17	41	58	Self
41P5	2.8	3.7	36	48	84	Self
42P2	4.0	5.3	59	56	115	Fan
43P7	5.8	7.6	80	68	140	Fan
44P0	6.6	8.7	90	70	160	Fan
45P5	9.5	12.5	127	81	209	Fan
47P5	13	17	193	114	307	Fan
49P0	16	21	232	158	390	Fan
4011	21	27	232	158	390	Fan
4015	26	34	296	169	465	Fan
4018	30	40	389	201	590	Fan
4022	38	50.4	420	233	653	Fan
4024	40	52	691	297	989	Fan
4030	51	67.2	691	297	989	Fan
4037	59	77	801	332	1133	Fan
4045	73	96	901	386	1287	Fan
4055	95	125	1204	478	1682	Fan
4075	120	156	1285	562	1847	Fan
4090	140	180	1614	673	2287	Fan
4110	180	240	1889	847	2736	Fan
4132	200	260	2388	1005	3393	Fan
4160	230	304	2636	1144	3936	Fan
4185	315	414	2791	1328	3964	Fan
4220	390	515	3797	1712	5509	Fan
4300	510	675	5838	2482	8319	Fan

1.6 Checking and Controlling the Installation Site

Install the iQpump drive as described below and maintain optimum conditions.

WARNING

The iQpump drive heatsink temperature may exceed 158 °F (70 °C). Therefore, mount the iQpump drive to a surface suitable for high temperature.

◆ Installation Site

Locate the iQpump drive as close as possible to the motor. Install the iQpump drive under the following conditions in UL Pollution Degree 1 and 2 environments. This excludes wet locations where surfaces may become conductive due to moisture and contaminant loading.

Table 1.5 Installation Site Specifications

Type	Ambient Operating Temperature	Humidity	Plenum Rated
NEMA Type 1	14 °F to 104 °F (-10 to +40 °C)	95 % RH or less (no condensation)	Yes
Open Chassis	14 °F to 113 °F (-10 to +45 °C)	95 % RH or less (no condensation)	No

Protective covers are attached to the top and bottom of the iQpump drive. It is recommended to remove the protective covers before operating a CIMR-P7U2030 / 4055-107 iQpump drive and smaller in a panel to obtain the 113 °F (45 °C) ambient operating temperature.

Observe the following precautions when installing the iQpump drive:

- in a clean location which is free from oil mist and dust.
- in an environment where metal shavings, oil, water, or other foreign materials will not get into the iQpump drive enclosure.
- in a location free from radioactive materials.
- in a location free from harmful gasses and liquids.
- in a location free from excessive vibration.
- in a location free from chlorides.
- in a location away from direct sunlight.
- on a non-combustible surface.

◆ Controlling the Ambient Temperature

To enhance the reliability of operation, the iQpump drive should be installed in an environment free from extreme temperature variations. If the iQpump drive is installed in an enclosure, use a cooling fan or air conditioner to maintain the internal air temperature below 113 °F (45 °C).

◆ Protecting the iQpump Drive from Foreign Matter

During iQpump drive installation and project construction it is possible to have foreign matter, such as metal shavings or wire clippings, fall inside the iQpump drive. To prevent foreign matter from falling into the iQpump drive, place a temporary cover over the iQpump drive.

Always remove the temporary cover from the iQpump drive before Start-Up. Otherwise, ventilation will be reduced, causing the iQpump drive to overheat.

1.7 Installation Orientation and Clearances

Install the iQpump drive vertically so as not to reduce the cooling efficiency. When installing the iQpump drive, always provide the following installation clearances to allow normal heat dissipation. For 3HP, 208V / 240V (CIMR-P7U22P2-107 and below) or 2HP, 480V (CIMR-P7U41P-107 and below), ensure that the heatsink is against a closed surface to avoid diverting cooling air around the heatsink.

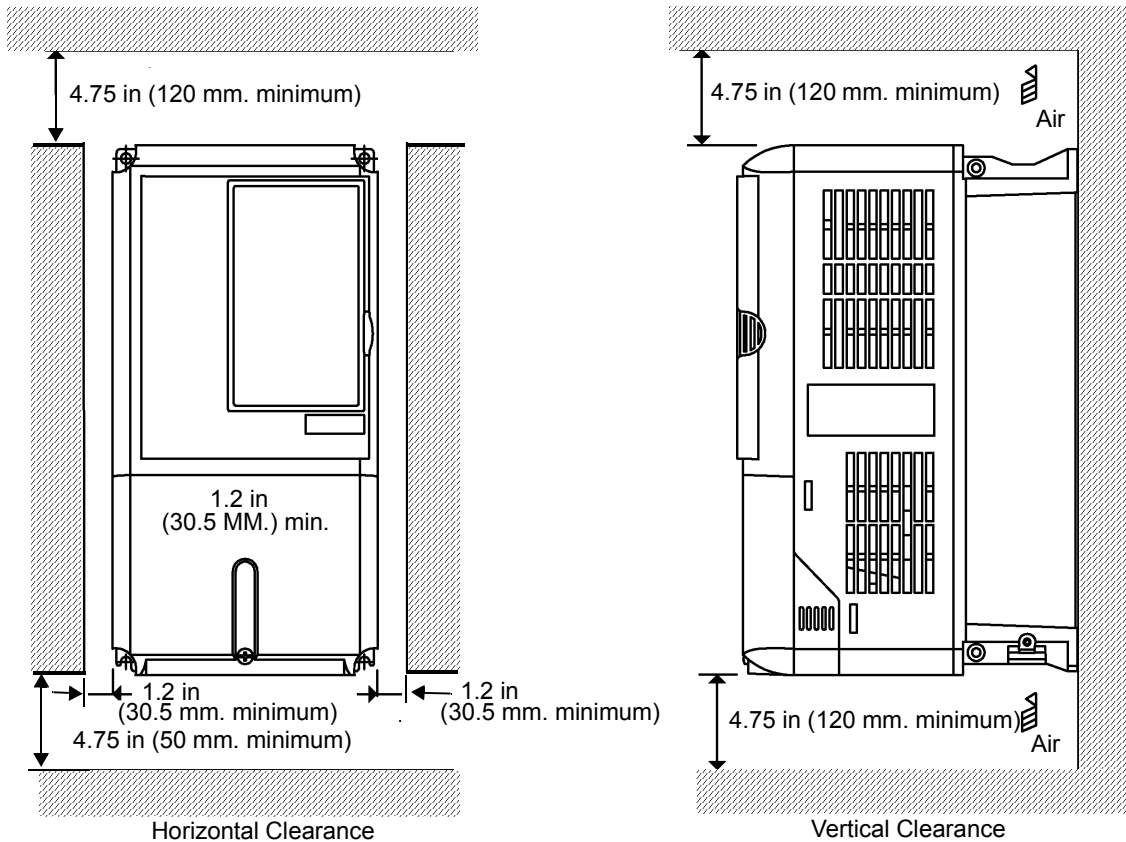

Figure 1.12 iQpump Drive Installation Orientation and Clearance

IMPORTANT

- The same clearance is required horizontally and vertically for both Open Chassis (IP00) and NEMA Type 1 iQpump drives.
- Always remove the top and bottom protection covers before installing a CIMR-P7U2018 / 4018-107 and smaller iQpump drive in a panel. Always provide enough clearance for lifting eye bolts and the main circuit wiring when installing a CIMR-P7U2022 / 4030-107 and larger iQpump drive in a panel.

1.8 Removing and Attaching the Terminal Cover

Remove the terminal cover to connect cables to the control circuit and main circuit terminals.

⚠ WARNING

Prior to removing any protective cover or wiring any part of the iQpump drive, remove all power sources, including main input power and control circuit power. Wait a minimum 5 minutes after power removal, before removing any cover. The charge lamp located within the iQpump drive should be off prior to working inside. Even if the charge lamp is off, one must measure the AC input, output, and DC Bus potential to insure safe levels prior to resuming work. Failure to adhere to this warning may result in personal injury or death.

◆ Removing the Terminal Cover

- **Models CIMR-P7U20P4 through 2018 (0.5 HP to 25 HP @ 208 V / 240 V) and 40P4 through 4018 (0.5 HP to 30 HP @ 480 V)**

Loosen the screw at the bottom of the terminal cover, press in on the sides of the terminal cover in the directions of arrows 1, and then lift up on the terminal in the direction of arrow 2. Refer to [Figure 1.13](#).

- **Models CIMR-P7U2022 through 2110 (30 HP to 150 HP @ 208 V / 240 V) and 4030 through 4300 (40 HP to 500 HP @ 480 V)**

Loosen the screws on the left and right at the top of the terminal cover, pull down the terminal cover in the direction of arrow 1 and then lift up on the terminal cover in the direction of arrow 2. Refer to [Figure 1.14](#).

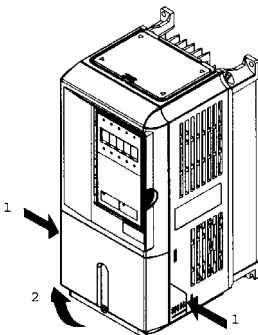

Figure 1.13 Removing the Terminal Cover

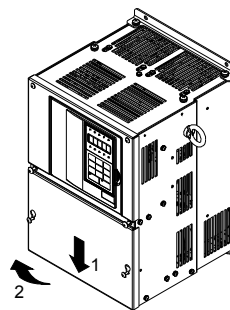

Figure 1.14 Removing the Terminal Cover

◆ Attaching the Terminal Cover

After wiring the terminal block, attach the terminal cover by reversing the removal procedure.

For Models CIMR-P7U2018 / 4018-107 and smaller, insert the tab on the top of the terminal cover into the groove on the iQpump drive and press in on the bottom of the terminal cover until it snaps into place.

For iQpump drives CIMR-P7U2022 / 4030-107 and larger, insert the tab on the top of the terminal cover into the groove on the iQpump drive, and secure the terminal cover by lifting it up toward the top of the iQpump drive.

1.9 Removing/Attaching the Digital Operator and Front Cover

◆ Models CIMR-P7U20P4 through 2018 (0.5 HP to 25 HP @ 208 V / 240 V) and 40P4 through 4018 (0.5 HP to 30 HP @ 480 V)

For Models CIMR-P7U2018 / 4018-107 and smaller, remove the terminal cover and use the following procedures to remove the digital operator and front cover.

■ Removing the Digital Operator

Press on the side of the digital operator in the direction of arrow 1 to unlock, then lift the digital operator in the direction of arrow 2 to remove it as shown in [Figure 1.15](#).

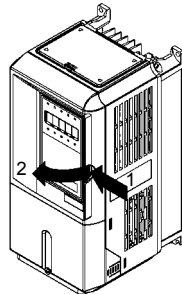

Figure 1.15 Removing the Digital Operator

■ Removing the Front Cover

Press the left and right sides of the front cover in the direction of arrows 1 and lift the bottom of cover in the direction of arrow 2 to remove it as shown in [Figure 1.16](#).

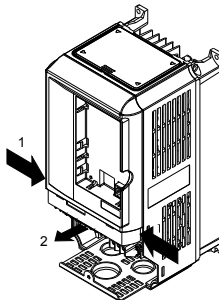

Figure 1.16 Removing the Front Cover

■ Attaching the Front Cover

Mount the front cover to the iQpump drive by performing the steps to remove the front cover in reverse order.

1. Do not mount the front cover with the digital operator attached to the front cover; this may cause the digital operator to malfunction due to imperfect contact.
2. Insert the tab of the upper part of the front cover into the groove of the iQpump drive and press the lower part of the front cover onto the iQpump drive until the front cover snaps into place.

◆ Models CIMR-P7U2022 through 2110 (30 HP to 150 HP @ 208 V / 240 V) and 4030 through 4300 (40 HP to 500 HP @ 480 V)

For Models CIMR-P7U2022 / 4030-107 and larger, remove the terminal cover and then use the following procedures to remove the Digital Operator and front cover.

■ Removing the Digital Operator

Use the same procedure for Models CIMR-P7U2018 / 4018-107 and smaller.

■ Removing the Front Cover

Loosen all screws on the front cover. Lift up at the location labeled 1 at the top of the control circuit terminal card and move in the direction of arrow 2.

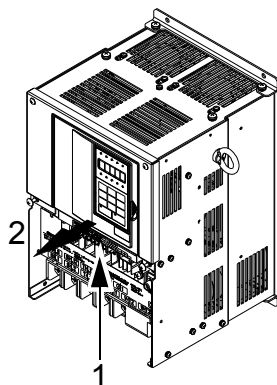

Figure 1.17 Removing the Front Cover

■ Attaching the Front Cover

Attach the front cover by reversing the procedure to remove it.

1. Confirm that the digital operator is not mounted on the front cover. Contact faults can occur if the cover is attached while the digital operator is mounted to it.
2. Insert the tab on the top of the front cover into the slot on the iQpump drive and press in on the cover until it snaps into place on the iQpump drive.

■ Attaching the Digital Operator

After attaching the front cover, mount the digital operator onto the iQpump drive using the following procedure.

1. Hook the digital operator at A (two locations) on the front cover by moving in the direction of arrow 1 as shown in the following illustration.
2. Press the digital operator in the direction of arrow 2 until it snaps in place at B (two locations).

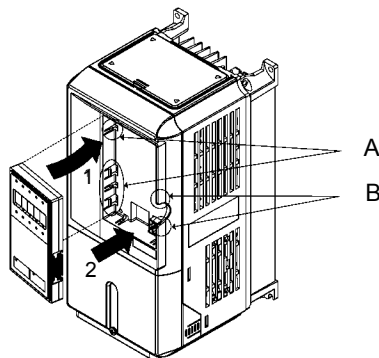

Figure 1.18 Mounting the Digital Operator

IMPORTANT

- Do not remove or attach the Digital Operator or mount or remove the front cover using methods other than those described above, damage to the Digital Operator or iQpump drive may occur.
- Never attach the front cover to the iQpump drive with the Digital Operator attached to the front cover. Damage to the Digital Operator may occur. Always attach the front cover to the iQpump drive first, and then attach the Digital Operator to the front cover.

1.9 Removing/Attaching the Digital Operator and Front Cover

THIS PAGE INTENTIONALLY BLANK.



Electrical Installation

This chapter describes wiring terminals, main circuit terminal connections, main circuit terminal wiring specifications, control circuit terminals, and control circuit wiring specifications.

2.1 Terminal Block Configuration	36
2.2 Wiring Main Circuit Terminals	37
2.3 Control Wiring	46

2.1 Terminal Block Configuration

The wiring terminals are shown in *Figure 2.1*.

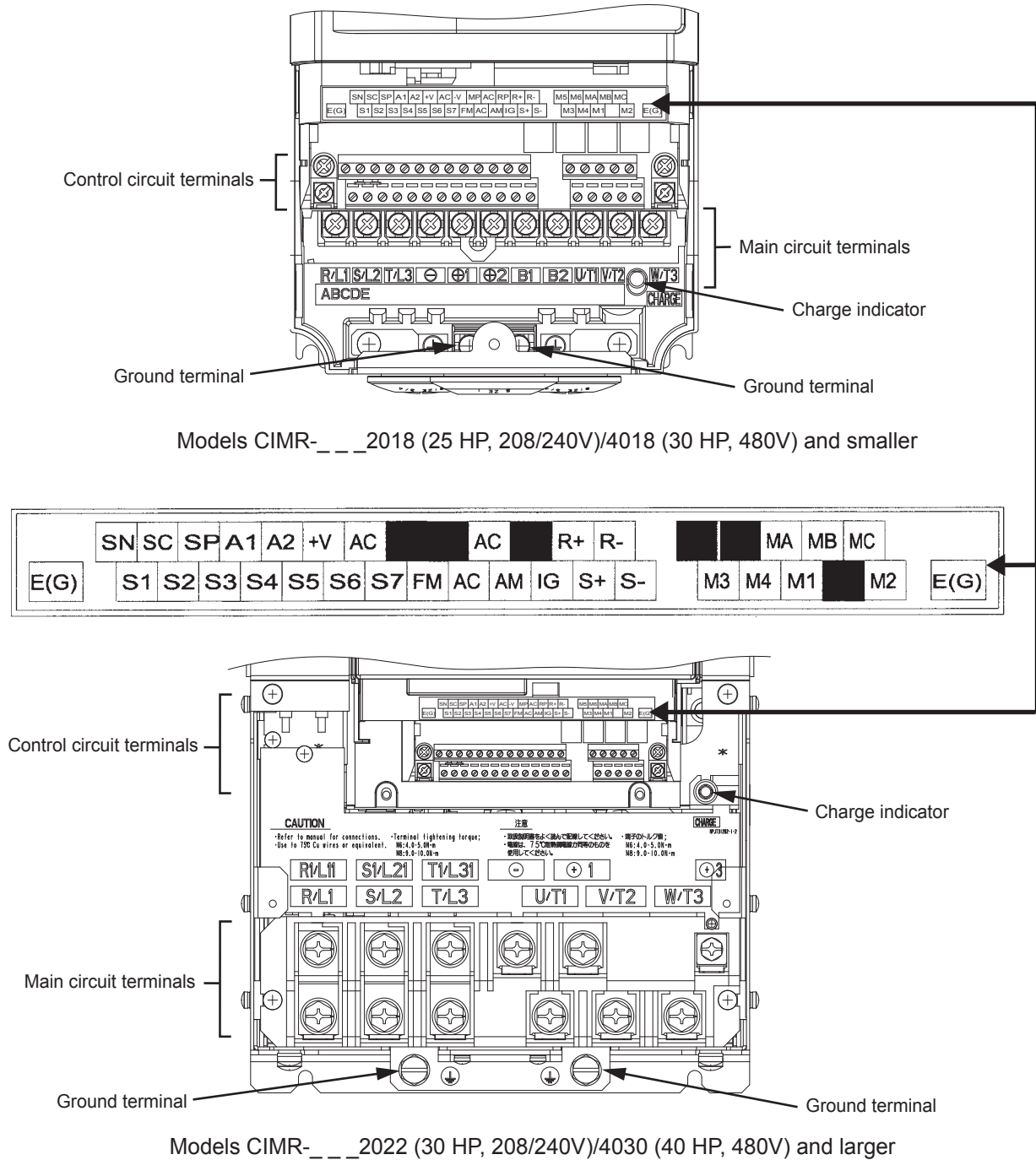

Figure 2.1 iQpump Drive Terminal Configuration

2.2 Wiring Main Circuit Terminals

◆ Applicable Wire Sizes and Closed-Loop Connectors

Select the appropriate wires and crimp terminals from [Table 2.1](#) to [Table 2.2](#).

Table 2.1 208-240 Vac Wire Sizes and Connector Specifications

Drive Model CIMR-P7U□-107	Nominal HP	Terminal Symbol	Terminal Screws	Clamping Torque lb. in. (N·m)	Recommended Wire Size AWG (mm ²)	Wire Type
20P4	0.5 / 0.75	R/L1, S/L2, T/L3, ⊖, ⊕1, ⊕2, B1, B2, U/T1, V/T2, W/T3	M4	13.3 (1.5)	14 (2.1)	600 Vac UL Approved vinyl-sheathed or equivalent
		⊖				
20P7	2	R/L1, S/L2, T/L3, ⊖, ⊕1, ⊕2, B1, B2, U/T1, V/T2, W/T3	M4	13.3 (1.5)	14 (2.1)	
		⊖				
21P5	1.5 / 2	R/L1, S/L2, T/L3, ⊖, ⊕1, ⊕2, B1, B2, U/T1, V/T2, W/T3	M4	13.3 (1.5)	14 (2.1)	
		⊖				
22P2	3	R/L1, S/L2, T/L3, ⊖, ⊕1, ⊕2, B1, B2, U/T1, V/T2, W/T3	M4	13.3 (1.5)	12 (3.3)	
		⊖				
23P7	5	R/L1, S/L2, T/L3, ⊖, ⊕1, ⊕2, B1, B2, U/T1, V/T2, W/T3	M4	13.3 (1.5)	10 (5.3)	
		⊖				
25P5	7.5	R/L1, S/L2, T/L3, ⊖, ⊕1, ⊕2, B1, B2, U/T1, V/T2, W/T3	M4	13.3 (1.5)	10 (5.3)	
		⊖				
27P5	10	R/L1, S/L2, T/L3, ⊖, ⊕1, ⊕2, B1, B2, U/T1, V/T2, W/T3	M5	22.1 (2.5)	8 (8)	
		⊖				
2011	15	R/L1, S/L2, T/L3, ⊖, ⊕1, ⊕2, B1, B2, U/T1, V/T2, W/T3	M5	22.1 (2.5)	6 (13.3)	
		⊖				
2015	20	R/L1, S/L2, T/L3, ⊖, ⊕1, ⊕2, U/T1, V/T2, W/T3	M6	44.3 (5.0)	4 (21.2)	
		B1, B2	M5	22.1 (2.5)	6 (13.3)	
		⊖	M6	44.3 (5.0)	6 (13.3)	
2018	25	R/L1, S/L2, T/L3, ⊖, ⊕1, ⊕2, U/T1, V/T2, W/T3	M8	88.5 (10.0)	2 (33.6)	
		B1, B2	M5	22.1 (2.5)	6 (13.3)	
		⊖	M6	44.3 (5.0)	4 (21.2)	
2022	30	R/L1, S/L2, T/L3, ⊖, ⊕1, U/T1, V/T2, W/T3, R1/L11, S1/L21, T1/L31	M8	88.5 (10.0)	1 (42.4)	
		⊕3	M6	45.1 (5.1)	4 (21.2)	
		⊖	M8	88.5 (10.0)	4 (21.2)	
2030	40	R/L1, S/L2, T/L3, ⊖, ⊕1 U/T1, V/T2, W/T3, R1/L11, S1/L21, T1/L31	M8	88.5 (10.0)	1/0 (53.5)	
		⊕3	M6	45.1 (5.1)	4 (21.2)	
		⊖	M8	88.5 (10.0)	2 (38)	

2.2 Wiring Main Circuit Terminals

Drive Model CIMR-P7U□-107	Nominal HP	Terminal Symbol	Terminal Screws	Clamping Torque lb. in. (N·m)	Recommended Wire Size AWG (mm ²)	Wire Type
2037	50	R/L1, S/L2, T/L3, ⊖, ⊕1 U/T1, V/T2, W/T3, R1/L11, S1/L21, T1/L31	M10	199 (22.5)	4/0 (100)	600 Vac UL Approved vinyl-sheathed or equivalent
		⊕3	M8	88.5 (10.0)	4 (22)	
		⊖	M10	203.6 (23)	2/0 (67.4)	
		r/l1, s/l2	M4	12.4 (1.4)	14 (2.1)	
2045	60	R/L1, S/L2, T/L3, ⊖, ⊕1 U/T1, V/T2, W/T3, R1/L11, S1/L21, T1/L31	M10	199 (22.5)	300 (152)	
		⊕3	M8	88.5 (10.0)	4 (21.2)	
		⊖	M10	199 (22.5)	3/0 (85)	
		r/l1, s/l2	M4	12.4 (1.4)	14 (2.1)	
2055	75	R/L1, S/L2, T/L3, ⊖, ⊕1	M12	347 (39.2)	1/0 X 2P (53.5 X 2P)	
		U/T1, V/T2, W/T3, R1/L11, S1/L21, T1/L31	M10	199 (22.5)	1/0 X 2P (53.5 X 2P)	
		⊕3	M8	88.5 (10.0)	2/0 (67.4)	
		⊖	M10	199 (22.5)	4/0 (107.2)	
		r/l1, s/l2	M4	12.4 (1.4)	14 (2.1)	
2075	75 / 100	R/L1, S/L2, T/L3, ⊖, ⊕1	M12	347 (39.2)	4/0 X 2P (80 X 2P)	
		U/T1, V/T2, W/T3, R1/L11, S1/L21, T1/L31	M10	199 (22.5)	3/0 X 2P (85 X 2P)	
		⊕3	M8	88.5 (10.0)	2/0 (67.4)	
		⊖	M10	199 (22.5)	2/0 X 2P (67.4 X 2P)	
		r/l1, s/l2	M4	12.4 (1.4)	14 (2.1)	
2090	125	R/L1, S/L2, T/L3, ⊖, ⊕1	M12	347 (39.2)	250 x2P (127 x2P)	
		U/T1, V/T2, W/T3, R1/L11, S1/L21, T1/L31	M12	347 (39.2)	4/0 X 2P (107.2 X 2P)	
		⊕3	M8	88.5 (10.0)	2/0 (67.4)	
		⊖	M12	347 (39.2)	2/0 X 2P (67.4 X 2P)	
		r/l1, s/l2	M4	12.4 (1.4)	14 (2.1)	
2110	150	R/L1, S/L2, T/L3, ⊖, ⊕1	M12	347 (39.2)	300 X 2P (152 X 2P)	
		U/T1, V/T2, W/T3, R1/L11, S1/L21, T1/L31	M12	347 (39.2)	300 X 2P 152 X 2P	
		⊕3	M8	88.5 (10.0)	2/0 (67.4)	
		⊖	M12	347 (39.2)	4/0 X 2P (107.2 X 2P)	
		r/l1, s/l2	M4	12.4 (1.4)	16 (1.25)	

* Use 75 °C copper wire or equivalent

Table 2.2 480 Vac Wire Sizes and Connector Specifications

Drive Model CIMR-P7U□-107	Nominal HP	Terminal Symbol	Terminal Screws	Clamping Torque lb. in. (N·m)	Recommended Wire Size AWG (mm ²)	Wire Type
40P4	0.5 / 0.75	R/L1, S/L2, T/L3, ⊖, ⊕1, ⊕2, B1, B2, U/T1, V/T2, W/T3	M4	13.3 (1.5)	14 (2.1)	600 Vac UL Approved vinyl-sheathed or equivalent
		⊕				
40P7	1	R/L1, S/L2, T/L3, ⊖, ⊕1, ⊕2, B1, B2, U/T1, V/T2, W/T3	M4	13.3 (1.5)	14 (2.1)	
		⊕				
41P5	1.5 / 2	R/L1, S/L2, T/L3, ⊖, ⊕1, ⊕2, B1, B2, U/T1, V/T2, W/T3	M4	13.3 (1.5)	14 (2.1)	
		⊕				
42P2	3	R/L1, S/L2, T/L3, ⊖, ⊕1, ⊕2, B1, B2, U/T1, V/T2, W/T3	M4	13.3 (1.5)	14 (2)	
		⊕				
43P7	5	R/L1, S/L2, T/L3, ⊖, ⊕1, ⊕2, B1, B2, U/T1, V/T2, W/T3	M4	13.3 (1.5)	14 (2.1)	
		⊕			14 (2.1)	
45P5	7.5	R/L1, S/L2, T/L3, ⊖, ⊕1, ⊕2, B1, B2, U/T1, V/T2, W/T3	M4	13.3 (1.5)	12 (3.5)	
		⊕			14 (2)	
47P5	10	R/L1, S/L2, T/L3, ⊖, ⊕1, ⊕2, B1, B2, U/T1, V/T2, W/T3	M4	13.3 (1.5)	10 (5.5)	
		⊕			12 (3.5)	
49P0 / 4011	15 / 20	R/L1, S/L2, T/L3, ⊖, ⊕1, ⊕2, B1, B2, U/T1, V/T2, W/T3	M5	22.1 (2.5)	8 (8)	
		⊕			10 (5.5)	
4015	25	R/L1, S/L2, T/L3, ⊖, ⊕1, ⊕2, B1, B2, U/T1, V/T2, W/T3	M5	22.1 (2.5)	8 (8)	
		⊕				
4018	30	R/L1, S/L2, T/L3, ⊖, ⊕1, ⊕3, U/T1, V/T2, W/T3,	M6	44.3 (5.0)	6 (13.3)	
		B1, B2	M5	21.1 (2.5)	8 (8)	
		⊕	M6	44.3 (5.0)	6 (13.3)	
4024 / 4030	40 / 50	R/L1, S/L2, T/L3, ⊖, ⊕1, ⊕3, U/T1, V/T2, W/T3, R1/ L11, S1/L21, T1/L31	M6	44.3 (5.0)	3 (26.7)	
		⊕	M8	88.5 (10.0)	6 (13.3)	
4037	60	R/L1, S/L2, T/L3, ⊖, ⊕1, U/T1, V/T2, W/T3, R1/L11, S1/L21, T1/L31	M8	88.5 (10.0)	2 (33.6)	
		⊕3	M6	44.3 (5.0)	4 (21.2)	
		⊕	M8	88.5 (10.0)	4 (21.2)	
4045	75	R/L1, S/L2, T/L3, ⊖, ⊕1, U/T1, V/T2, W/T3, R1/L11, S1/L21, T1/L31	M8	88.5 (10.0)	2 (33.6)	
		⊕3	M6	44.3 (5.0)	4 (21.2)	
		⊕	M8	88.5 (10.0)	4 (21.2)	

2.2 Wiring Main Circuit Terminals

Drive Model CIMR-P7U□-107	Nominal HP	Terminal Symbol	Terminal Screws	Clamping Torque lb. in. (N·m)	Recommended Wire Size AWG (mm ²)	Wire Type
4055	100	R/L1, S/L2, T/L3, ⊖, ⊕1, U/T1, V/T2, W/T3, R1/L11, S1/L21, T1/L31	M8	88.5 (10.0)	2/0 (33.6)	600 Vac UL Approved vinyl-sheathed or equivalent
		⊕3	M6	44.3 (5.0)	4 (21.2)	
		⊖	M8	88.5 (10.0)	1 (42.4)	
4075	125	R/L1, S/L2, T/L3, ⊖, ⊕1	M12	347 (39.2)	4/0 (107.2)	
		U/T1, V/T2, W/T3, R1/L11, S1/L21, T1/L31	M10	199 (22.5)	3/0 (85)	
		⊕3	M8	88.5 (10.0)	4/0 (107.2)	
		⊖	M12	347 (39.2)	1/0 (53.5)	
		r/l1, ⌀200/l2200, ⌀400/l2400	M4	12.4 (1.4)	14 (2.1)	
4090	150	R/L1, S/L2, T/L3, ⊖, ⊕1	M12	347 (39.2)	250 (127)	
		U/T1, V/T2, W/T3, R1/L11, S1/L21, T1/L31	M10	199 (22.5)	4/0 (107.2)	
		⊕3	M8	88.5 (10.0)	4/0 (107.2)	
		⊖	M12	347 (39.2)	2/0 (67.4)	
		r/l1, ⌀200/l2200, ⌀400/l2400	M4	12.4 (1.4)	14 (2.1)	
4110	200	R/L1, S/L2, T/L3, ⊖, ⊕1	M12	347 (39.2)	2/0 X 2P (67.4 X 2P)	
		U/T1, V/T2, W/T3, R1/L11, S1/L21, T1/L31	M12	347 (39.2)	1/0 X 2P (53.5 X 2P)	
		⊕3	M8	88.5 (10.0)	2/0 (67.4)	
		⊖	M12	347 (39.2)	4/0 (107.2)	
		r/l1, ⌀200/l2200, ⌀400/l2400	M4	12.4 (1.4)	14 (2.1)	
4160	250	R/L1, S/L2, T/L3, ⊖, ⊕1	M12	347 (39.2)	4/0 X 2P (107.2 X 2P)	
		U/T1, V/T2, W/T3, R1/L11, S1/L21, T1/L31	M12	347 (39.2)	3/0 X 2P (85 X 2P)	
		⊕3	M8	88.5 (10.0)	2/0 (67.4)	
		⊖	M12	347 (39.2)	1/0 X 2P (53.5 X 2P)	
		r/l1, ⌀200/l2200, ⌀400/l2400	M4	12.4 (1.4)	14 (2.1)	

2.2 Wiring Main Circuit Terminals

Drive Model CIMR-P7U□-107	Nominal HP	Terminal Symbol	Terminal Screws	Clamping Torque lb. in. (N·m)	Recommended Wire Size AWG (mm ²)	Wire Type
4185	300 / 350	R/L1, S/L2, T/L3, ⊖, ⊕1	M8	88.5 (10.0)	300 X 2P (152 X 2P)	600 Vac UL Approved vinyl-sheathed or equivalent
		U/T1, V/T2, W/T3, R1/L11, S1/L21, T1/L33	M8	88.5 (10.0)	300 X 2P (152 X 2P)	
		⊕3	M8	88.5 (10.0)	2/0 (67.4)	
		⊖	M16	867.4 (98.0)	3/0 X 2P (85 X 2P)	
		r/l1, Ⓜ200/ℓ2200, Ⓜ400/ℓ2400	M4	12.4 (1.4)	14 (2.1)	
4220	400 / 450	R/L1, S/L2, T/L3, ⊖, ⊕1	M8	88.5 (10.0)	500 X 2P (253 X 2P)	
		U/T1, V/T2, W/T3, R1/L11, S1/L21, T1/L33	M8	88.5 (10.0)	400 X 2P (203 X 2P)	
		⊕3	M8	88.5 (10.0)	2/0 (67.4)	
		⊖	M16	867.4 (98.0)	250 X 2P (127 X 2P)	
		r/l1, Ⓜ200/ℓ2200, Ⓜ400/ℓ2400	M4	12.4 (1.4)	14 (2.1)	
4300	500+	R/L1, S/L2, T/L3, ⊖, ⊕1	M8	88.5 (10.0)	700 X 2P (355 X 2P)	
		U/T1, V/T2, W/T3, R1/L11, S1/L21, T1/L33	M8	88.5 (10.0)	600 X 2P (304 X 2P)	
		⊕3	M8	88.5 (10.0)	2/0 (67.4)	
		⊖	M8	867.4 (98.0)	400 X 2P (203 X 2P)	
		r/l1, Ⓜ200/ℓ2200, Ⓜ400/ℓ2400	M16	12.4 (1.4)	14 (2.1)	

* Use 75 °C copper wire or equivalent

IMPORTANT	<p>Determine the wire size for the main circuit so that line voltage drop is within 2 % of the rated voltage. Line voltage drop is calculated as follows:</p> <ul style="list-style-type: none"> Line voltage drop (V) = $\sqrt{3}$ x wire resistance (W / km) x wire length (m) x current (A) x 10⁻³
------------------	--

WARNING

Prior to removing any protective cover or wiring any part of the iQpump drive, remove all power sources including main input power and control circuit power. Wait a minimum of 5 minutes after power removal before removing any cover. The charge lamp located within the iQpump drive should be off prior to working inside the iQpump drive. Even if the charge lamp is off, measure the AC input, output, and DC Bus potential to insure safe levels prior to resuming work. Failure to adhere to this warning may result in personal injury or death.

2.2 Wiring Main Circuit Terminals

◆ Main Circuit Terminal Functions

Main circuit terminal functions are summarized according to terminal symbols in [Table 2.3](#). Wire the terminals correctly for the desired purpose.

Table 2.3 Main Circuit Terminal Functions (208-240 Vac and 480 Vac)

Purpose	Terminal Designation	Model: CIMR-P7U□-107	
		208-240 Vac	480 Vac
Main circuit power input	R/L1, S/L2, T/L3	20P4 to 2110	40P4 to 4300
	R1/L11, S1/L21, T1/L31	2022 to 2110	4030 to 4300
Drive outputs	U/T1, V/T2, W/T3	20P4 to 2110	40P4 to 4300
DC power input	⊕1, ⊖	20P4 to 2110	40P4 to 4300
DC reactor connection	⊕1, ⊕2	20P4 to 2018	40P4 to 4018
Ground	⊖	20P4 to 2110	40P4 to 4300

◆ Main Circuit Configurations 208-240 Vac

The 208-240 Vac main circuit configurations of the iQpump drive are shown in [Table 2.4](#).

Table 2.4 iQpump Drive Main Circuit Configurations

208-240 Vac	
<p>CIMR-___20P4 to 2018 (1/2 Hp to 25 Hp)</p>	<p>CIMR-___2022 and 2030 (30 Hp to 40Hp)</p>
<p>CIMR-___2037 to 2110 (50 Hp to 150 Hp)</p>	<p>—</p>

- Note:**
1. Input fuses or molded case circuit breakers are required for proper branch circuit protection for all iQpump drives. Failure to use recommended fuses / circuit breakers (See [Appendix E](#)) may result in damage to the wiring, iQpump drive and/or personal injury.
 2. Control power is supplied internally from the main circuit DC power supply for all iQpump drives.
 3. Consult your Yaskawa representative before using 12-pulse rectification.

2.2 Wiring Main Circuit Terminals

◆ Main Circuit Configurations 480 Vac

The 480 Vac main circuit configurations of the iQpump drive are shown in [Table 2.5](#).

Table 2.5 iQpump Drive Main Circuit Configurations

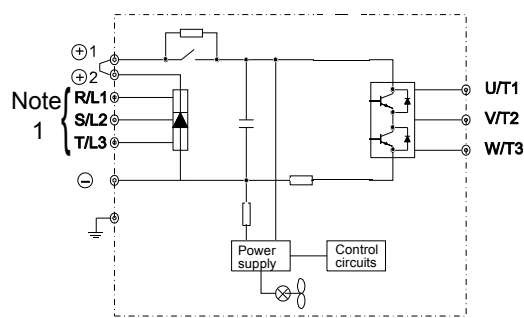
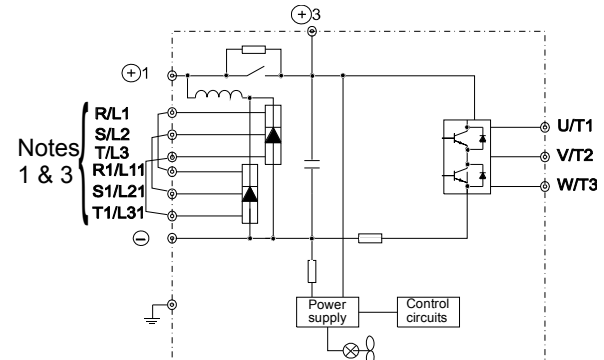
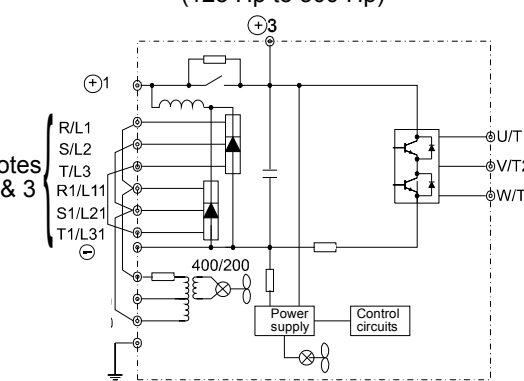
480 Vac	
<p>CIMR-___40P4 to 4018 (1/2 Hp to 30 Hp)</p>  <p>Note 1</p>	<p>CIMR-___4024 to 4055 (40 Hp to 100 Hp)</p>  <p>Notes 1 & 3</p>
<p>CIMR-___4075 to 4160 and CIMR-___4185 to 4300 (125 Hp to 500 Hp)</p>  <p>Notes 1 & 3</p>	<p style="text-align: center;">—</p>
<p>Note: 1. Input fuses or molded case circuit breakers are required for proper branch circuit protection for all iQpump drives. Failure to use recommended fuses / circuit breakers (see Appendix E) may result in damage to the wiring, iQpump drive and/or personal injury.</p> <p>2. Control power is supplied internally from the main circuit DC power supply for all iQpump drives.</p> <p>3. Consult your Yaskawa representative before using 12-pulse rectification.</p>	

■ Cable Length Between iQpump Drive and Motor

The iQpump drive should be installed as close as possible to the motor to minimize the length of load side power cable needed between the iQpump drive and the motor.

If the cable between the iQpump drive and the motor is too long, drive output current will increase as the leakage current from the cable increases, which may affect peripheral devices. Reduce the cable length whenever possible, or adjust the carrier frequency (set in C6-02) as shown in [Table 2.6](#) to prevent problems with peripheral devices.

Run the line-side power cables, load-side power cables and the control wiring in a separate conduit. Careful attention to this recommended design practice will avoid many potential motor and iQpump drive-related problems.

Table 2.6 Motor Cable Length vs. Carrier Frequency (C6-02)

Motor Cable Length	328ft. (100m) maximum	More than 328ft. (100m)
Carrier Frequency	8 kHz maximum	2 kHz maximum

(See the limitations on carrier frequency, based on iQpump drive capacity and model number in [Appendix B](#)).

■ Ground Wiring

Observe the following precautions when connecting the ground wire:

1. 208-240 Vac iQpump drives should have a ground connection with resistance of less than 100 Ω .
2. 480 Vac iQpump drives should have a ground connection with resistance of less than 10 Ω .
3. Do not share the ground wire with other devices, such as motors or large-current electrical equipment.
4. Always use a ground wire that complies with technical standards on electrical equipment and minimize the length of the ground wire. Leakage current flows through the iQpump drive. Therefore, if the distance between the ground rod and the ground terminal is too long, potential on the ground terminal of the iQpump drive will become unstable.
5. When using more than one iQpump drive, be careful not to loop the ground wire. See [Figure 2.2](#).

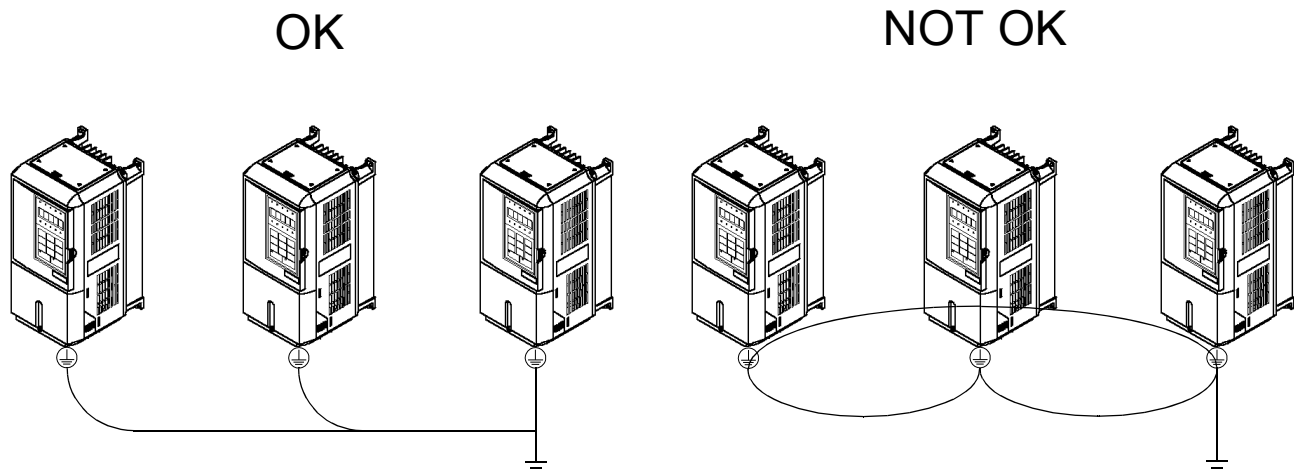

Figure 2.2 Ground Wiring Examples

■ Control Circuit Ground Terminals

The removable iQpump drive control terminal card provides two ground terminals (marked TB3 and TB4) to accept the control wire shield connection. The control wire shield should be connected on this end only, the opposite end should be isolated with electrical tape.

IMPORTANT	• Grounding of the iQpump enclosure and motor is required for proper system operation.
------------------	--

2.3 Control Wiring

◆ Control Circuit Wire Sizes

The auto mode setpoint (speed command) field wiring connection is made to iQpump drive terminals A1 or A2 (signal positive), AC (signal common) and G (shield). Keep this lead length as short as possible to maintain signal quality. Insulated twisted shielded pair wire (2 conductor # 18 ga, Belden 8760 or equivalent) is required. Do not run these wires in the same conduit as other AC power or control wires. The shield must be connected on this end only, stub and isolate the other end. The A2 signal employed is 4 to 20 mA with parameter H3-08 set for 2: 4 - 20 mA. For 0 to 10 Vdc, parameter H3-08 is set for 0: 0 - 10 Vdc and the iQpump control board DIP switch S1-2 must be in the OFF position. (See [Figure 2.4](#)).

For remote operation, keep the length of the control wiring to 50m or less. Separate the control wiring from high-power lines (input power, motor leads or relay sequence circuits) to reduce noise induction from peripheral devices.

When setting speed commands (frequency references) from an external speed potentiometer (and not from the Digital Operator), use shielded twisted-pair wires and ground the shield to terminal E (G), as shown in [Figure 2.3](#). Terminal numbers and wire sizes are shown in [Table 2.7](#).

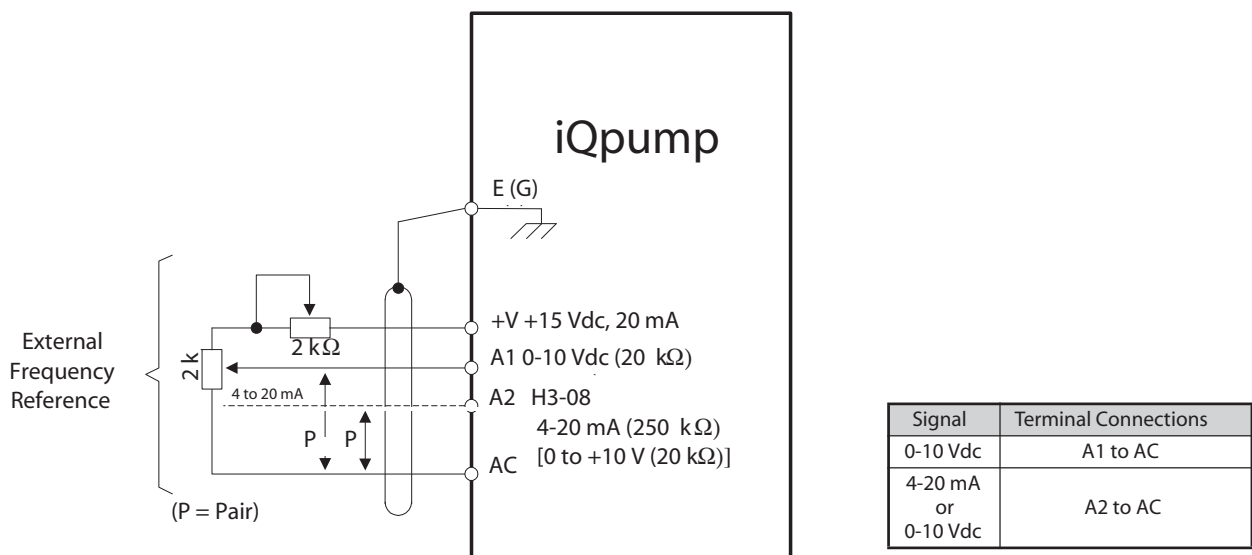

Figure 2.3 Analog Input Terminal Configuration

Table 2.7 Terminal Numbers and Wire Sizes (Same for all iQpump Drives)

Terminals	Terminal Screws	Tightening Torque lb-in (N•m)	Possible Wire Sizes AWG (mm ²)	Recommended Wire Size AWG (mm ²)	Wire Type
S1, S2, S3, S4, S5, S6, S7 SN, SC, SP, +V, A1, A2, AC, MI, M2, M3, M4, MA, MB, MC, FM, AC, AM, R+, R-, S+, S-, IG	Phoenix type *3	4.2 to 5.3 (0.5 to 0.6)	Stranded wire: 26 to 16 (0.14 to 1.5)	18 (0.75)	<ul style="list-style-type: none"> Shielded, twisted-pair wire*1 Shielded, polyethylene-covered, vinyl sheath cable
E (G)	M3.5	7.0 to 8.8 (0.8 to 1.0)	20 to 14 (0.5 to 2*2)	12 (1.25)	

*1. Use shielded twisted-pair cables to input an external speed command.

*2. Yaskawa recommends using straight solderless terminals on digital inputs to simplify wiring and improve reliability.

*3. Yaskawa recommends using a thin-slot screwdriver with a 3.5 mm blade width.

■ Wiring Checks

After all wiring is completed, perform the following checks:

1. Is all wiring correct?
2. Have all wire clippings, screws or other foreign material been removed from the iQpump drive enclosure?
3. Are all terminal screws tight?

◆ Control Circuit Terminal Functions

The factory default functions of the control circuit terminals for 2-wire control are shown in [Table 2.8](#).

Table 2.8 Control Circuit Terminals

Type	No.	Signal Name	Description	Signal Level	
Digital input signals	S1	Forward run / stop command	Forward run when CLOSED; stopped when OPEN.	24 Vdc, 8 mA Photocoupler isolation	
	S2	Not used.	Not used.		
	S3	External fault input	Fault when CLOSED.		Multi-function digital inputs Functions set by H1-01 to H1-05.
	S4	Fault reset	Reset when CLOSED		
	S5	Multi-step SP1	Multi-step SP1 frequency reference when CLOSED.		
	S6	Hand Mode	Hand Mode when CLOSED.		
	S7	Pre-Charge	Pre-Charge function disabled when CLOSED.		
	SN	Digital input common	Refer to Table 2.10 for connection details.		
	SC				
	SP				
Analog input signals	+V	+15 Vdc power supply	+15 Vdc power supply for analog inputs or transmitters	+15 Vdc (Max. current: 20 mA)	
	A1	Analog input or Speed Command	0 to +10 Vdc / 100 %	0 to +10 V (20 kΩ)	
	A2	Multi-function analog input (PI Feedback)	4 ~ 20 mA / 100 % 0 to +10Vdc / 100 % (H3-0)	Function set by H3-09.	4 to 20 mA (250Ω) 0 to +10 V (20 kΩ)
	AC	Analog common	—	—	
	E(G)	Shield wire, optional ground line connection point	—	—	
Digital output signals	M1	Pump 2 Control (N.O. contact)	CLOSED during operation	Multi-function digital output Function set by H2-01.	Dry contacts Contact capacity: 1 A max. at 250 Vac 1 A max. at 30 Vdc
	M2				
	M3	Pump 3 Control (N.O. contact)	CLOSED when local control	Multi-function digital output Function set by H2-02.	
	M4				
	MA	Fault output signal (SPDT)	MA / MC: CLOSED during fault condition MB / MC: OPEN during fault condition		
	MB				
MC					
Analog output signals	FM	Multi-function analog output	(output frequency) 0 to +10 Vdc / 100 % frequency	Multi-function analog monitor 1 Function set by H4-01	0 to +10 Vdc max. ±5 % 2 mA max.
	AC	Analog common	—		
	AM	Multi-function analog output	(output current) 0 to +10 Vdc / 100 % drive rated output current	Multi-function analog monitor 2 Function set by H4-04	
RS-485 / 422	R+	Modbus communication input	For 2-wire RS-485, jumper R+ and S+ and jumper R- and S-.		Differential input, PHC isolation
	R-				
	S+	Modbus communication output			Differential input, PHC isolation
	S-				
IG	Signal common	—	—		

◆ DIP Switch S1

DIP Switch S1 is described in this section. The functions of DIP switch S1 are shown in [Table 2.9](#).

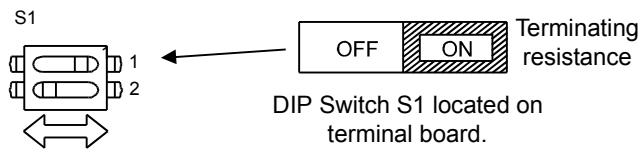

Figure 2.4 DIP Switch S1 Location

Table 2.9 DIP Switch S1

Name	Function	Setting
S1-1	RS-485 and RS-422 terminating resistance	OFF: No terminating resistance (<i>factory default</i>) ON: Terminating resistance of 110 Ω
S1-2	Input method for analog input A2	OFF: 0-10 Vdc (internal resistance: 20 kΩ) ON: 4 ~ 20 mA (internal resistance: 250 Ω) (<i>factory default</i>)

◆ Shunt Connector CN15

The shunt connector CN15 is described in this section. The shunt connector along with parameters H4-07 and H4-08 select the signal range of the analog output terminals FM and AM.

Shunt connector CN15 is only available when the optional Terminal Card with the 4-20 mA Analog Output Monitor is installed (Model No. ETC618120). See [Chapter 7 Maintenance](#), for installation of the optional Terminal Card.

The function of various shunt connector CN15 configurations is shown in [Table 2.10](#).

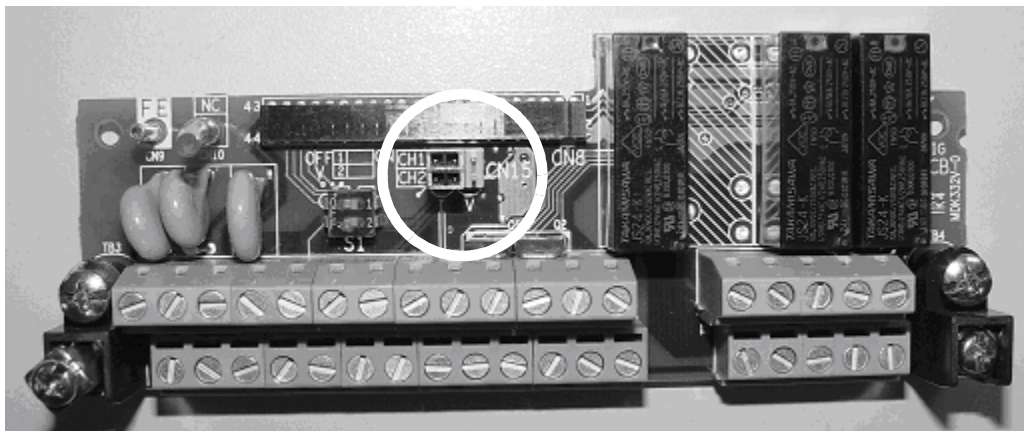

Figure 2.5 Shunt Connector CN15 Location

Table 2.10 Shunt Connector CN15 Configuration Options

CN15	Analog Output Monitor Configurations
	Voltage Output (0 - 10 Vdc) for terminals FM-AC (CH1) and AM-AC (CH2)
	Current Output (4 ~ 20 mA) for terminals FM-AC (CH1) and AM-AC (CH2)
	Voltage Output (0 - 10 Vdc) for terminals FM-AC (CH1) Current Output (4 ~ 20 mA) for terminals AM-AC (CH2)
	Current Output (4 ~ 20 mA) for terminals FM-AC (CH1) Voltage Output (0 - 10 Vdc) for terminals AM-AC (CH2)

The software configuration for the analog output monitor signal type is listed below:

Parameter No.	Addr. Hex	Parameter Name Digital Operator Display	Description	Setting Range	Factory Setting	Menu Location
H4-07	0423	Terminal FM Signal Level Selection AO Level Select1	0: 0 - 10 Vdc 2: 4 ~ 20 mA*	0 or 2	0	Programming
H4-08	0424	Terminal AM Signal Level Selection AO Level Select2	0: 0 - 10 Vdc 2: 4 ~ 20 mA* * An analog output of 4 ~ 20 mA cannot be used with the standard terminal board. Therefore an optional terminal board (with shunt connector CN15) is needed.	0 or 2	0	Programming

◆ Sinking/Sourcing Mode

The input terminal logic can be switched between sinking mode (0 V common) and sourcing mode (+24 V common) by using the terminals SN, SC, and SP. An external power supply can also be connected, providing more freedom in signal input methods.

Table 2.11 Sinking/Sourcing Mode and Input Signals

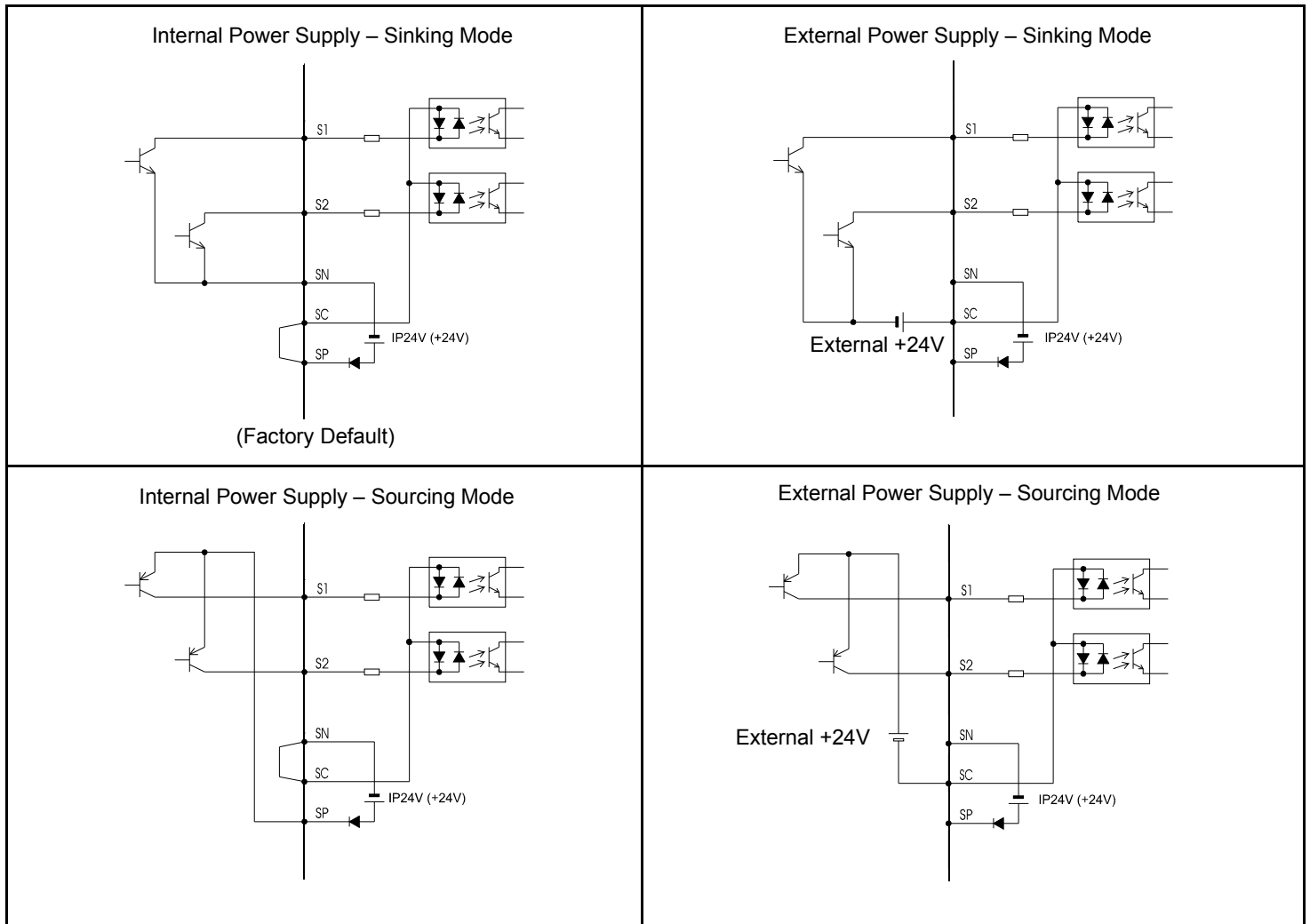

◆ Control Circuit Terminal Connections

■ iQpump Drive Factory Default

Connections to iQpump drive terminals for the default factory settings are shown in *Figure 2.6*.

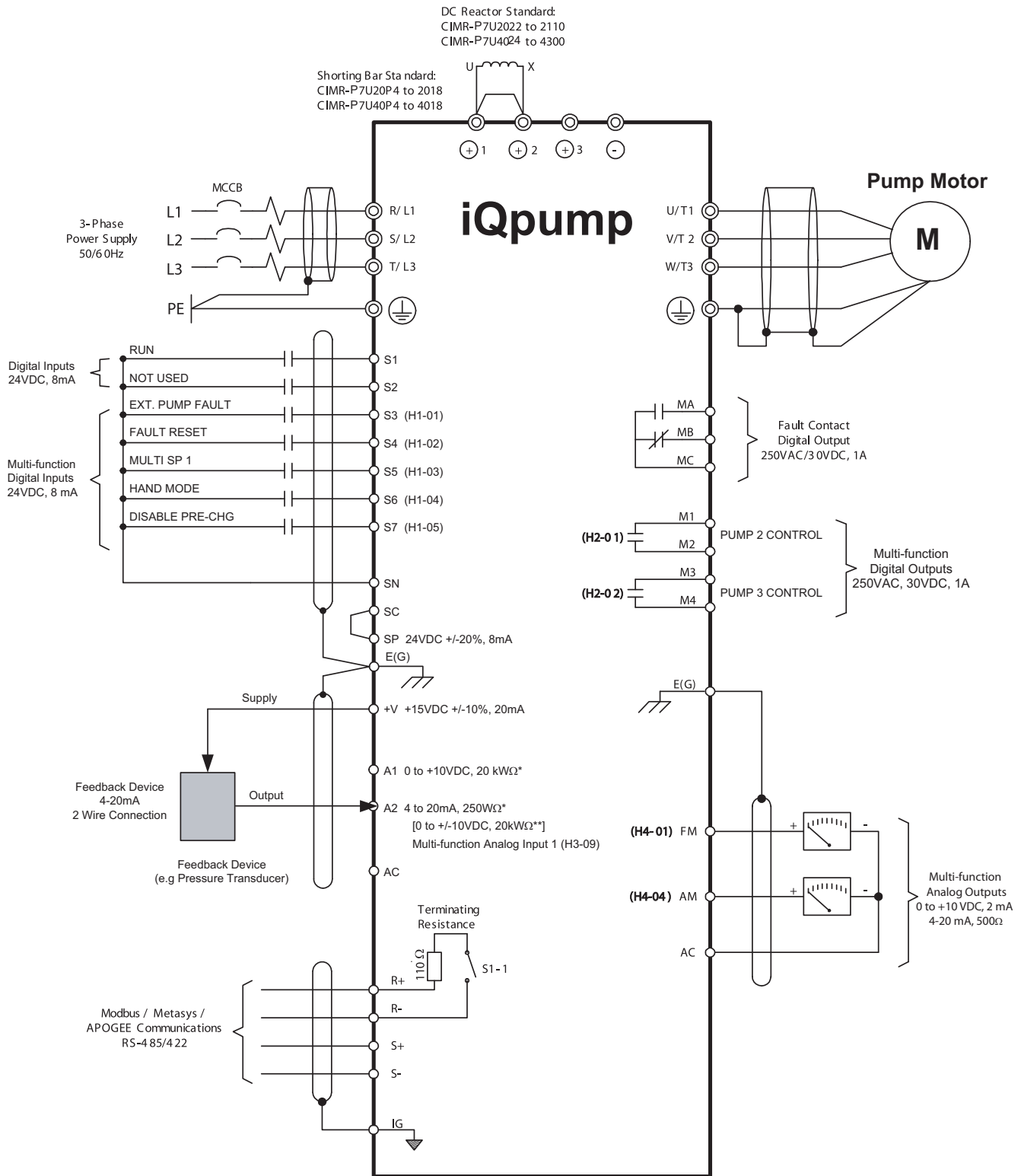

Figure 2.6 Default Terminal Connections

◆ Control Circuit Wiring Precautions

Observe the following precautions when wiring control circuits:

1. Separate control wiring from power/motor wiring (terminals R/L1, S/L2, T/L3, U/T1, V/T2, W/T3, \ominus , $\oplus 1$, $\oplus 2$, and $\oplus 3$) and other high-power lines.
2. Separate wiring for control circuit terminals MA, MB, MC, M1, M2, M3, and M4 (digital outputs) from wiring to other control circuit terminals.
3. If using an optional external power supply, ensure it is a UL Listed Class 2 power supply source.
4. Use twisted-pair or shielded twisted-pair cables for control circuits to prevent operating faults. Prepare cable ends as shown in [Figure 2.7](#).
5. Connect the shield wire to terminal E (G).
6. Insulate the shield with tape to prevent contact with other signal lines and equipment.

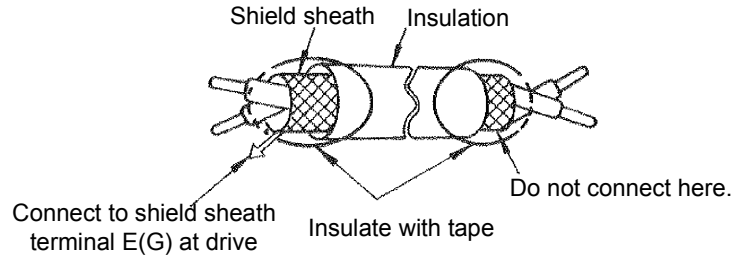

Figure 2.7 Preparing the Termination of Shielded Twisted-pair Cables

■ Duplex Pump System Wiring

Connections to the Multi-function Digital Outputs for a Duplex Pump system.

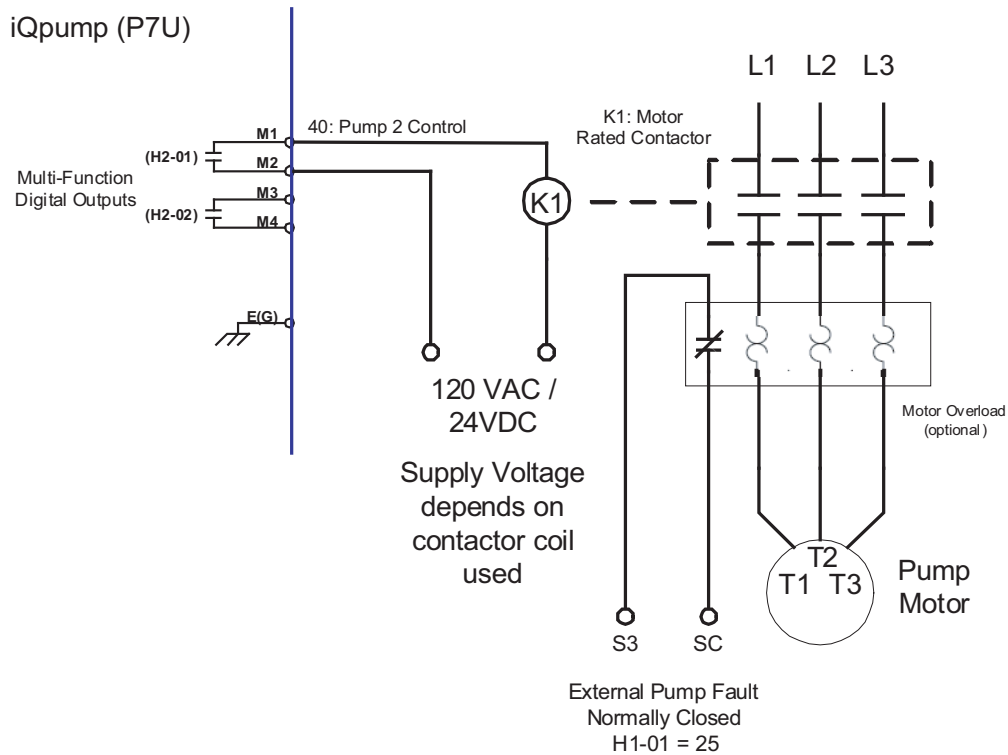

Figure 2.8 Duplex Pump System Wiring

■ Triplex Pump System Wiring

Connections to the Multi-function Digital Outputs for a Triplex Pump system.

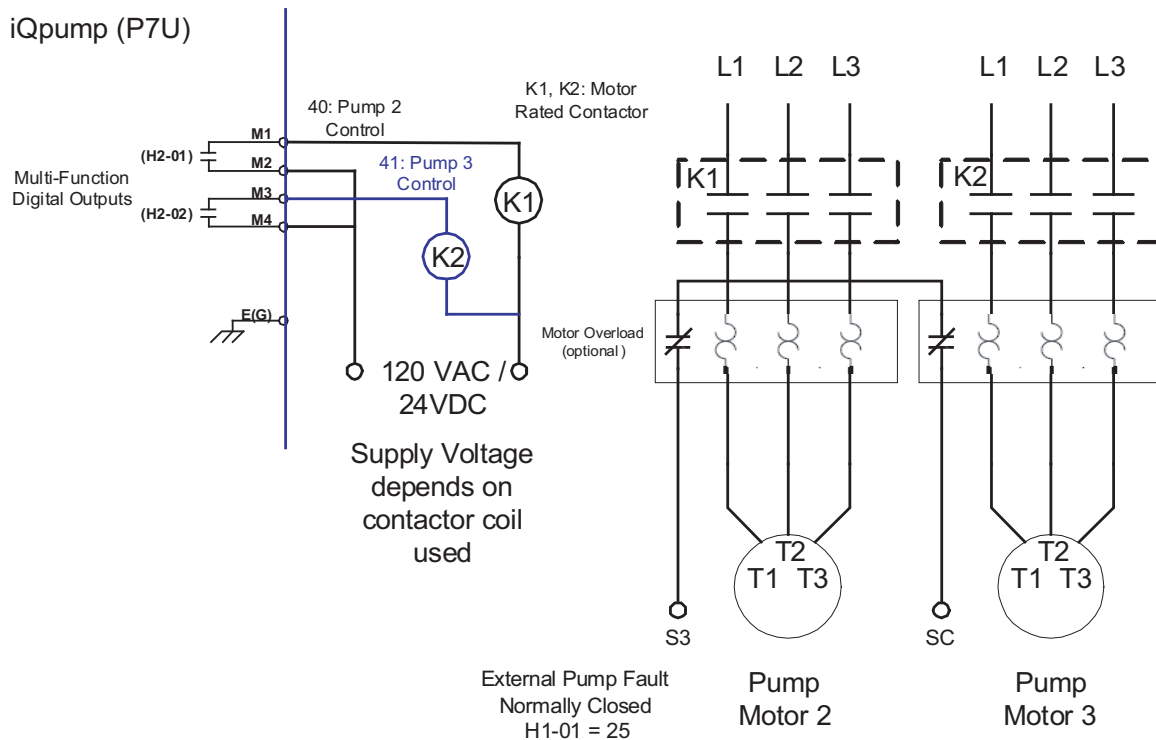

Figure 2.9 Triplex Pump System Wiring

■ Duplex Pump System with Motor Starter Wiring

Connections to the Multi-function Digital Outputs for a Duplex Pump System using Motor Starters.

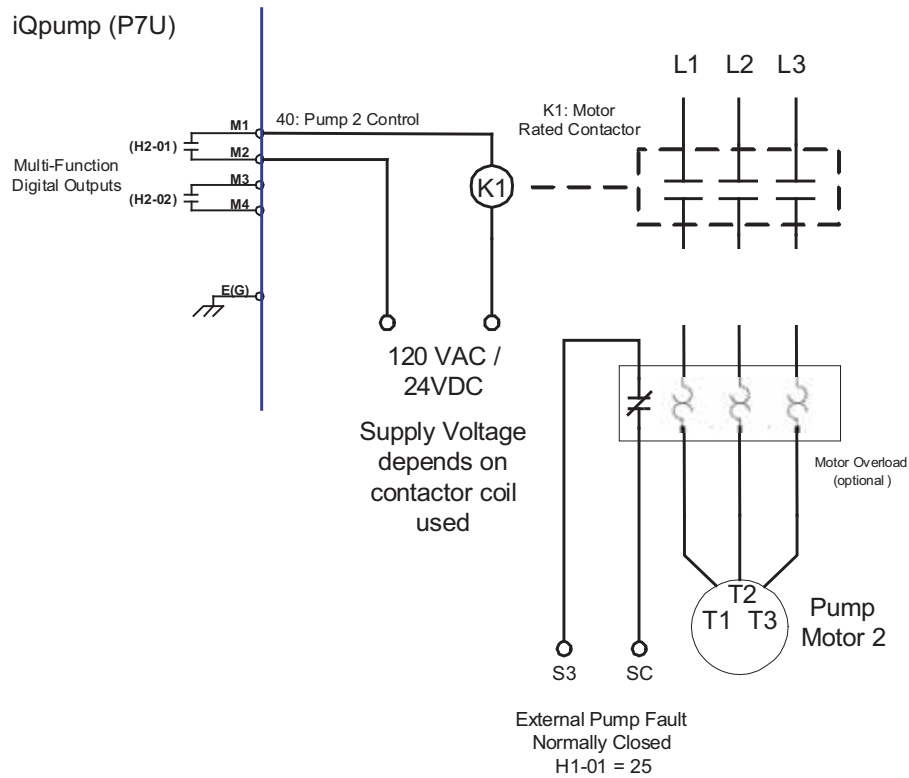

Figure 2.10 Duplex Pump System with Motor Starter Wiring

■ Triplex Pump System with Motor Starters Wiring

Wiring diagram shows connections to the Multi-Function Digital Outputs for a Triplex Pump System using Motor Starters.

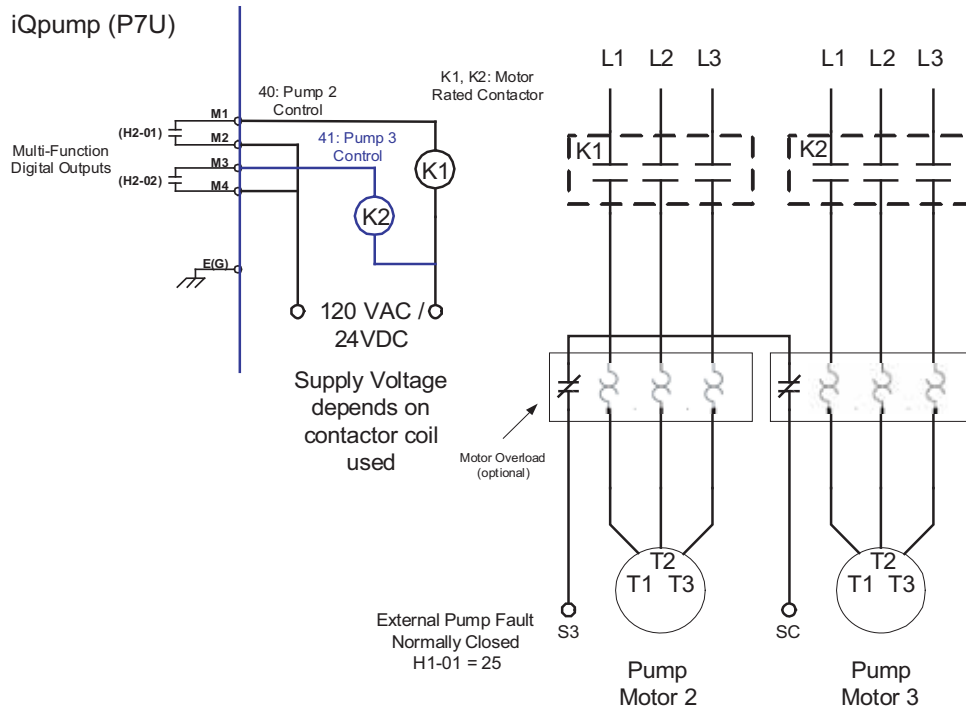

Figure 2.11 Triplex Pump System with Motor Starters

■ Feedback Device (3-Wire)

Connection of a 3-Wire 0 ~ 10 Vdc Feedback Device (H3-08 = 0)

In order to use a 4 ~ 20 mA feedback device, parameter H3-08 Terminal A2 Signal has to be programmed to 2.

Note: In order to use a 0 ~ 10V feedback device parameter for terminal A2, the parameter H3-08 Terminal A2 Signal has to be programmed to 0 and DIP Switch S1-2 has to be set to OFF for the iQpump to accept a 0 ~ 10 Vdc signal.

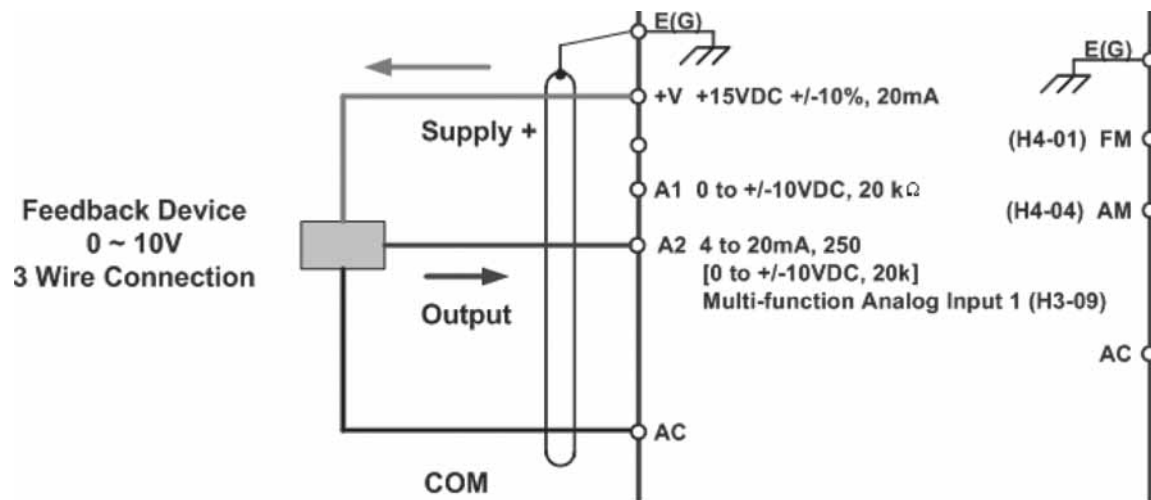
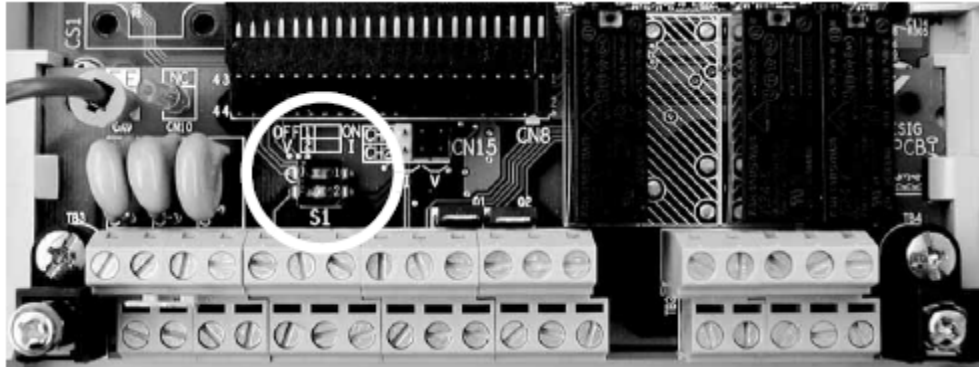

Figure 2.12 Feedback Device (3-Wire) Connection

2.3 Control Wiring

THIS PAGE INTENTIONALLY BLANK.



Digital Operator

This chapter describes the displays and functions of the Digital Operator.

3.1 Digital Operator Display	58
3.2 Digital Operator Keys	59
3.3 Drive Mode Indicators	60
3.4 Drive Main Menu	62
3.5 Pump Quick Setup Menu (-QUICK-)	67
3.6 Programming Menu (-ADV-)	68
3.7 Example of Changing a Parameter	70

3.1 Digital Operator Display

The digital operator is used for programming, operating, and monitoring iQpump drive operation. By default, the iQpump drive will not run unless the digital operator is securely attached to the iQpump drive.

The various items included on the digital operator are described below.

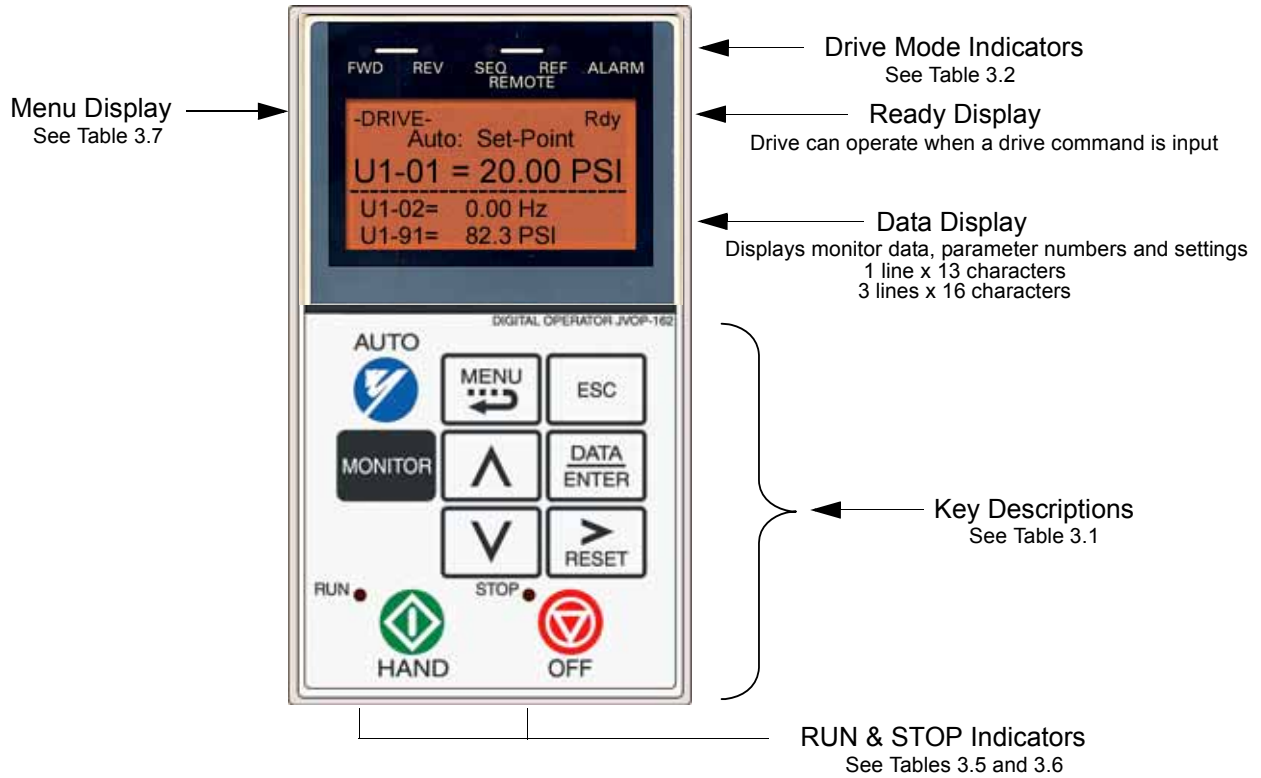

Figure 3.1 Digital Operator Component Names and Functions











⚠ WARNING

The digital operator can be used to operate (start) the iQpump drive. Incorrect programming and / or improper key selection on the digital operator may result in the iQpump drive starting unexpectedly. Prior to making any adjustments with the digital operator, insure that all personnel are clear from the iQpump drive, motor, and machine. Also, insure that all covers, couplings, pulleys, shaft keys, etc. are secure.

3.2 Digital Operator Keys

The names and functions of the digital operator Keys are described in [Table 3.1](#).

Table 3.1 Digital Operator Keys

Key	Name	Function
	AUTO Key	<ul style="list-style-type: none"> Pressing the AUTO key will put the drive in the “Auto” mode. In the “Auto” mode, the drive will be capable of starting / stopping depending on the setting of parameter “b1-02” (Run Command Selection). In the “Auto” mode, the drive setpoint will depend on the setting of parameter “b1-01” (Reference Source). If the OFF key is pressed, the “Auto” mode frequency reference will continue to be displayed on the keypad. Pressing the AUTO key will start the drive if the run command is already closed. If the drive is running in the “Auto” mode and the OFF key is pressed, the drive will stop. If the run command remains closed, pressing the AUTO key will restart the drive. While the drive is running, the run command can be opened to stop and closed to restart without taking the drive out of the “Auto” mode.
	MENU Key	Scrolls through the five main menus.
	ESCAPE Key	Returns to the previous display, before the DATA / ENTER key was pressed.
	MONITOR Key	Selects the monitor mode from the Operation (-DRIVE-), Quick Setting (-QUICK-), Programming (-ADV-) and Modified Constants (-VERIFY-) menus + A.TUNE.
	INCREASE Key	Increases parameter numbers and set values. Used to move to the next item or data value.
	DECREASE Key	Decreases parameter numbers and set values. Used to move to the previous item or data value.
	SHIFT / RESET Key	Selects the digit to be changed. The selected digit will blink. Also resets the drive when a fault has occurred, if the fault condition doesn't exist anymore and there isn't an active RUN command.
	DATA / ENTER Key	Pressed to enter menus and parameters as well as to set values.
	HAND Key	<ul style="list-style-type: none"> Pressing the HAND key will put the drive in the “Hand” mode and start the drive. In the “Hand” mode, the drive speed command will depend on the setting of parameter “P5-01” (Hand Mode Source and P5-02 Hand Reference). If the OFF key is pressed, the “Hand” mode speed command will continue to be displayed on the keypad.
	OFF Key	Stops drive operation, following the stopping method as programmed in parameter b1-03.

3.3 Drive Mode Indicators

The definitions of the iQpump drive mode indicators are shown in [Table 3.2](#).

Table 3.2 iQpump Drive Mode Indicators

Indicator	Definition
FWD	Lit when a forward run command is input and when drive is in “Hand” Mode.
AUTO SEQ	Lit when set up for remote run command. See Table 3.3 .
AUTO REF	Lit when set up for remote speed command. See Table 3.4 .
ALARM	Lit when a fault has occurred. Flashes when an alarm has occurred.

◆ AUTO Sequence (SEQ) Indicator

The status of the AUTO “Sequence” (SEQ) indicator is shown in [Table 3.3](#). This indicator is always “Off” when the iQpump drive is in the “Hand” mode. When the iQpump drive is in the “Auto” mode, the SEQ indicator status is dependent on the setting of parameter “b1-02” (Run Command Selection).

Table 3.3 AUTO Sequence (SEQ) Indicator

Indicator Status	Hand Mode	Auto Mode
On	N/A	Parameter “b1-02” (Run Command Selection) is set to terminal strip, communications, or an option board as indicated below: b1-02= 1 (Terminals) = 2 (Communications) = 3 (Option PCB)
Off		Parameter “b1-02” (Run Command Selection) is set to digital operator as indicated below: b1-02 = 0 (Operator)

The status of the AUTO “Reference” (REF) indicator is shown in [Table 3.4](#). This indicator is always “Off” when the iQpump drive is in the “Hand” mode. When the iQpump drive is in the “Auto” mode, the REF indicator status is dependent on the setting of parameter “b1-01” (Frequency Reference Selection).

Table 3.4 AUTO Reference (REF) Indicator

Indicator Status	Hand Mode	Auto Mode
On	N/A	Parameter “b1-01” (Frequency Reference Selection) is set to terminal strip, communications, or an option board as indicated below: b1-01= 1 (Terminals) = 2 (Communications) = 3 (Option PCB)
Off		Parameter “b1-01” (Frequency Reference Selection) is set to digital operator as indicated below: b1-01= 0 (Operator)

◆ Run Indicator

The status of the “RUN” indicator is shown in [Table 3.5](#) when the iQpump drive is in either the “Hand” or “Auto” mode.

Table 3.5 RUN Indicator

Indicator Status	Condition
On	Drive is running
Blinking	Drive is decelerating to a stop
Off	Drive is stopped

◆ Stop Indicator

The status of the “STOP” indicator is shown in [Table 3.6](#) when the iQpump drive is in either the “Hand” or “Auto” mode.

Table 3.6 STOP Indicator

Indicator Status	Condition
On	Drive is decelerating to a stop or stopped
Blinking	Drive is in a run condition but the frequency reference is zero or drive is running in “Auto” mode and OFF has been pressed
Off	Drive is running

3.4 Drive Main Menu

The iQpump drive's parameters and monitoring functions are organized into menu groups that make it easier to read and set parameters. The iQpump drive is equipped with five menu selections. The five selections and their primary functions are shown in [Table 3.7](#) and are directly available by pressing the MENU key.

Table 3.7 iQpump Drive Menu Selections

Main Menu	Primary Function(s)
Operation - DRIVE -	The drive can be run in this menu. Use this menu for monitoring values such as frequency reference or output current, displaying fault history or displaying the fault traces.
Pump Quick Setup - QUICK -	The drive can be programmed in this menu. Use this menu to set / read the most commonly used parameters.
Programming - ADV -	The drive can be programmed in this menu. Use this menu to set / read every parameter.
Modified Constants - VERIFY -	The drive can be programmed in this menu. Use this menu to set / read the parameters that have been modified from their factory default settings.
Auto-Tuning - A.TUNE -	The drive can be programmed in this menu. Use this menu to auto-tune the drive in order to optimize motor control as well as utilize the bi-directional speed search feature.

◆ Pump Quick Setup Main Menu Structure

The menu selection display will appear when the MENU key is pressed from a monitor or setting display. While viewing the menu selection display, press the MENU key repeatedly to scroll between the menu selections.

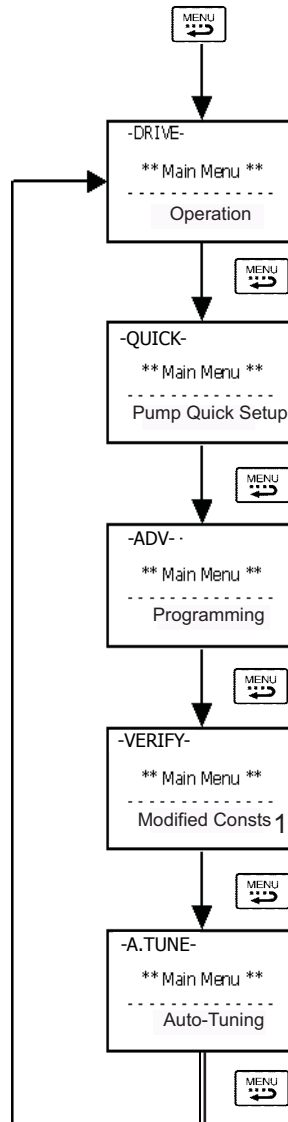

Figure 3.2 Main Menu Structure

Press the DATA / ENTER key to enter the desired menu selection.

¹ Modified Consts = Modified Parameters

◆ Operation Menu (-DRIVE-)

This menu is used for setting a speed command or monitoring values such as output frequency and output current. It is also used for displaying the fault history and the fault traces. The iQpump drive must be in this menu in order to run, see parameter b1-08.

IMPORTANT

- Leaving the iQpump drive in a menu other than the Operation Menu, will prohibit the iQpump drive from running. While running, if the iQpump drive is in a menu other than “Operation” and the run command is removed and re-applied, the iQpump drive will stop and will not start until the Operation Menu is selected unless b1-08 = 1.

■ U1 Monitor List

Follow the key operations below (Figure 3.3) to access the Operation Menu:

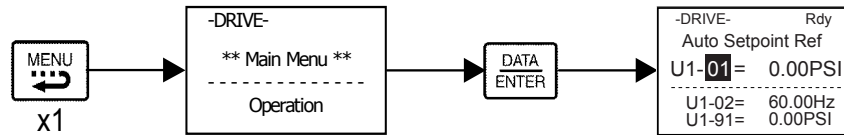

Figure 3.3 U1 Monitor List Access Procedure



Use  and  keys to scroll through the U1 Monitor Parameter List. Refer to Parameters on page 165 for functional description.

Table 3.8 U1 Monitor Parameter List

Monitor	Parameter Name Digital Operator Display	Monitor	Parameter Name Digital Operator Display
U1-01	Auto Setpoint Reference Auto: Setpoint	U1-29	kWh kWh Lo 4 Digits
U1-02	Output Frequency Output Freq	U1-30	MWh kWh Hi 5 Digits
U1-03	Output Current Output Current	U1-34	First Parameter Causing an OPE OPE Detected
U1-06	Output Voltage Output Voltage	U1-36	PI Input PI Input
U1-07	DC Bus Voltage DC Bus Voltage	U1-37	PI Output PI Output
U1-08	Output Power Output kWatts	U1-38	PI Setpoint PI Setpoint
U1-10	Input Terminal Status Input Term Sts	U1-39	Memobus Communication Error Code Transmit Err
U1-11	Output Terminal Status Output Term Sts	U1-40	Heatsink Cooling Fan Operation Time FAN Elapsed Time
U1-12	Drive Operation Status Int Ctl Sts 1	U1-54	Network PI Feedback Net PI Feedback
U1-13	Cumulative Operation Time Elapsed Time	U1-55	Pump Network Status 1 PumpNet Status1
U1-14	Software Number FLASH ID	U1-56	Pump Network Status 2 PumpNet Status2
U1-15	Terminal A1 Input Voltage Term A1 Level	U1-57	Pump Network Status 3 PumpNet Status3
U1-16	Terminal A2 Input Voltage Term A2 level	U1-58	Pump Network Status 4 PumpNet Status4
U1-18	Motor Secondary Current (Iq) Mot SEC Current	U1-59	Pump Network Control 1 PumpNet Control1
U1-20	Output Frequency After Soft Start SFS Output	U1-60	Pump Network Control 2 PumpNet Control2
U1-24	PI Feedback Value PI Feedback	U1-62	Running Queue No Running Queue No
U1-28	CPU Number CPU ID	U1-63	Pump Running 1 Pump Running1

Monitor	Parameter Name Digital Operator Display	Monitor	Parameter Name Digital Operator Display
U1-64	Pump Running 2 Pump Running2	U1-92	Pump Status Pump Status
U1-65	Pump Available 1 Pump Available1	U1-93	Total Setpoint Compensation Total SP Comp.
U1-66	Pump Available 2 Pump Available2	U1-94	Motor Speed Motor Speed
U1-67	Network Activity Network Activity	U1-95	Flow Rate Flow Rate
U1-68	Time to Alternate Time to Alternate	U1-96	Volume Accumulated (fine) Volume (fine)
U1-90	Pump Setpoint Reference Pump Setpoint	U1-97	Volume Accumulated (course) Volume (course)
U1-91	Pump Feedback Pump Feedback	U1-98	Water Level Water Level
U1-92	Pump Status Pump Status	U1-99	Anti-No-Flow Timer ANF Timer

■ U2 Fault Trace List

After viewing the “Monitor” parameter list, in order to view the “Fault Trace” parameter list, follow the key operations below *Figure 3.4*.

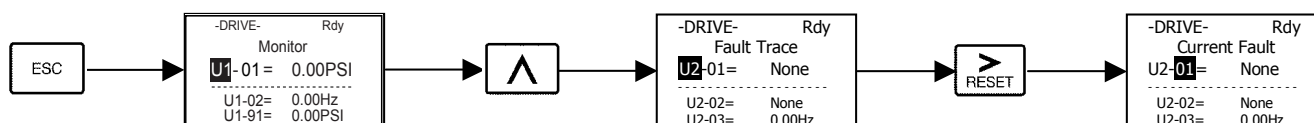

Figure 3.4 U2 Fault Trace List Access Procedure

Use and keys to scroll through the U2 Fault Trace Parameter List.

Table 3.9 U2 Fault Trace Parameter List

Fault Trace Parameters	
U2-01	Current Fault
U2-02	Last Fault
U2-03	Frequency Ref
U2-04	Output Freq
U2-05	Output Current
U2-07	Output Voltage
U2-08	DC Bus Voltage
U2-09	Output kWatts
U2-11	Input Term Sts
U2-12	Output Term Sts
U2-13	AC Drive Status
U2-14	Elapsed Time

■ U3 Fault History List

After viewing the “Fault Trace” parameter list, in order to view the “Fault History” parameter list, follow the key operations below (Figure 3.5.)

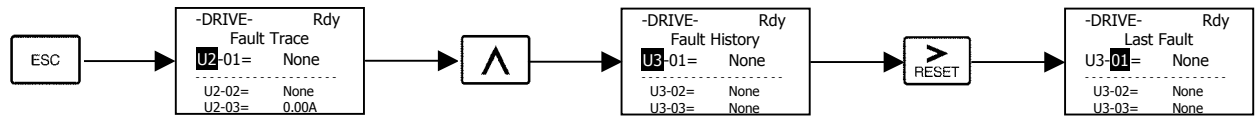

Figure 3.5 U3 Fault History Access Procedure

Use and keys to scroll through the U3 Fault History Parameter List.

Table 3.10 U3 Fault History Parameter List

Fault History Parameters	
U3-01	Last Fault
U3-02	Fault Message 2
U3-03	Fault Message 3
U3-04	Fault Message 4
U3-05	Elapsed Time 1
U3-06	Elapsed Time 2
U3-07	Elapsed Time 3
U3-08	Elapsed Time 4
U3-09	Fault Message 5
U3-10	Fault Message 6
U3-11	Fault Message 7
U3-12	Fault Message 8
U3-13	Fault Message 9
U3-14	Fault Message 10
U3-15	Elapsed Time 5
U3-16	Elapsed Time 6
U3-17	Elapsed Time 7
U3-18	Elapsed Time 8
U3-19	Elapsed Time 9
U3-20	Elapsed Time 10

3.5 Pump Quick Setup Menu (-QUICK-) H

This menu is used to set / read the most commonly used parameters in the iQpump drive. Follow the key operations below (*Figure 3.6*) to access the Pump Quick Setup Menu

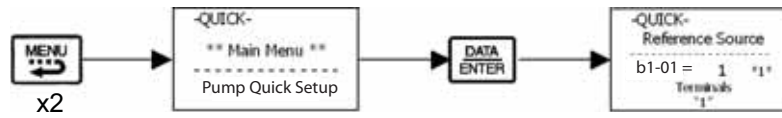

Figure 3.6 Pump Quick Setup Parameter Access Procedure



Use  and  keys to scroll through the Quick Setting Parameter List.

Table 3.11 Pump Quick Setup Parameter List

Parameter Number	Parameter Name
E2-01	Motor Rated Current
E2-04	Number of Motor Poles
P1-03	Feedback Device Scaling
d1-01	Setpoint Reference 1
P1-04	Start Level
P1-06	Minimum Pump Frequency
P4-10	Auto Mode Operator Run Power Down Storage
P5-04	Hand Key Function Selection

3.6 Programming Menu (-ADV-)

This menu is used to set / read every parameter in the iQpump drive. Follow the key operations below (Figure 3.7) to access the Programming Menu.

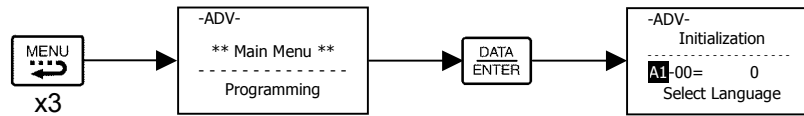

Figure 3.7 Programming Menu Access Procedure

Use \uparrow , \downarrow , and RESET keys to scroll through the Programming Parameter Group List. For complete parameter listing Refer to Parameters on page 165.

Table 3.12 Programming Parameter Group List

Parameter Group Functions		Parameter Group Functions	
A1	Initialization	L1	Motor Overload
b1	Sequence	L2	PwrLoss Ridethru
b2	DC Braking	L3	Stall Prevention
b3	Speed Search	L4	Ref Detection
b4	Delay Timers	L5	Fault Restart
b5	PI Control	L6	Torque Detection
b8	Energy Saving	L8	Hdwe Protection
C1	Accel /Decel	n1	Hunting Prev
C2	S-Curve Acc / Dec	n3	High Slip
C4	Torque Comp	o1	Monitor Select
C6	Carrier Freq	o2	Key Selections
d1	Preset Reference	o3	COPY Function
d2	Reference Limits	P1	Pump Basic
d3	Jump Frequencies	P2	Pump Protection
E1	V/F Pattern	P3	Pump Multiplex
E2	Motor Setup	P4	Pump Advanced
F6	Com OPT Setup	P5	Hand Mode
H1	Digital Inputs	P6	Flow Meter Setup
H2	Digital Outputs	P7	Anti-Jam / De-Scale
H3	Analog Inputs	P8	Pressure and Level Control
H4	Analog Outputs	P9	Network Options
H5	Serial Com Setup		

◆ Modified Constants Menu (-VERIFY-)

This menu is used to set / read the parameters that have been modified from their original factory default settings. Follow the key operations below (Figure 3.8) to access the Modified Constants Parameter Menu.

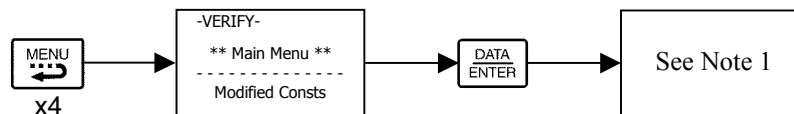

Figure 3.8 Modified Constants Menu Access Procedure

Note: If there are not any parameters that have been modified from their original factory default settings, then the display will state “None Modified.” Otherwise, use the “increase” and “decrease” keys to scroll through the “Modified Constants” list.

◆ Auto-Tuning Menu (-A.TUNE-)

This menu is used to auto-tune the iQpump drive in order to optimize motor control as well as utilize the bi-directional speed search feature. Follow the key operations below (Figure 3.9) to access the Auto-Tuning Menu.

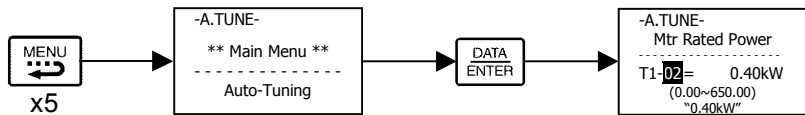

Figure 3.9 Auto-Tuning Menu Access Procedure

Use and keys to scroll through the Auto-Tuning Parameter List.

Table 3.13 Auto-Tuning Parameter List

Auto-Tuning Parameters	
T1-02	Mtr Rated Power
T1-04	Rated Current

3.7 Parameter Editing Example

Table 3.14 provides an example of how to change parameter C1-02 (Deceleration Time 1) from 30 seconds to 40 seconds.

Table 3.14 Changing a Parameter in the Programming Menu

Step Number	Digital Operator Display	Description
1	<pre> -DRIVE- Rdy Auto: Setpoint Ref U1-01 = 0.0PSI ----- U1-02 = 0.00Hz U1-91 = 0.00PSI </pre>	The drive is first powered up.
2	<pre> -DRIVE- ** Main Menu ** ----- Operation </pre>	Press the MENU key to scroll to “Operation” menu.
3	<pre> -QUICK- ** Main Menu ** ----- Pump Quick Setup </pre>	Press the MENU key to scroll to “Pump Quick Setup” menu.
4	<pre> -ADV- ** Main Menu ** ----- Programming </pre>	Press the MENU key to scroll to “Programming” menu.
5	<pre> -ADV- Initialization ----- A1-01= 0 Select Language </pre>	Press the DATA / ENTER key to enter “Programming” menu.
6	<pre> -ADV- Accel/Decel ----- C1-01= 1.0sec Accel Time 1 </pre>	Press the INCREASE key until C1-01 (Accel / Decel) is displayed.
7	<pre> -ADV- Accel Time 1 ----- C1-01= 30.0sec (0.0~6000.0) "30.0sec" </pre>	Press the SHIFT / RESET key to move flashing digit to the right.
8	<pre> -ADV- Decel Time 1 ----- C1-02= 30.0sec (0.0~6000.0) "30.0sec" </pre>	Press the INCREASE key to display C1-02 (Decel Time 1).
9	<pre> -ADV- Decel Time 1 ----- C1-02= 030.0sec (0.0~6000.0) "30.0sec" </pre>	Press the DATA / ENTER key to access setting display.
10	<pre> -ADV- Decel Time 1 ----- C1-02= 0030.0sec (0.0~6000.0) "30.0sec" </pre>	Press the SHIFT/RESET key to move the flashing digit to the right.

Step Number	Digital Operator Display	Description
11	<div style="border: 1px solid black; padding: 5px; width: fit-content; margin: auto;"> -ADV- Decel Time 1 ----- C1-02= 000.0sec (0.0~6000.0) "30.0sec" </div>	Press the SHIFT/RESET key to move the flashing digit to the right.
12	<div style="border: 1px solid black; padding: 5px; width: fit-content; margin: auto;"> -ADV- Decel Time 1 ----- C1-02= 004.0sec (0.0~6000.0) "30.0sec" </div>	Press the INCREASE key to increase the set data.
13	<div style="border: 1px solid black; padding: 5px; width: fit-content; margin: auto;"> -ADV- Entry Accepted </div>	Press the DATA / ENTER key to enter the set data. "Entry Accepted" is displayed for 1.0 sec after the data setting has been confirmed.
14	<div style="border: 1px solid black; padding: 5px; width: fit-content; margin: auto;"> -ADV- Decel Time 1 ----- C1-02= 40.0 sec (0.0~6000.0) "30.0sec" </div>	The monitor display for C1-02 returns.
16	<div style="border: 1px solid black; padding: 5px; width: fit-content; margin: auto;"> -DRIVE- Rdy Auto: Setpoint Ref U1-01 = 0.0PSI ----- U1-02 = 0.00Hz U1-01 = 0.00PSI </div>	Press the MONITOR key on the HOA keypad to enter "Operation" menu.

3.7 Parameter Editing Example

THIS PAGE INTENTIONALLY BLANK.



Start-Up

This chapter describes the procedures to prepare the iQpump drive for start up and the procedures to conduct an iQpump drive start up.

4.1 Start Up	74
4.2 iQpump Drive Start Up Procedures	77

4.1 Start-Up

In order to provide the most reliable iQpump drive available and to avoid any extra costs related to loss or reduction of warranty coverage, an authorized Yaskawa service representative should complete this start-up procedure. Please complete the following checklist and maintain it in a secure location as technical service personnel may request information from this checklist.

◆ Drive Start Up Preparation

Date: _____

Start-Up Person:

Company Name: _____

Start-Up Location: _____

Sales Order #: _____

Serial #: _____

Printed Name: _____

Drive Location: _____

Phone #: _____

Signature: _____

Owner's Representative:

Printed Name: _____

Phone #: _____

Company: _____

Signature: _____

Step

- 1. The iQpump drive is thoroughly tested at the factory. The start up person should verify that the iQpump drive is free of shipping and installation damage. Shipping damage is not covered by the Yaskawa warranty. Claims must be filed with the shipping company as soon as possible for any potential recovery via insurance.
- 2. Review the iQpump Drive User Manual (TM.iQp.06) shipped with the iQpump drive.
- 3. Verify that the model number and voltage ratings in the purchase order match the nameplate data for each unit.
- 4. Location of the iQpump drive is important to achieve proper performance and normal operating life. The unit should be installed in an area where it is protected from:
 - Direct sunlight, rain or moisture
 - Corrosive gases or liquids
 - Vibration, airborne dust or metallic particles
- 5. Ensure the iQpump drive is on a vertical surface with adequate space for air circulation (4.75" above and below, 1.2" on each side). Refer to [Figure 1.5](#).
- 6. Verify that the proper branch circuit protection is installed in front of the iQpump drive. Refer to [Appendix E Peripheral Devices](#) for proper input fuse or circuit breaker sizing.
- 7. Avoid running input and output wiring in the same conduit.
- 8. Avoid routing power wiring near equipment sensitive to electrical noise.

- 9. Never allow wire leads to touch metal surfaces. Short-circuit may result.
- 10. Never connect AC main power output terminals U/T1, U/T2 and W/T3.
- 11. Never connect power factor correction capacitors or noise filters to the iQpump drive output.
- 12. Use 600 Vac vinyl-sheathed wire or equivalent. Wire size should be determined considering voltage drop of leads.
Line voltage drop (V) = $\sqrt{3}$ x wire resistance (Ω /km) x wire length (m) x current (A) x 10^{-3}
- 13. It is recommended that the motor lead length not exceed 164 feet (50 meters) and motor wiring be run in a separate conduit from the power wiring. If lead length must exceed this distance, reduce the carrier frequency (see [Figure 2.6](#)) and consult Yaskawa toll free at 1-800-YASKAWA (927-5292) for other motor protection measures.
- 14. Signal and control leads must be separated from main circuit leads (R/L1, S/L2, T/L3, U/T1, V/T2, W/T3).
- 15. Determine proper wire size for power and motor leads. Refer to [Table 2.1](#) and [Table 2.2](#) for details.
- 16. Review proper ground connections for the iQpump drive. Refer to [Chapter 2](#) for details. The iQpump drive must be solidly grounded using the main circuit ground terminal. Ground resistance should be less than 100Ω for a 208-240 Vac iQpump drive. Ground resistance should be less than 10Ω for a 480 Vac iQpump drive. Select wire size suitable for the size of terminal screw. Make the length as short as possible.

Never ground the iQpump drive in common with welding machines, motors or other large-current electrical equipment.

Where several iQpump drives are used, ground each iQpump drive directly or daisy-chain to the ground pole(s).
DO NOT FORM A LOOP WITH THE GROUND LEADS. See [Table 2.4](#).
- 17. Review terminal functions of signal and control circuits. Refer to [Table 2.8](#).
- 18. Verify if any customer safety devices are required (e.g. External Pump Fault).
- 19. Record the following motor nameplate information:

Voltage: _____ Motor Rated Amps: _____
- 20. Verify that the commercial power supply is within the rated iQpump drive input voltage:

Power Supply: _____ Vac Drive Input Voltage: _____ Vac
- 21. Verify that the leads in the 3-Phase electric motor conduit box are configured for the proper voltage.
- 22. Ensure Motor Rated Current is less than or equal to iQpump drive Output Amps. If multiple motors are being used, make sure that the Motor Rated Current sum is less than or equal to iQpump drive Output Amp rating. Please note that if multiple motors are being operated from one iQpump drive, each motor must have its own overload and short circuit protection.
- 23. Wire all necessary power leads to the iQpump drive. **DO NOT CONNECT MOTOR TO iQpump DRIVE YET.**
- 24. Wire all necessary ground wires to the iQpump drive.

4.1 Start-Up

- 25. Wire all necessary control wires to the iQpump drive.
- 26. Ensure that the power leads are connected to the R/L1, S/L2 and T/L3 terminals in the iQpump drive.
- 27. Tighten all of the three-phase power and ground connections. Please check that all control and signal terminations are tight.
- 28. Inspect the control circuit connections (including the shield) and determine if a motor “safety circuit” is connected.

If normally closed, these contacts may be wired in series with the **RUN** command contacts, which are between terminals **S1** and **SN** of the iQpump drive. No special programming is required. Refer to *Chapter 2*.

Alternately, these contacts could be wired between terminals **S3** and **SN** as **External Fault Inputs**, and may be either normally closed or normally open contacts.
- 29. Record any other connections to the iQpump drive using the blank terminal connection drawing in Chapter 2 – Electrical Installation (Fig. 2.9) to determine if special programming is required for the following:
 - Multi-function Inputs – *See “Parameters” on page 165.*
 - Multi-function Outputs – *See “Parameters” on page 165.*
 - Multi-function Digital Inputs – *See “Parameters” on page 165.*
 - Multi-function Analog Outputs – refer to *See “Parameters” on page 165.*
 - Serial Communications – refer to *See “Parameters” on page 165.*

THIS COMPLETES THE iQpump DRIVE START UP PREPARATION.

4.2 iQpump Drive Quick Start-Up Procedures

The following procedure will guide the user in properly wiring the iQpump drive and motor. It will also explain iQpump drive configuration for a simplex pump application.

⚠ WARNING

Electrical Shock Hazard. Do not operate equipment with covers removed. Failure to comply could result in death or serious injury.

NOTICE

Check all the wiring to ensure that all connections are correct after installing the iQpump drive and connecting any other devices. Failure to comply could result in damage to the drive.

When installing the system, be sure to follow good wiring practices and all applicable codes. Ensure that the mounting of the various components are secure and that the environment, such as extreme dampness or poor ventilation will not cause system degradation.

◆ Step # 1 - iQpump Drive Model Identification and Mounting

To make sure you received the correct model, verify the iQpump drive nameplate with your order and make sure the iQpump drive has the correct rating for the motor. Please check the nameplate information as shown in the example below.

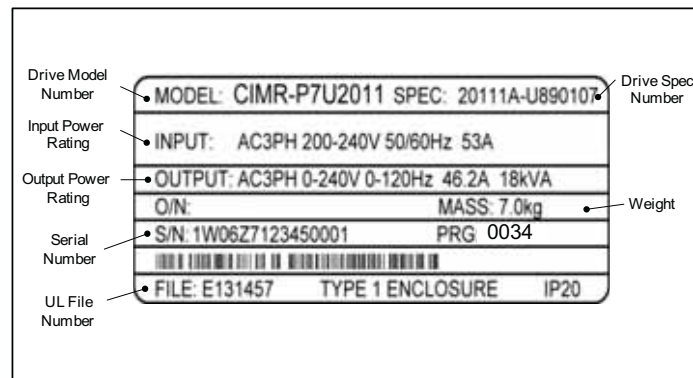

- Check that the available power will meet the input power requirements.
- Ensure that the output power from the iQpump drive is compatible with the pump motor requirements.
- In the case of systems with more than one iQpump drive, follow the above procedure for each iQpump drive and pump motor.

■ Mounting the iQpump Drive

The mounting of the iQpump drive is extremely important regarding environment and accessibility. Depending on your system, there are various models available and the mounting dimensions (footprint) may be different. For more details on mounting the drive, See “Physical Installation” on page 17.

■ Removing the Terminal Cover

Improper removal of the iQpump drive terminal cover as well as front cover can cause extensive damage to the iQpump drive. To avoid damage to these items, See “Removing and Attaching the Terminal Cover” on page 30.

Cover Removal for Models CIMR-P7U20P4 through 2018 (0.5 HP to 25 HP @ 208 V / 240 V) and 40P4 through 4018 (0.5 HP to 30 HP @ 480 V)

Loosen the screw at the bottom of the terminal cover, press in on the sides of the terminal cover in the directions of arrows 1, and then lift up on the terminal in the direction of arrow 2. Refer to [Figure 4.1](#).

4.2 iQpump Drive Quick Start-Up Procedures

Cover Removal for Models CIMR-P7U2022 through 2110 (30 HP to 150 HP @ 208 V / 240V) and 4030 through 4300 (40 HP to 500 HP @ 480 V)

Loosen the screws on the left and right at the top of the terminal cover, pull down the terminal cover in the direction of arrow 1 and then lift up on the terminal cover in the direction of arrow 2. Refer to [Figure 4.2](#).

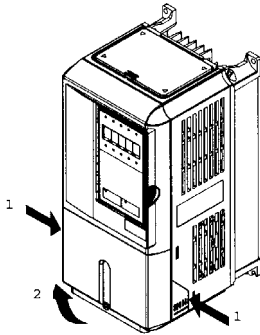

Figure 4.1 Removing the Terminal Cover

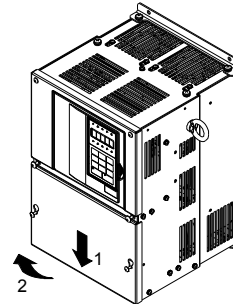

Figure 4.2 Removing the Terminal Cover

■ Attaching the Terminal Cover

After wiring the terminal block, attach the terminal cover by reversing the removal procedure.

Attaching the Terminal Cover for Models CIMR-P7U2018 / 4018-107 and Smaller

insert the tab on the top of the terminal cover into the groove on the iQpump drive and press in on the bottom of the terminal cover until it snaps into place.

Attaching the Terminal Cover for iQpump drives CIMR-P7U2022 / 4030-107 and Larger

Insert the tab on the top of the terminal cover into the groove on the iQpump drive, and secure the terminal cover by lifting it up toward the top of the iQpump drive.

◆ Step # 2 - Connect Pump Motor and Line Power

[Figure 4.3](#) and [Figure 4.4](#) illustrate the electrical connections for the input power and motor terminals for various iQpump models. Select the proper diagram for the model you are installing (see Step 1). WITH POWER OFF make the appropriate connections.

Make sure to follow good wiring practices and all applicable codes. Ensure that the equipment is grounded properly as shown.

⚠ DANGER

LETHAL VOLTAGES ARE PRESENT - Before applying power to the iQpump, ensure that the terminal cover is fastened and all wiring connections are secure. After the power has been turned OFF, wait at least five minutes until the charge indicator extinguishes completely before touching any wiring, circuit boards or components. Failure to comply will result in death or serious injury by electrocution.

NOTICE

DO NOT CONNECT ANY OF THE FOLLOWING TERMINALS TO EARTH GROUND. Damage to the drive will occur.

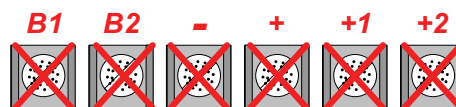

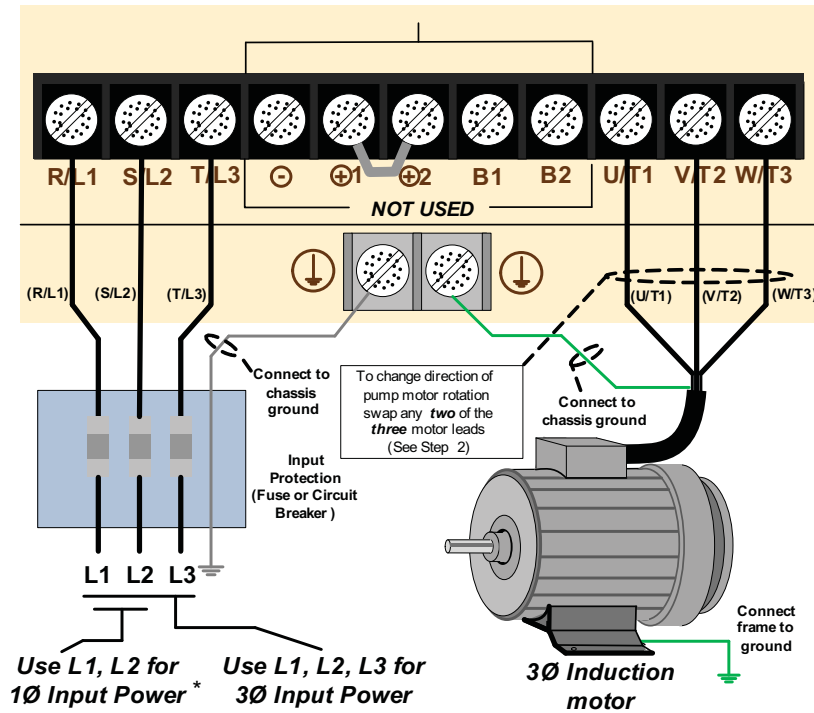

Figure 4.3 Input Power and Output Motor Electrical Connections for Models: 20P4 to 2018 and 40P4 to 4018

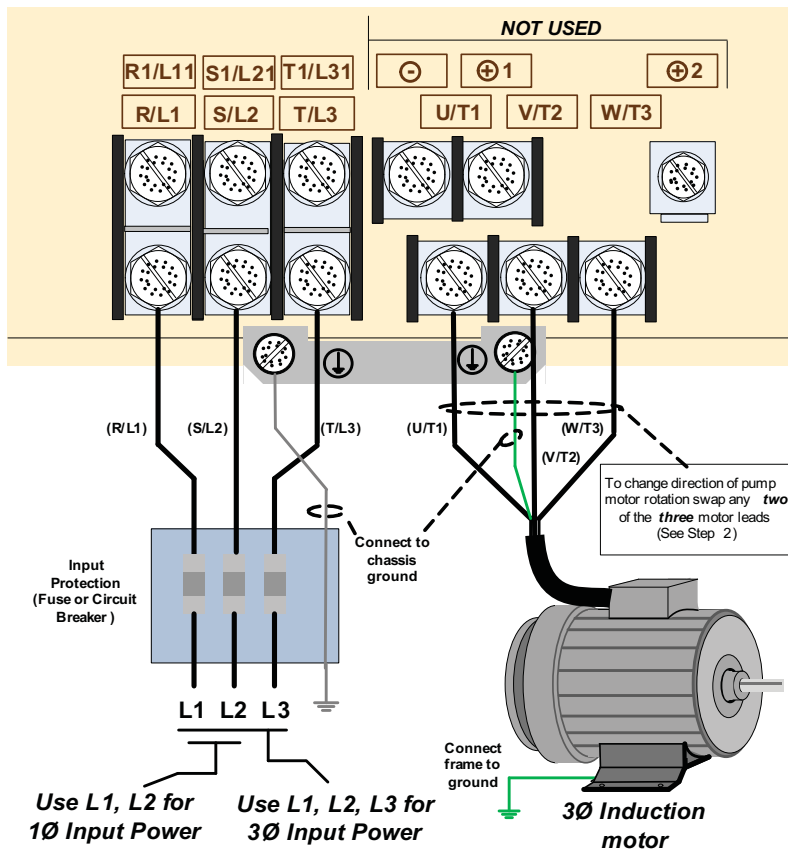

Figure 4.4 Input Power and Output Motor Electrical Connections for Models: 2022 & Larger and 4030 & Larger

Note: *Make sure the iQpump drive has been properly sized for single phase input power.

◆ Step # 3 - Control Wiring

This step shows how to connect control wiring and feedback signal to the iQpump

WARNING! Before making any control connections, turn off power to the iQpump drive! Serious injury or death may occur by electrocution.

Next remove the terminal cover to gain access to the control terminals (Step 1).

■ Select Start / Stop Control Method

The iQpump drive is set to START/STOP FROM THE KEYPAD (digital operator) as the factory default. If this is the preferred start/stop method, then continue to the feedback signal connection section. Please refer to [Figure 4.5](#) to start/stop the iQpump using an external switch or contact.

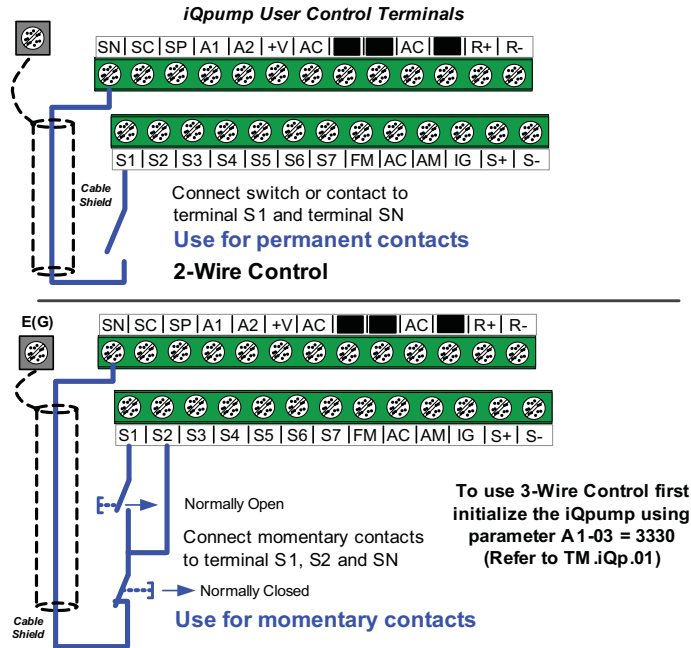

Figure 4.5 Select Start / Stop Control Method

■ Feedback Signal Wiring (Transducer)

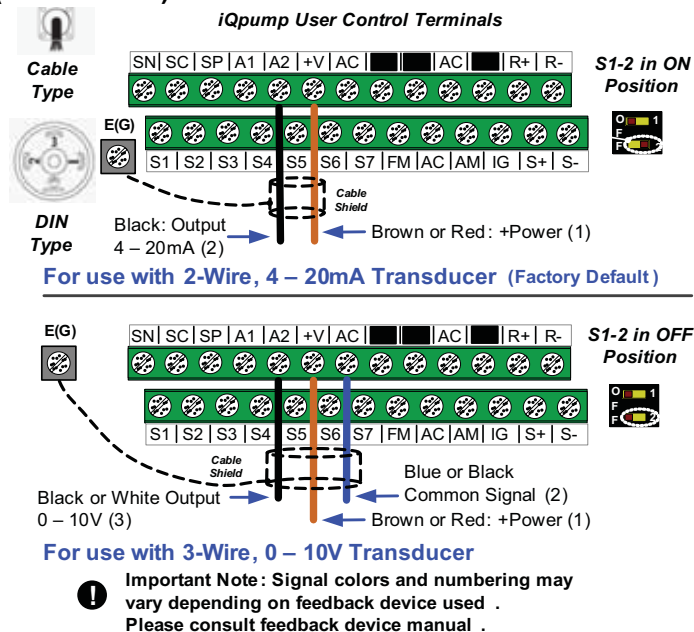

Figure 4.6 Feedback Signal Wiring (Transducer)

◆ Step # 4 - Pump Quick Set-up

In this step, the iQpump drive is set-up for a simplex pump application using the Pump Quick Set-up menu. Apply power to the iQpump drive after all the electrical connections are made and the terminal cover is re-attached. At this point the digital operator should be reading as shown in *Figure 4.7*.

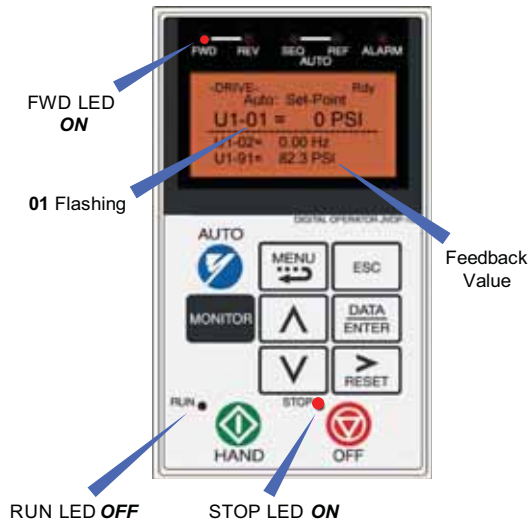

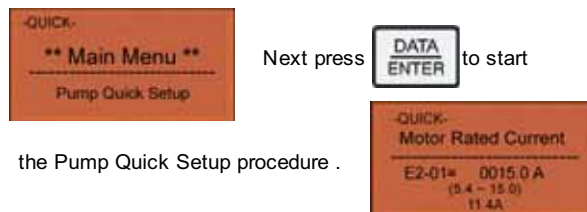





Figure 4.7 Digital Operator

Next, push  2 times on the digital operator until the digital operator shows the **Pump Quick Setup Main Menu**.





The Pump Quick Start Menu consists of the most important parameters to setup your iQpump for use with your pump system.

Press  to access a parameter, and use  to select the digit and use   to change the parameter value.



Press  to save the value

IMPORTANT: Enter service factor amps (SFA) when using an iQpump with a submersible pump motor.

Press  to go to the next parameter to continue the Pump Quick Setup programming. When Quick Setup is completed, press  to exit the Pump Quick Setup menu and go to operation.

Note: Refer to Step 5 for a Pump Quick Setup Parameter Overview.

◆ Step # 5 - iQpump Drive Quick Setup Parameter Overview (Simplex)

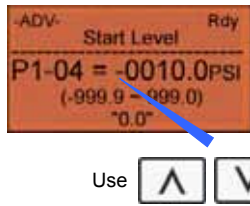
Parameter	Value	Description	Reference	Comments
E2-01	Drive Size Dependent	Motor Rated Current	Set to the motor nameplate full load amps.	For submersible motors use service factor amps (SFA).
E2-04	2	Number of Motor Poles	Number of motor poles is used to show the correct motor RPM on the display. Enter “4” for an 1800 RPM motor and “2” for a 3600 RPM motor.	Confirm number of poles: 2 pole motor - 3600 RPM 4 pole motor - 1800 RPM 6 pole motor - 1200 RPM 8 pole motor - 900 RPM
P1-03	145	Feedback Device Scaling	System Scaling: Enter feedback device maximum. Example: Enter 200 for pressure transducer with a maximum of 200 psi at 20 mA.	Confirm feedback device scaling. (See Figure 4.8)
d1-01	0	Setpoint 1	Set System Setpoint	Set to system pressure.
P1-04	0.0 psi	Start Level	<p>When the iQpump is turned On and the feedback signal level (transducer) falls below this level, the pump system will start after the time specified in P1-05 (default 1 sec).</p> <p>Programming the Start Level as an Absolute Value</p> <p>Start Level has to be programmed to a positive value in order for the Start Level to be an absolute value. Example: Start Level P1-04 set to 50 PSI and delay time P1-05 set to 5 sec. Pump system will start when the pressure drops below 50 PSI for 5 sec.</p> <p>Programming the Start Level as a Delta Level from the System Setpoint</p> <p>Start Level has to be programmed to a negative value in order for the Start Level to be a delta value from the setpoint.</p> <p>Example: Start Level P1-04 set to -10 PSI with a system setpoint of 50 PSI and a delay time P1-05 set to 5 sec. Pump system will start when the pressure drops below 40 PSI (50 - 10) for 5 sec.</p> 	<p>It is mandatory to program the Start Level in order to use the sleep function.</p> <p>(See Figure 4.9)</p>
P1-06	40.0 Hz	Minimum Pump Frequency	Minimum speed (Hz) the pump motor has to operate at. Example: Base pump motor speed is 3600 RPM, minimum speed is 2400 RPM. Set the minimum pump frequency to 40.0 Hz (2400 ÷ 3600 x 60 Hz = 40 Hz)	Minimum pump frequency should be set to a value where the pump enters the no-flow condition.
P4-10	0 Disabled	Auto Mode Operator Run Power Down Storage	Stores the run status in the Auto Mode when operating from digital operator (b1-02 = 0) 0: Disabled 1: Enabled	Recommended for use when Start / Stop command is from keypad. (Refer to Auto Operation - Power Down Storage on page 86)
P5-04	1 Enabled	Hand Key Enable / Disable	Enables or disables the Hand Key on the digital operator. 0: Disabled 1: Enabled	Hand Key on keypad. (See Figure 4.10)
b5-03	3.0 s	PI Integral Time	Decrease integral time to make iQpump more responsive.	NOTICE: May cause system instability if this value is too low.
b5-12	2 (Fault)	PI Feedback Reference Missing Detection Selection	Select what to do when the feedback device (transducer) fails or gets disconnected. 0: Disabled, continue running no message is displayed. 1: Alarm, show warning on the keypad when the feedback device fails or is disconnected. 2: Fault, stop pump system when the feedback fails or is disconnected.	Note: Disable parameter b5-12 if no transducer is installed.

Parameter	Value	Description	Reference	Comments
b5-14	2.0 s	PI Feedback Loss Detection Time	Delay time before iQpump shows alarm or fault when feedback device has failed or is disconnected. Example: 2.0 s, iQpump displays alarm or fault 2 s after the device has failed or is disconnected.	
C1-01	20.0 s	Acceleration Time 1	Time it takes to accelerate the pump motor from zero to maximum speed.	Adjusted depending on system performance.
C1-02	10.0 s	Deceleration Time 1	Time it takes to decelerate the plump motor from maximum speed to zero.	
L5-01	5	Number of Restart Attempts	Determines the number of times iQpump will perform an automatic restart on the faults listed in the comments column. iQpump System Protection Faults that can be setup to restart are Low Level Feedback, High Level Feedback, transducer Loss, Not Maintaining Setpoint, Loss of Prime, PUMp Over Cycle. Refer to parameters P4-07 and P4-08. The number of restart attempts is set by L5-01.	Overcurrent Ground Fault Output Phase Loss Input Phase Loss iQpump Overload
L5-03	20 s	Maximum Restart Time After Fault	If the restart fails (or is not attempted due to a continuing fault condition), iQpump waits the Maximum Restart Time After Fault before attempting another restart.	Motor Overload Overtorque DC Bus Fuse Blown DC Bus Undervoltage DC Bus Overvoltage Overheat
P1-06	40.0 Hz	Minimum Pump Frequency	Minimum speed (Hz) the pump has to operate at. Example: Base pump motor speed is 3600 RPM, minimum speed is 2400 RPM. Set minimum pump frequency to 40.0 Hz (2400 ÷ 3600 x 60 Hz = 40 Hz)	P1-06 should be set to the level where the pump can produce the minimum pressure even at zero flow.
P2-03	5 s	Sleep Delay Time	Time it takes before the pump system goes to sleep when the selected signal level (P2-01) falls below the specified sleep level (P2-02)	Adjust according to system requirements.
P4-05	30.0 Hz	Thrust Bearing Frequency	Sets the frequency reference used when the thrust bearing function is active. A value of 0 disables this function.	Primarily used for submersible pumps. Program P4-05 = 0.0 Hz to disable function when iQpump is used with a centrifugal pump. (See Figure 4.11)
P4-11	0.2 min	Utility Start Delay	When utility power is restored and P4-10 is enabled (1), iQpump waits the time specified in P4-11 before auto operation becomes active.	Note: Only active when P4-10 is enabled (1) and operation (start / stop) is from the digital operator.

1 TRANSDUCER / FEEDBACK DEVICE SCALING

P1-03 = 0 0 0 0 0 Feedback Scaling

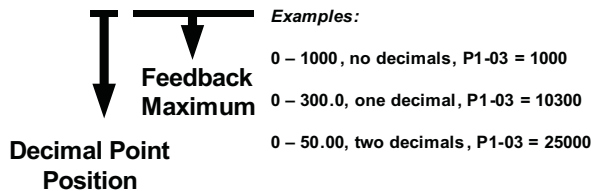
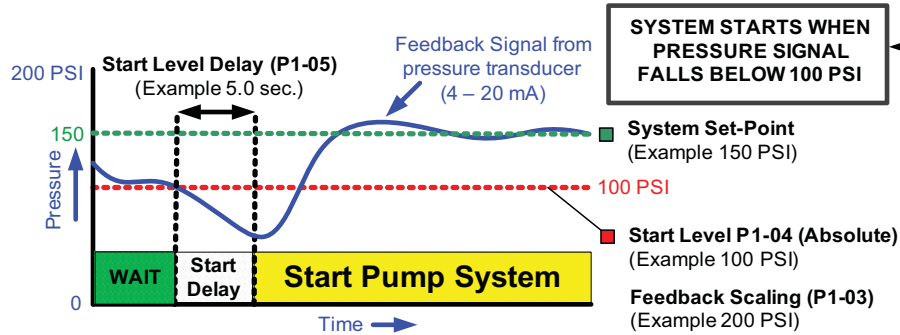

Figure 4.8

2 START LEVEL

Example: Absolute Level (Positive Start Level)



Example: Delta Level (Negative Start Level)

Note: When System Set-point is changed, the start level is automatically adjusted .

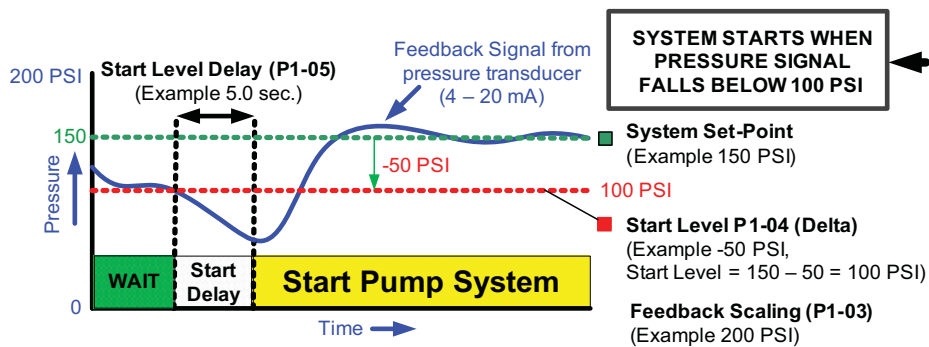

3 SLEEP MODE (Example)

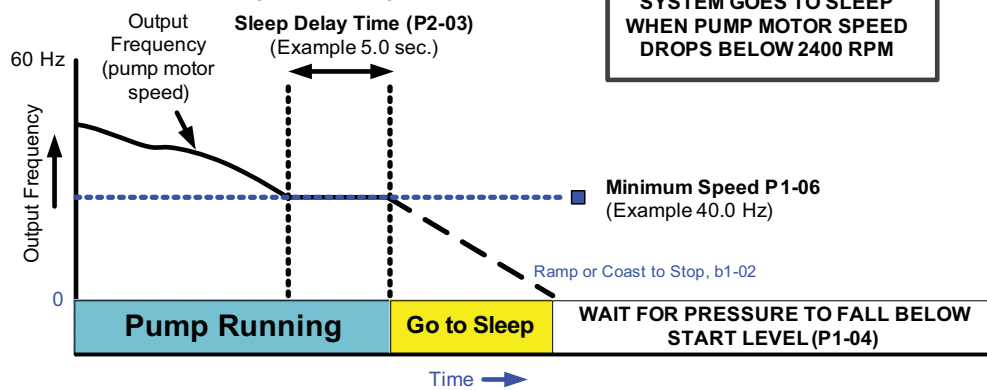



Figure 4.9

4 HAND MODE OPERATION

Hand Speed from the Keypad/Digital Operator (Default)

Press the HAND KEY on the digital operator to run the system in Hand Mode.

Hand Mode speed can be adjusted by pressing , use 

to move the cursor and   to adjust the hand speed reference.

 Press  save new active hand speed reference.

'0' Blinking

Hand Speed from Analog Input (0 – 10V)

Set parameter P 5-01 'Hand Mode Ref.' to '0' to adjust the hand mode reference from an external 0 – 10V signal connected to terminal A1 and AC.

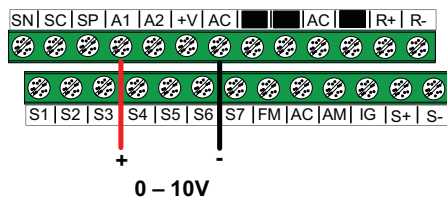

HAND KEY

Note: Hand Key can be disabled with parameter P 5-04

Figure 4.10

5 THRUST BEARING - SUBMERSIBLE MOTORS (e.g. Franklin)

Note: Thrust Bearing Function is Enabled by Default

When **using** a submersible motor in combination with iQpump, it is recommended to use the **Thrust Bearing** function to prevent excess motor wear. To enable this function, enter the minimum motor frequency in parameter P4-05. Example: Minimum motor speed 1800 RPM, $1800 \text{ RPM} \div 3600 \text{ RPM} \times 60.0 \text{ Hz} = 30.0 \text{ Hz}$

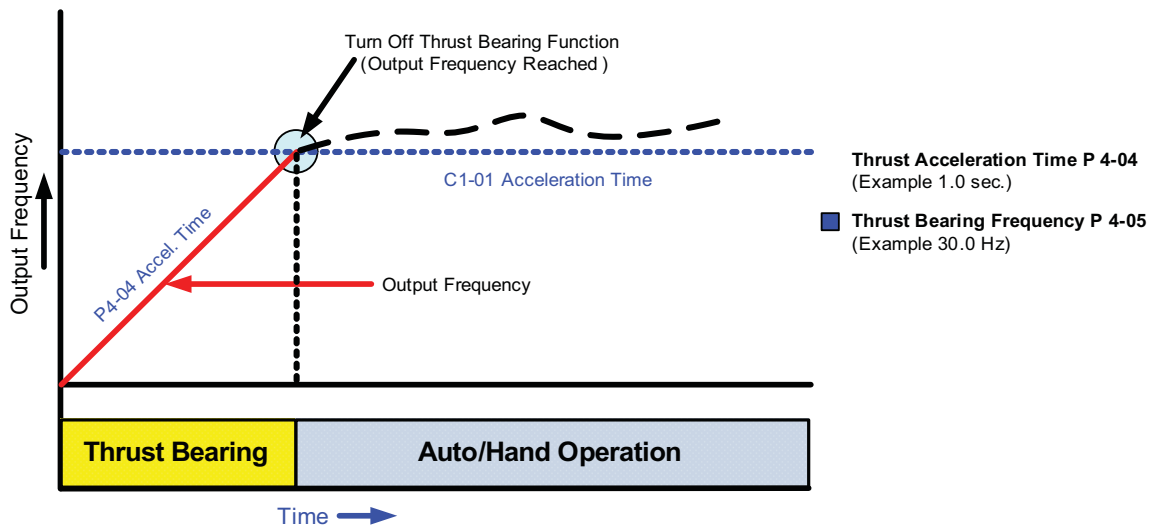

Figure 4.11

4.2 iQpump Drive Quick Start-Up Procedures

■ Auto Operation - Power Down Storage

Allows iQpump to automatically start after power failure when operated from keypad / digital operator. This function is recommended for use when operating the iQpump in remote / unmanned areas.

⚠ WARNING

SUDDEN MOVEMENT HAZARD

When the iQpump is powered down while running, an internal run command will automatically be initiated upon power-up. Clear all personnel from the vicinity of moving equipment before system power-up.

◆ Step # 6 - Pump Rotation and Feedback Signal Check



When Pump Quick Set-up is completed, press to exit the Pump Quick Set-up menu and go to operation.

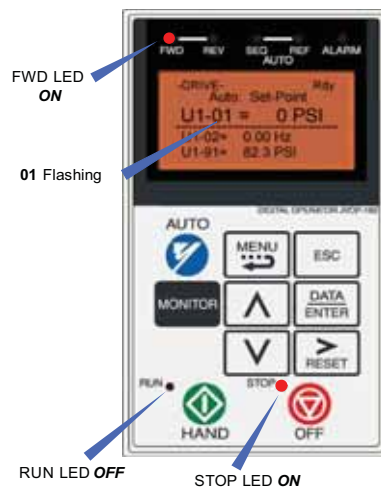

In this step the pump motor is checked for proper direction and operation. This test is to be performed solely from the digital operator. Apply power to the iQpump drive after all the electrical connections have been made and the terminal cover has been reattached. At this point, the digital operator should display as shown in the *Figure 4.12*.

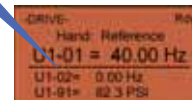

Next, push  on the digital operator; the display should read



Hand reference speed can be adjusted by pressing , use  to move cursor

and   to adjust the value. Press  to save changes.

The motor should now be operating at low speed in the correct direction of pump.

RUN ● LED should be **ON**.

Push  on the digital operator; the display should read as in Fig. 3.
OFF

If the direction is not correct, then power down the iQpump.

⚠ DANGER, LETHAL VOLTAGES ARE PRESENT Before applying power to the iQpump, ensure that the terminal cover is fastened and all wiring connections are secure. After the power has been turned OFF, wait at least five minutes, until the charge indicator extinguishes completely before touching any wiring, circuit boards or components.

Using Safety precaution, and referring to *Fig.1 or 2*, swap any **two** of the **three** output leads to the pump motor (U/T1, V/T2 and W/T3). After the wiring change repeat **Step 6** and recheck motor direction.

Figure 4.12

■ **Feedback Signal Check**

Verify the feedback signal level the drive keypad display matches the mechanical pressure gauge. Refer to parameters P1-02 and P1-03, if the feedback device scaling or system units are incorrect.

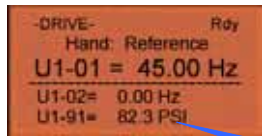

FEEDBACK SIGNAL LEVEL

◆ **Step # 7 - Auto Mode Operation**

The iQpump drive can be operated in automatic mode when the following actions are performed:

- All parameters are programmed
- Pump motor direction is verified
- Feedback signal is verified

At this point, the digital operator should display as shown in *Figure 4.13*.





Figure 4.13 Digital Operator

■ **Set System Setpoint**

Next, press  to access or modify the system set -point that was entered using parameter d1-01 System Set-point in the Pump Quick Setup Menu

Use  to select the digit and   to change the system set -point.

Next press  to store set -point and press  to return to the main operation menu.



Example: 80 PSI

Next, press the **AUTO** button to start the iQpump.

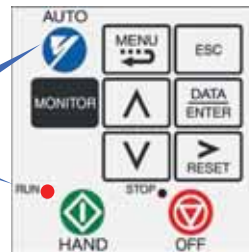

4.2 iQpump Drive Quick Start-Up Procedures

iQpump automatically starts in Auto Mode when the feedback signal level falls below the programmed level in parameter P1-04 for the specified time in P1-05, Refer to [Figure 4.14](#).

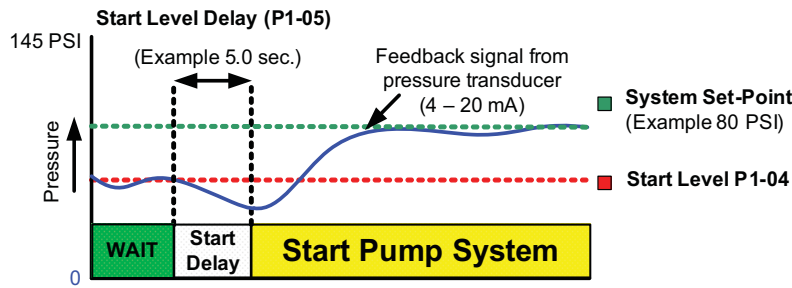

Figure 4.14 Start Pump System

■ Sleep and Anti-No-Flow (ANF) Detection (P2-23, P2-24, P2-25)

Note: Ensure the system is regulating properly under normal running conditions before adjusting Anti-No-Flow operation. If the system is stable, continue to Step 1 to verify no-flow/sleep operation. If the system is unstable, turn off the Anti-No-Flow function (P2-23 set to 0.00%) and adjust the PI-control parameters b5-02, b5-03 to stabilize system. Once the system is stable, re-enable the Anti-No-Flow function by setting P2-23 back to 0.40% and continue to Step 1 to verify no-flow/sleep operation.

1. Create a no-flow situation (e.g., close off the discharge valve) to verify that the system holds pressure.
2. Press the STOP button on the digital operator and wait 1 minute until the system stabilizes then verify system pressure feedback in U1-91. If the pressure drops more than 3 psi, adjust P2-25 to the actual delta pressure drop plus 1 psi.
Example: If the setpoint is 80 psi and U1-91 shows 76 psi then P2-25 should be $4 + 1 = 5$ psi. This sum value should always be more than the start level (P1-04). If this sum value is not more than the start level, the system pressure is not holding and should be corrected or the pump system will continue to cycle on and off.
3. Run system in normal automatic operation with flow and check monitor U1-99 to verify that the value is continuously incrementing and resetting back to zero. If the value holds at 10 seconds, increase P2-24 by increments of 5 seconds. Repeat this process each time P2-24 is adjusted.
4. Create a no-flow situation and ensure that U1-99 increments and holds at the time set in P2-24. When the Anti-No-Flow timer expires, the speed will gradually reduce until it reaches the minimum pump speed (P1-06). The speed will hold at the minimum pump speed for 5 seconds before going to sleep.
5. Run system in normal automatic operation and verify sleep and wake-up operation until reaching satisfactory system performance.

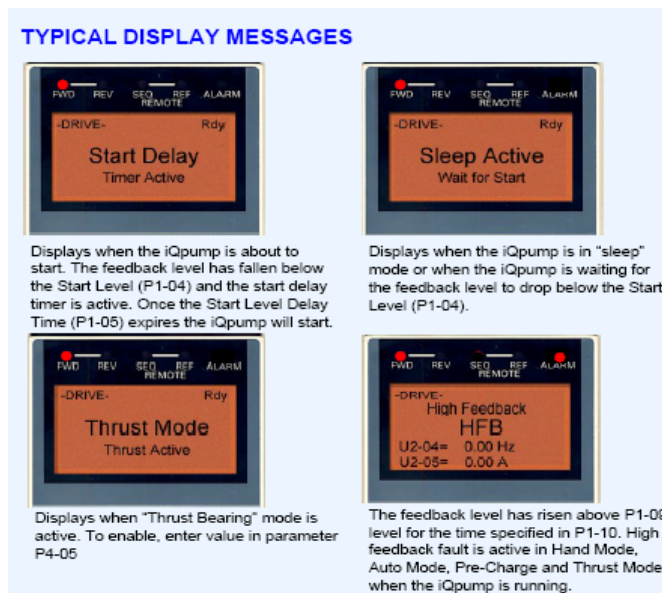

Figure 4.15 Display Messages

◆ Simplex Pump Setup Complete

This completes the quick setup procedure required to configure the iQpump Drive for simplex pump operation.



Basic Programming

This Manual contains descriptions of all user accessible parameters contained in the iQpump drive. Parameters are listed in alpha-numerical order. Parameter number and name, along with a detailed description and its settings are described on the following pages.

5.1 iQpump Basic Programming Parameters	90
5.2 Pump Basic	128
5.3 Pump Protection	131
5.4 T1 Auto Tuning	135

5.1 iQpump Drive Basic Programming Parameters

The initialization group contains parameters associated with initial set-up of the iQpump drive. Parameters involving the display language, access levels, initialization and password are located in this group.

◆ A1 Initialization

■ A1-01 Access Level Selection

Setting	Description
0	Operation Only
2	Advanced Level (<i>factory default</i>)

If the iQpump drive is programmed for Operation Only (A1-01 = “0: Operation Only”), then only the Operation and Programming menus are accessible. Within the Programming menu, only parameters A1-01 and A1-04 are adjustable.

If A1-01 is configured for Advanced Access (A1-01 = “2: Advanced Level”), then all menus and all parameters are shown. If the Access Level Selection is set to Advanced, all parameters should be adjustable unless:

1. The iQpump drive parameters are password protected (A1-04), preventing access to A1-00 through A1-03 and all A2 parameters.
2. A digital input configured as a Program Lockout (H1-0x = 1B) is active.
3. During serial communication writing, if a parameter change is also attempted via the digital operator, a “BUSY - WRITE PROTECTED” message will display. Parameter change will not be possible from the digital operator until an Enter command is received via the serial communication to finish the serial writing process.

■ A1-03 Initialize Parameters

Setting	Description
0	No Initialize (<i>factory default</i>)
1110	User Initialize
2220	2-Wire Initialize
3330	3-Wire Initialize

The iQpump drive can be set to one of three default states via parameter A1-0.

1. User Initialization – 1110: The modified iQpump drive parameters are returned to the values selected as user settings. User settings are stored when parameter o2-03 = “1: Set Defaults.”
1. 2-Wire Initialization – 2220: The iQpump drive parameters are returned to factory default values with digital inputs S1 and S2 configured as Forward Run and Reverse Run, respectively.
1. 3-Wire Initialization – 3330: The iQpump drive parameters are returned to factory default values with digital inputs S1, S2, and S5 configured as Run, Stop, and Forward / Reverse respectively.

After an initialization is performed, parameter A1-03 will automatically reset to 0.

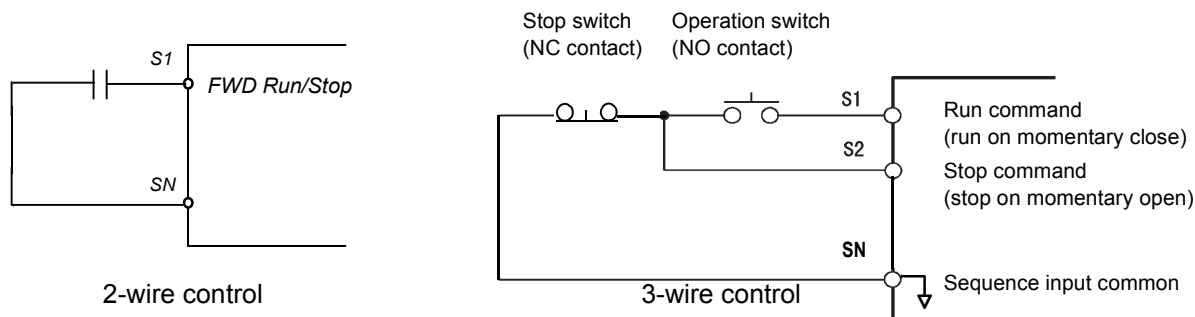

Figure 5.1 2 & 3-Wire Control Wiring Examples

Important: Some parameters are unaffected by either the 2-Wire or 3-Wire initialization. The following parameters will not be reset when parameter A1-03 = 2220 or 3330:

- A1-00, Language Selection
- E1-03, V/f Pattern Selection
- o2-04, kVA Selection

◆ b1 Sequence

The Sequence Group contains parameters associated with starting and stopping the iQpump drive. Parameters involving the Run Command, Speed Reference and Setpoint location, Stopping Method and Hand / Auto changeover are located in this group.

■ b1-01 Frequency Reference Selection

Setting	Description
0	Operator - Digital Preset Speed d1-01 (<i>factory default</i>)
1	Terminals - Analog Input Terminal A1 (or Terminal A2, see Parameter H3-13)
2	Serial Com - RS-485 Terminals R+, R-, S+ and S-
3	Option PCB - Option Board connected at 2CN

In order to run the iQpump drive and motor, the iQpump drive must receive a Run command and a Auto Setpoint command. Parameter b1-01 specifies from where the Auto setpoint is received when in the “Auto” mode. Switching into the “Auto” mode can be done by pressing the AUTO button on the digital operator while the iQpump drive is stopped.

Important: If a Run command is input to the iQpump drive but no corresponding Auto setpoint is input, the Run indicator on the digital operator will turn on and the STOP indicator on the digital operator will blink.

If the iQpump drive should follow the “Hand Reference” set by the digital operator: Use the “Hand” mode by pressing the hand key and set P5-01 = “1: Hand Reference (P5-02).” The hand reference can then be entered into the U1-01 monitor parameter in the “-DRIVE-” Menu.

The iQpump drive offers the ability to provide four types of “Auto Setpoint” reference sources. These Auto Setpoint reference sources are determined by the setting of b1-01 and the drive set to “Auto” mode by pressing the Auto key on the digital operation.

Note: Prior to programming, it is recommended to first select the system units (P1-02) and the feedback device, Scaling (P1-03). P1-03 will automatically scale the iQpump setpoint.

Example:

P1-02 = 1: psi

P1-03 = 200, feedback range = 200 psi.

If the iQpump drive should follow an “Auto Set-Point” set by the digital operator: Set b1-01 = “0: Operator” (factory default), The Auto setpoint can then be entered into the U1-01 monitor parameter in the “-DRIVE-” menu.

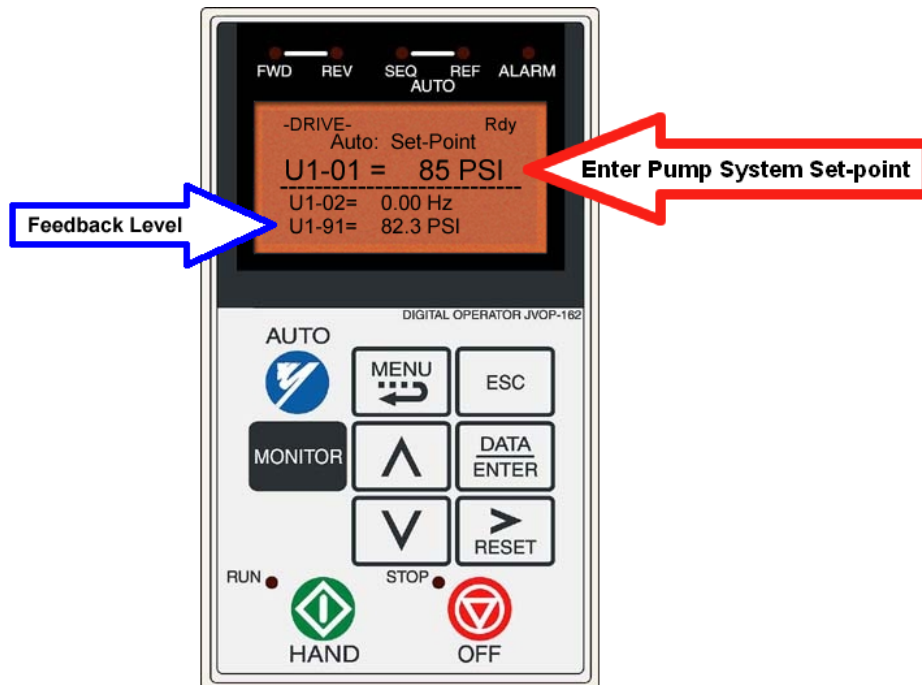

Figure 5.2 Digital Operator Auto Setpoint

If you want the iQpump drive to follow an “Auto Setpoint” set by the analog input: Set b1-01 = “1: Terminals,” and connect a potentiometer or external signal to the iQpump drive. Refer to [Figure 5.3](#) for connection diagram for the setpoint potentiometer.

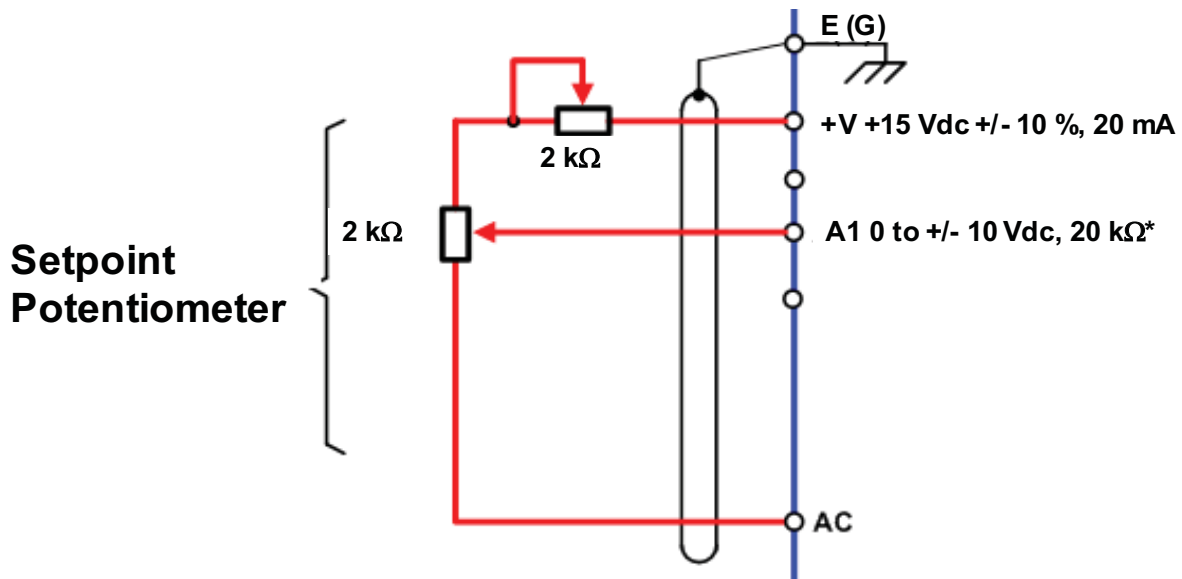

Figure 5.3 Setpoint Potentiometer Connection Diagram

Refer to [Figure 5.4](#) for the connection diagram for an external analog signal setpoint reference.

Note: When b1-01 = 1 (terminals) and P5-01 = 0 (hand mode reference source), the setpoint and the hand reference are determined by the external analog signal.

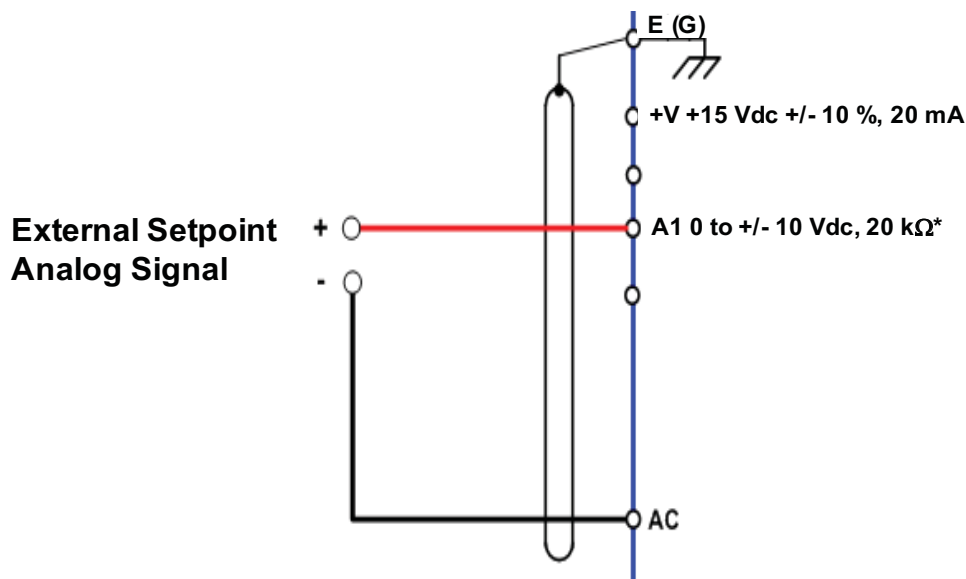

Figure 5.4 External Analog Signal Setpoint Reference

If you want the iQpump drive to receive the “Auto Setpoint” from serial communication: Set b1-01 = “2: Serial Com,” and connect the RS-485 / 422 serial communications cable to terminals R+, R-, S+, and S- on the control I/O terminal block.

Refer to [Figure 5.5](#) for the connection diagram using a PC to provide the auto setpoint reference to the iQpump drive. Further information regarding Modbus address and communication protocols [Refer to Parameters on page 165](#) and Appendix: D .

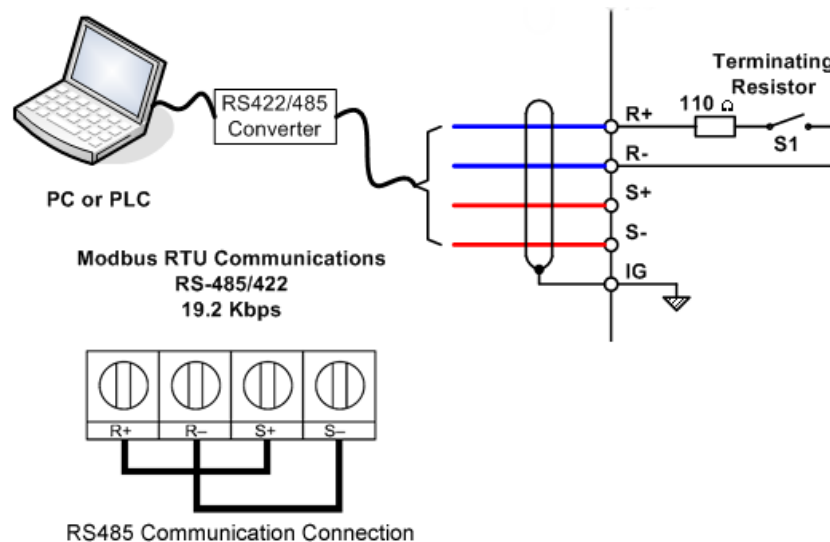

Figure 5.5 Connection Diagram of PC or PLC

If you want the iQpump drive to receive the “Auto Setpoint” for a network communication option card: Set b1-01 = “3: Option PCB”, and plug a network option board (p/n SI-J) into the 2CN port on the iQpump drive Control PCB. Consult the manual supplied with the option board for instructions on integrating the iQpump drive into the network system.

The iQpump drive can support the following network communication options. Refer to the appropriate Installation Guide (IG) and Technical Manual (TM) for further details. These network communications documents can be located at <http://iQpump.yaskawa.com>.

- | | |
|-------------------------------------|-------------------|
| • Profibus DP Option Card CM061 | Manual: IG.AFD.12 |
| • DeviceNet Option Card CM05X | Manual: IG.AFD.14 |
| • Modbus Plus Option Card CM071 | Manual: IG.AFD.17 |
| • Modbus TCP / IP Option Card CM090 | Manual: IG.AFD.25 |
| • EtherNet / IP Option Card CM092 | Manual: IG.AFD.26 |

5.1 iQpump Drive Basic Programming Parameters

Important: If b1-01 = “3: Option PCB” but a network card is not installed in 2CN, an OPE05 Operator Programming Error will be displayed on the digital operator and the iQpump drive will not run.

■ b1-02 Run Source

Setting	Description
0	Operator (<i>factory default</i>)
1	Terminals
2	Serial Com
3	Option PCB
5	Timed Run <0034>

■ Start / Stop from Keypad (Parameter b1-02 = 0)

The iQpump drive comes factory programmed for Start and Stop from the Keypad.

The iQpump drive can be programmed to receiver a Run command from four different inputs: digital operator, terminals, serial communications, or an option PCB.

If the Run command input is determined by the digital operator: Set b1-02 = “0: Operator,” and the hand key will be used to provide the Run command to the iQpump drive.

If the Run command input is determined by the external terminals: Set b1-02 = “1: Terminals” and initiate an external Run command by a contact closure between terminals S1 and SN. Refer to [Figure 5.6](#) for the connection diagram of the external Run command.

Note: To use the external terminals requires the iQpump drive to be set to “Auto” mode by pressing the Auto key.

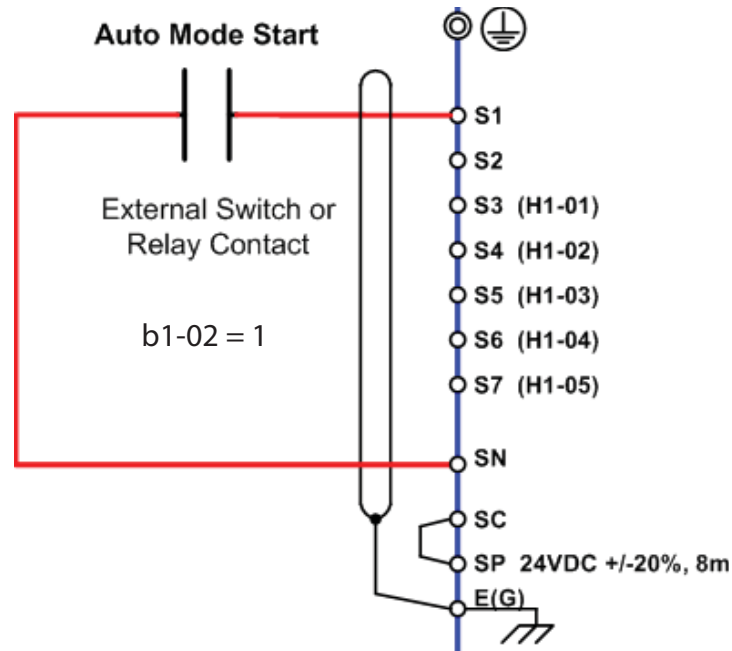

Figure 5.6 Connection Diagram of External Start / Stop Switch

If the Run command is determined by Serial Communications: b1-02 = “2: Serial Communications,” and initiate the Run command through the serial communications. Refer to [Figure 5.5](#) (in the previous b1 sequence section) for the connection diagram for serial communications through the RS232 / 485 terminals. The following is a simple setup procedure for programming the iQpump drive and PC Serial communications to initiate Run and Stop commands through serial communications. Appendix: E has further details on the Modbus communications.

1. Program b1-02 = “2: Serial communications.”
2. Program the following H5 parameters:
 - H5-01 Serial Communication Address: 31
 - H5-02 Serial Baud Rate: 9600 Baud (setting 3).
 - H5-03 Serial Communication Parity Selection: None (setting 0).

3. Initiate a Start / Stop command

iQpump command register number: 0001

Stop Command: Transmit value of **0000** (16 bit) to iQpump command address.

Start Command: Transmit value of **0001** (16 bit) to iQpump command address.

Reset Command: Transmit value of **0008** (16 bit) to iQpump command address.

If the Run command input is determined by a network communications option PCB: b1-02 = “3: Option PCB,” and initiate the Run command through the available network communications option PCB listed below. The Installation Guides (IG) and Technical Manuals (TM) are available at <http://iQpump.yaskawa.com>.

The iQpump drive allows for monitoring, diagnostics and control using any of the following communication option cards:

- Profibus DP Option Card CM061 Manual: IG.AFD.12
- DeviceNet Option Card CM05X Manual: IG.AFD.14
- Modbus Plus Option Card CM071 Manual: IG.AFD.17
- Modbus TCP / IP Option Card CM090 Manual: IG.AFD.25
- EtherNet / IP Option Card CM092 Manual: IG.AFD.26

Note: Refer to the [communication card instruction manual](#) or consult factory for installation and operation instructions.

■ Start / Stop from Comm. Option Card (Parameter b1-01 = 3):

The iQpump drive allows for the setpoint reference to be set via any of the following communication option cards:

- | | |
|-------------------------------------|-------------------|
| • Profibus DP Option Card CM061 | Manual: IG.AFD.12 |
| • DeviceNet Option Card CM05X | Manual: IG.AFD.14 |
| • Modbus Plus Option Card CM071 | Manual: IG.AFD.17 |
| • Modbus TCP / IP Option Card CM090 | Manual: IG.AFD.25 |
| • EtherNet / IP Option Card CM092 | Manual: IG.AFD.26 |

■ Feedback Device

The iQpump drive requires a feedback device (e.g. Pressure transducer, flow meter, etc.) to perform automatic system regulation. Any analog 0~10V or 4-20mA feedback device can be used in combination with the iQpump drive.

Connecting Your Feedback Device to the iQpump Drive

Note: The factory default setting for the iQpump drive is 4~20mA feedback device connected to analog input A2.

To successfully operate the iQpump drive remotely, an external run command must be received by the iQpump drive. Parameter b1-02 specifies from where the run command will be accepted.

Although the Run Source and the Reference Source (b1-01) are normally taken from the same source (e.g. digital operator, terminals or serial communication), this is not always the case.

To issue a run command from the digital operator: Set b1-02 = “0: Operator,” and use the HAND and OFF buttons to start and stop the iQpump drive.

To issue the run command from the terminals: Set b1-02 = “1: Terminals,” and select between 2-wire and 3-wire control operation by doing the following:

2-Wire Control The factory default setting is for 2-wire operation. In the 2-wire configuration a closure between S1 and SN will be interpreted as a Forward Run command by the iQpump drive.

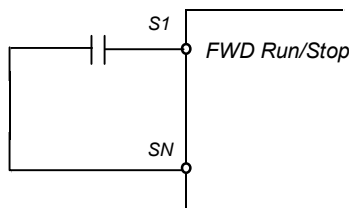

Figure 5.7 2-Wire Control

3-Wire Control When any of the multi-function digital input parameters, H1-01 through H1-05, is set to 0, terminals S1 and S2 become Run and Stop, respectively. The multi-function digital input that was set to 0 will function as a Forward / Reverse input for the iQpump



5.1 iQpump Drive Basic Programming Parameters

drive. When the Forward / Reverse input is open the iQpump drive will run in the Forward direction and when the input is closed, the iQpump drive will run in the Reverse direction.

In 3-wire operation a momentary closure (> 50 mS) of S1 will cause the iQpump drive to run provided that S2 is held closed. The iQpump drive will stop anytime the S2-SN connection is broken. If the 3-wire configuration is implemented via a 3-wire Initialization (A1-03 = “3330: 3-Wire Initial”), then terminal S5 becomes the Forward / Reverse input.

Note: Reverse operation is disabled in the iQpump drive; however, in 3-wire control, one of the multi-function digital inputs needs to be programmed to 0. Otherwise, the 3-wire control will not work.

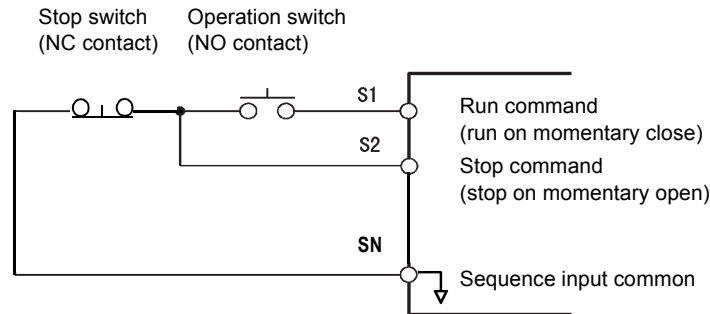

Figure 5.8 3-Wire Control

To issue a Run command via serial communication: Set b1-02 = “2: Serial Com” and connect the RS-485 / 422 serial communication cable to R+, R-, S+, and S- on the removable terminal block.

To issue the Run command via the network option card: Set b1-02 = “3: Option PCB”, and plug a network option board (p/n SI/J) into the 2CN port on the Control PCB. Consult the manual supplied with the option board for instructions on integrating the iQpump drive into your network System.

Important: If b1-01 = “3: Option PCB” but a network card is not installed in 2CN, an “OPE05” operator programming error will be displayed on the digital operator and the iQpump drive will not run.

■ b1-03 Stopping Method

There are four methods of stopping the iQpump drive when the Run command is removed.

Setting	Description
0	Ramp to Stop (<i>factory default</i>)
1	Coast to Stop
2	DC Injection to Stop
3	Coast w / Timer

0: Ramp to stop: When the Run command is removed, the iQpump drive will decelerate the motor to 0 rpm. The rate of deceleration is determined by the active deceleration time. The factory default Decel Time is in parameter C1-02.

When the output frequency has dropped below the DC Injection Start Frequency in b2-01 (Default = 0.5 Hz) DC current will be injected in the motor at a level determined by b2-02 (50 % Default). The DC Injection condition will occur for the time specified by b2-04 (0.0 Default), to establish the end point of the ramp. DC injection can be used to insure the motor is at zero rpm prior to the iQpump drive shutting off.

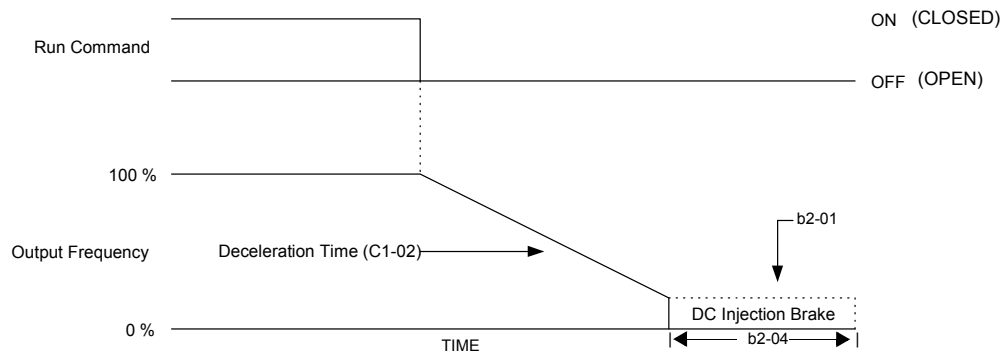

Figure 5.9 Deceleration to Stop

The actual deceleration time can be determined by the following formula.

$$\text{Time to Stop} = \frac{\text{Output Freq. at time of stop command}}{\text{Maximum Frequency (E1-04)}} \times \text{Setting of active Decel Time (C1-02 or C1-04)}$$

If S-Curve characteristics are specified by the iQpump drive programming, they will add to the total time to stop.

1: Coast to Stop: When the Run command is removed, the iQpump drive will turn off its output and the motor will coast (uncontrolled deceleration). The friction of the driven equipment will eventually overcome any residual inertia of the system and the rotation will stop.

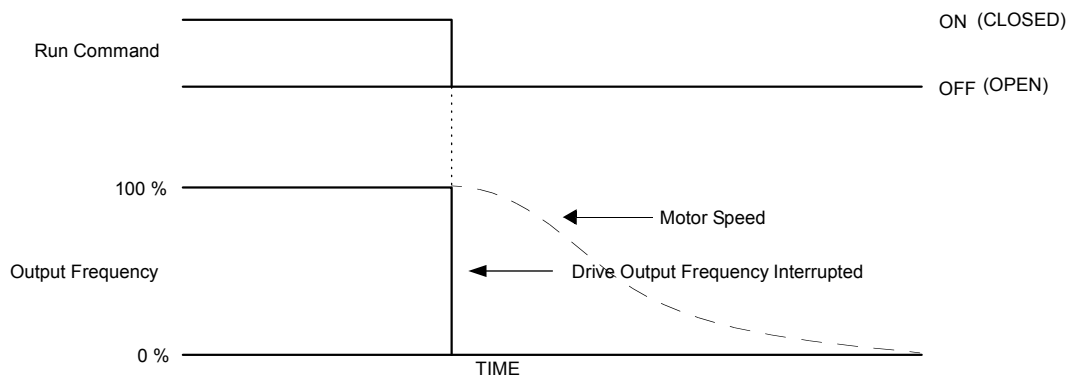

Figure 5.10 Coast to Stop

Important: After a stop is initiated, a subsequent Run commands input before the Minimum Baseblock Time (L2-03) has expired, will be ignored.

2: DC Injection to Stop: When the Run command is removed, the iQpump drive will Baseblock (turn off its output) for the Minimum Baseblock Time (L2-03). Once the Minimum Baseblock Time has expired, the iQpump drive will inject DC current into the motor windings to lock the motor shaft. The stopping time will be reduced as compared to Coast to Stop. The level of DC Injection current is set by parameter b2-02 (50 % Default). The DC Injection brake time is determined by the set value in b2-04 and the output frequency at the time the Run command is removed.

$$\text{DC Injection Brake Time} = \frac{(b2 - 04) \times 10 \times \text{Output Frequency}}{\text{Maximum Frequency (E1 - 04)}}$$

5.1 iQpump Drive Basic Programming Parameters

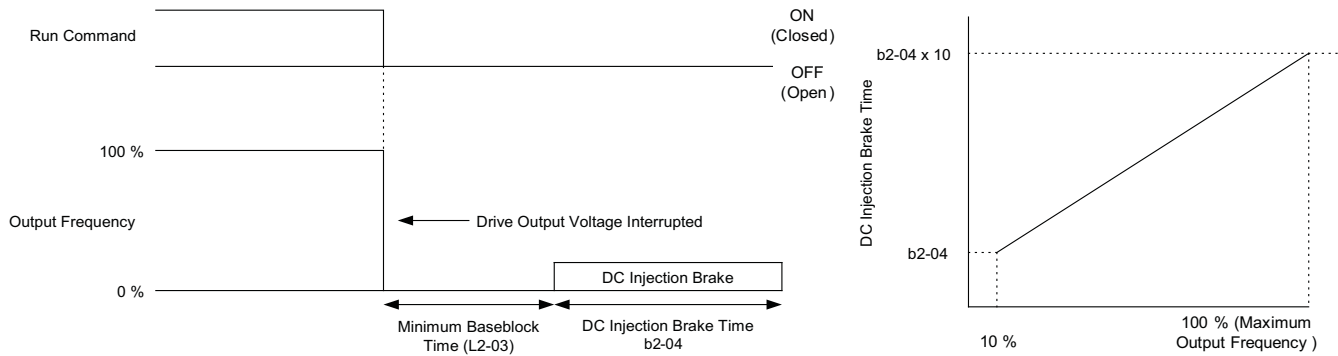

Figure 5.11 DC Injection Braking to Stop

Important: If an overcurrent (OC) fault occurs during DCInj to Stop, lengthen the Minimum Baseblock Time (L2-03) until the fault no longer occurs.

3: Coast to Stop with Timer: When the Run command is removed, the iQpump drive will turn off its output and the motor will coast to a stop. If a Run command is input before time T (operation wait time) expires, the iQpump drive will not run and the Run command will need to be cycled before operation can occur. The time T (operation wait time) is determined by the output frequency when the Run command is removed and the active deceleration time (C1-02).

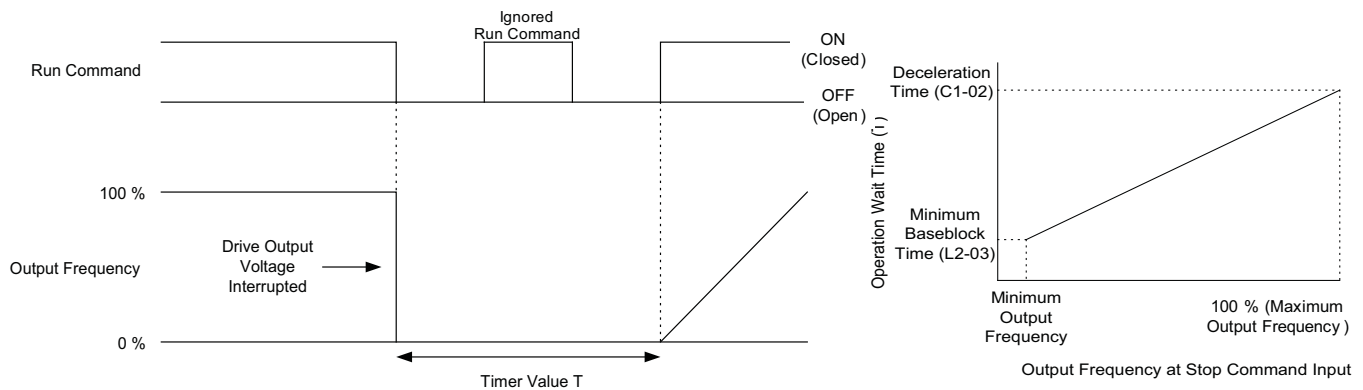

Figure 5.12 Coast to Stop with Timer

◆ b2 DC Braking

The DC Braking Group contains parameters associated with the DC Injection Braking feature. Parameters involving the starting frequency, current level, braking time, and motor pre-heat current level are located here.

■ b2-01 DC Injection Braking Start Frequency

Setting Range: 0.0 ~ 10.0 Hz

Factory Default: 0.5 Hz

Parameter b2-01 sets the output frequency where the iQpump drive begins DC Injection during Ramp to Stop in order to lock the rotor of the motor and establish the end point of the ramp. If $b2-01 < E1-09$ (Minimum Frequency), then DC Injection begins at E1-09.

Parameter b2-01 also determines the output frequency that the iQpump drive must be at or below before a Zero Speed condition is considered true. This affects any digital output configured as a Zero Speed signal (H2-0x = "1: Zero Speed").

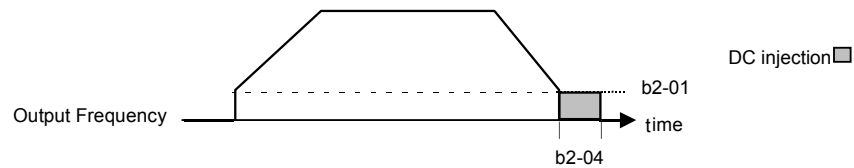

Figure 5.13 DC Injection Braking During Stopping

■ b2-02 DC Injection Braking Current

Setting Range: 0 ~ 100 %
Factory Default: 50 %

The level of DC Injection Braking Current affects the strength of the magnetic field attempting to lock the motor shaft. Increasing the level of current will increase the amount of heat generated by the motor windings and should only be increased to the level necessary to hold the motor shaft. DC Injection current is set in percentage of iQpump drive rated output current. The iQpump drive rated output current is stated on the iQpump drive nameplate.

■ b2-03 DC Injection Braking Time at Start b2-04 DC Injection Braking Time at Stop

Setting Range: 0.00 ~ 10.00 s
Factory Default: b2-03 = 0.00 s
b2-04 = 0.00 s

The iQpump drive can be programmed to automatically DC Inject for a predetermined amount of time prior to accelerating to speed (b2-03) and / or at the end of a Ramp to stop (b2-04). Parameter b2-03 can be used to stop a rotating motor prior to attempting acceleration (i.e. a wind milling fan). If DC Injection braking at start or Speed Search is not enabled, attempting to iQpump drive a spinning motor may cause nuisance tripping.

Parameter b2-04 can be used to resist any residual motion of the load after the deceleration has finished.

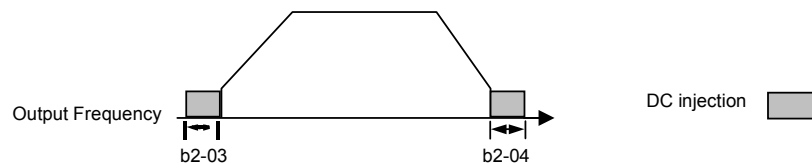

Figure 5.14 DC Injection Braking During Starting and Stopping

Parameter b2-04 also affects the length of time DC Injection to Stop (b1-03 = “2: DC Injection to Stop”) will occur.

■ b2-09 Motor Pre-Heat Current

Setting Range: 0 ~ 100 %
Factory Default: 0 %

A DC current can be circulated within the motor windings while the motor is stopped. The current will produce heat within the motor and prevent condensation. Parameter b2-09 determines the percentage of iQpump drive rated output current that will be used for the motor pre-heat function. This function can be useful in applications where the motor sits for extended periods of time in humid conditions. Motor pre-heating can only be initiated by closing a digital input programmed as a Motor Pre-heat Input (H1-0x = 60). Check with the motor manufacturer to determine the maximum acceptable current level the motor can withstand when stopped. Be sure not to exceed the motor manufacturers recommended level.

Pump Tuning

◆ PI Control Tuning (b5 Group)

The built-in PI controller in the iQpump is used to control process variables such as pressure, flow or fluid level. PI control is designed to eliminate the need for continuous operator attention. The drive has the capability to accept an analog signal 0-10 Vdc or 4-20 mA as feedback for a PI (Proportional + Integral) control function. A process reference setpoint is connected to the iQpump drive or set via the digital operator and an actual process value feedback is also brought back to the iQpump drive.

Examples:

Whether the iQpump is used in either Simplex (P1-03 = 0) or Multiplex mode (P1-01 = 1 or 2); the PI settings will need to be adjusted based on individual system applications. The three parameters below should be the only adjustments required. If control becomes unstable, please refer to the PI Control (b5-xx) for more details.

Note: These parameters are also programmed through the quick start menu.

Step 1. Make sure that PI is enabled (factory default is enabled b5-01 = 1).

◆ b5-01 PI Mode

Setting	Description
0	Disabled
1	Enabled (<i>factory default</i>)
2	Fref + PI

The iQpump drive can be used as a stand-alone PI controller. If PI functionality is selected by parameter b5-01, the iQpump drive will adjust its output to cause the feedback from a transmitter to match the PI Setpoint (b5-19). The setting of b5-01 will determine whether PI functionality is disabled (b5-01 = “0: Disabled”), enabled (b5-01 = “1: Enabled”).

Step 2. Adjust Proportional Gain Setting.

◆ b5-02 Proportional Gain Setting

Setting Range: 0.00 ~ 25.00

Factory Default: 2.00

The proportional gain will apply a straight multiplier to the calculated difference (error) between the PI Setpoint and the measured transmitter feedback at terminal A2. A large value will tend to reduce the error but may cause instability (oscillations) if too high. A small value may allow too much offset between the setpoint and feedback (see [Figure 6](#)).

Step 3. Adjust Integral Time

◆ b5-03 Integral Time Setting

Setting Range: 0.0 ~ 360.0 s

Factory Default: 3.0 s

The Integral factor of PI functionality is a time-based gain that can be used to eliminate the error (difference between the setpoint and feedback at steady state). The smaller the Integral Time set into b5-03, the more aggressive the Integral factor will be. To turn off the Integral Time, set b5-03 = 0.0 seconds.

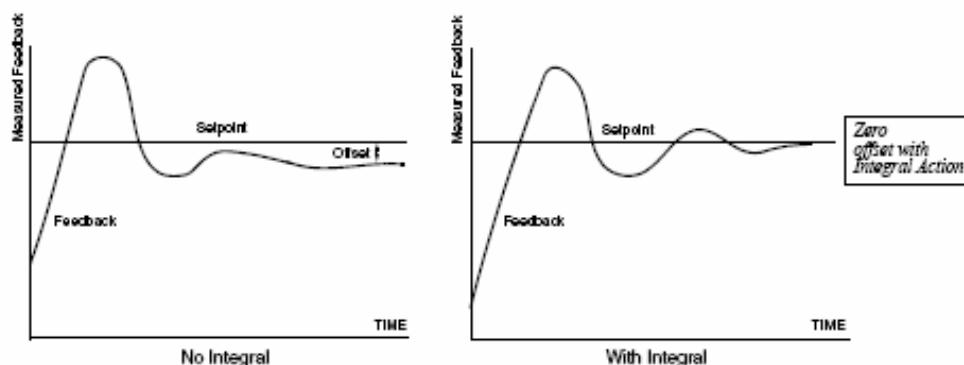

Figure 6. PI Feedback Response Characteristics

Speed Command / PI Setpoint

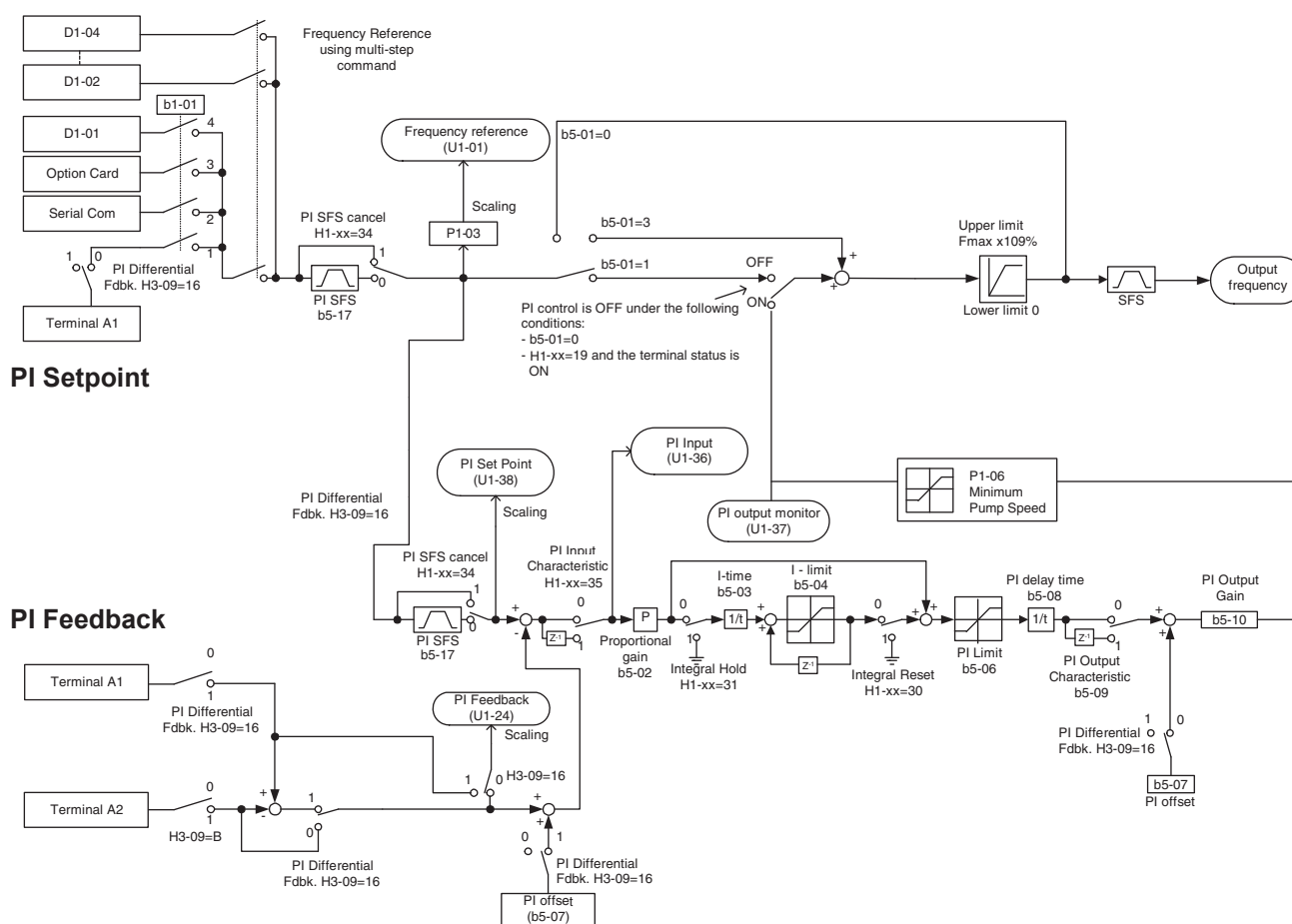

Figure 5.1 PI Block Diagram

The analog feedback to the iQpump drive for the PI control is via the A2 terminal. The iQpump drive must be programmed (H3-09 = “B: PI Feedback”) to use terminal A2 as feedback for the PI functionality of the iQpump drive.

The PI setpoint can be configured to come from one of many different inputs or parameters. *Table 5.1 on page 102* describes the options for originating the PI setpoint.

Table 5.1 PI Setpoint Options

The PI Setpoint will be read from:	If these conditions are true		
	Status of b5-18 =	Status of Modbus Register 0Fh bit 1	Status of b1-01 =
Parameter b5-19	1	N/A	N/A
Modbus Register 06H	0	ON	N/A
d1-01	0	OFF	0
Terminal A1	0	OFF	1
Serial Comm.	0	OFF	2
Option PCB	0	OFF	3

In some situations there are two feedback inputs. The iQpump drive can be programmed to maintain a set differential between two analog signals. If input A2 is configured as a “PI Differential Mode” (H3-09 = “16: PI Differential”), then the iQpump drive will maintain a set difference between the measurements read on inputs A1 and A2. This differential setpoint is programmed by parameter (b5-07).

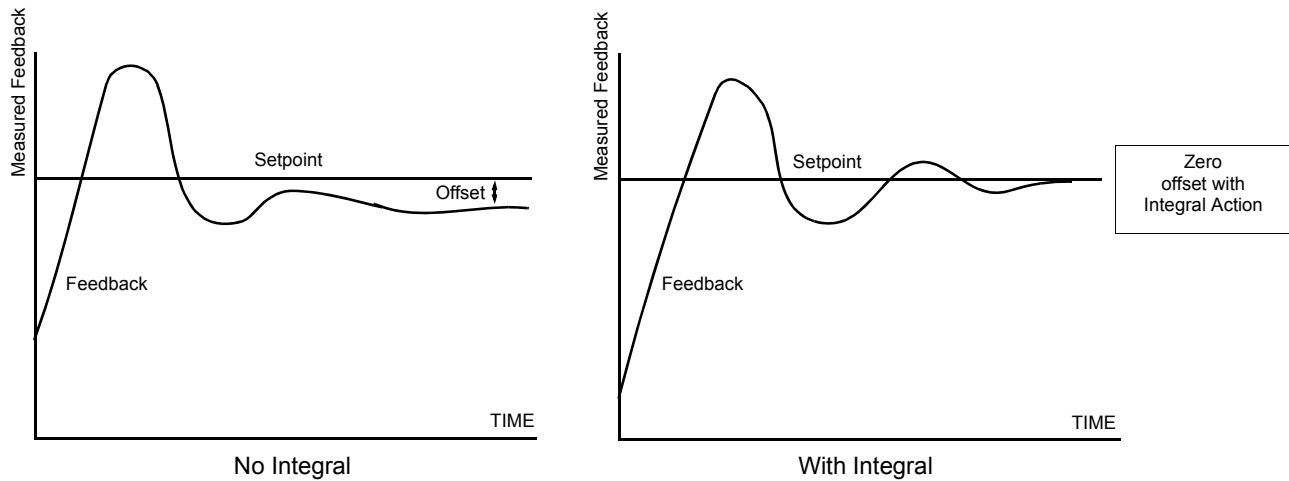

Figure 5.2 PI Feedback Response Characteristics

■ **b5-04 Integral Limit Setting**

Setting Range: 0.0 ~ 100.0 %
 Factory Default: 100.0 %

On some applications, especially those with rapidly varying loads, the output of the PI function may have large oscillations. To suppress these oscillations, a limit can be applied to the integral factor by programming b5-04.

■ **b5-06 PI Output Limit**

Setting Range: 0.0 ~ 100.0 %
 Factory Default: 100.0 %

Places a cap on the output of the PI function. Limiting the PI function may help to prevent large overshoots in the iQpump drive’s response to error (the difference between the setpoint and the feedback).

■ **b5-07 PI Offset Adjustment**

Setting Range: -100.0 % ~ +100.0 %
 Factory Default: 0.0 %

The PI Offset Adjustment parameter has two different uses. Parameter b5-07 serves different functions depending on whether it is used on a Standard PI loop or a Differential PI loop.

Parameter b5-07 causes an offset to be applied to the output of the PI function in a non-Differential PI loop. Every time the PI output is updated, the offset (b5-07) is summed with the PI output. This can be used to artificially kick-start a slow starting PI loop.

If the iQpump drive is configured for Differential PI Regulation (H3-09 = “16: PI differential”), then this parameter is the target setpoint for the differential to be maintained between the signal measured on analog input A1 and the signal measured on analog input A2.

■ **b5-08 PI Primary Delay Time Constant**

Setting Range: 0.00 ~ 10.00 s
 Factory Default: 0.00 s

Acts as a time based filter that lowers the responsiveness of the PI function, but also makes the function more stable when the setpoint varies rapidly or when the feedback is noisy.

■ **b5-09 PI Output Level Selection**

Setting	Description
0	Normal Output (direct acting) <i>(factory default)</i>
1	Reverse Output (reverse acting)

Normally, the output of the PI function causes an increase in motor speed whenever the measured feedback is below the setpoint. This is referred to as direct acting response. However, if b5-09 = “1: Reverse Output,” the output of the PI function causes the motor to slow down when the feedback is below the setpoint. This is referred to as reverse acting response.

■ **b5-10 PI Output Gain Setting**

Setting Range: 0.0 ~ 25.0
 Factory Default: 1.0

Applies a multiplier to the output of the PI function. Using the gain can be helpful when the PI function is used to trim the Speed Command. Increasing b5-10 causes the PI function to have a greater regulating affect on the speed command.

■ **b5-12 PI Feedback Reference Missing Detection Selection**

Setting	Description
0	Disabled
1	Alarm
2	Fault <i>(factory default)</i>

Loss of feedback can cause problems to a PI application. The iQpump drive can be programmed to turn on a digital output whenever a loss of feedback occurs. Feedback Loss Detection is turned on by b5-12. When b5-12 = “1: Alarm,” the iQpump drive acknowledges the loss of feedback without stopping or turning on the fault output (MA-MB). If b5-12 = “2: Fault,” the iQpump drive coasts to a stop and turns on the fault output if the feedback is determined to be lost.

■ **b5-13 PI Feedback Loss Detection Level**

Setting Range: 0 ~ 100 %
 Factory Default: 0 %

■ **b5-14 PI Feedback Loss Detection Time**

Setting Range: 0.0 ~ 25.0 s
 Factory Default: 2.0 s

The iQpump drive interprets feedback loss whenever the feedback signal drops below the value of b5-13 and stays below that level for at least the time set into b5-14. See [Figure 5.3](#) for timing details.

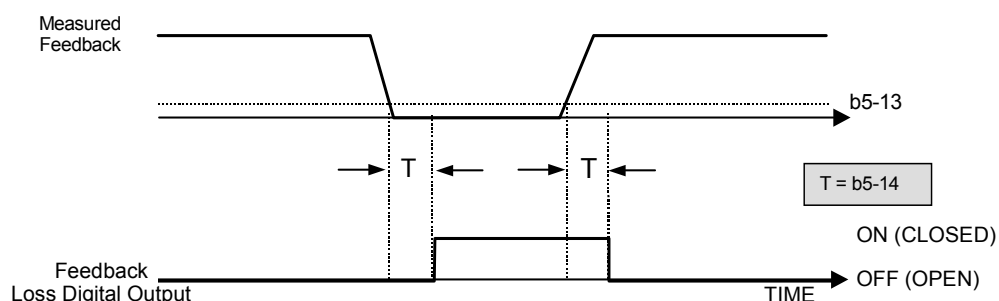

Figure 5.3 Loss of PI Feedback Feature

■ b5-17 PI Accel / Decel Time

Setting Range: 0.0 ~ 25.5 s

Factory Default: 0.0 s

This is a soft start function that is applied to the PI setpoint analog input. Instead of having nearly instantaneous changes in signal levels, there is a programmed ramp applied to level changes. When changing setpoints, the error can be limited by gradually ramping the setpoint through the use of parameter b5-17.

◆ b8 Energy Savings

The energy savings function improves overall system operating efficiency by operating the motor at its highest efficiency. This is accomplished by continuously monitoring the motor load and adjusting the motor terminal voltage so that the motor always operates near its rated slip frequency. A motor is most efficient when operating near rated slip conditions.

■ b8-01 Energy Savings Selection

Setting	Description
0	Disabled (<i>factory default</i>)
1	Enabled

When the Energy Savings function is enabled (b8-01 = "1: Enabled"), the iQpump drive reduces the output voltage to the motor below the voltage value specified by the programmed V/f pattern whenever the motor load is light. Since torque is reduced during this voltage reduction, the voltage has to return to normal levels when the load returns. The energy savings is realized through improved motor efficiency. The reduced output voltage causes increased rotor slipping even with a light load. A motor is most efficient when operating fully loaded (i.e. operating at rated slip).

■ b8-04 Energy Saving Coefficient Value

Setting Range: 0.0 ~ 655.0

Factory Default: Model Dependent

Parameter b8-04 is used in maximizing motor efficiency. The factory setting will be iQpump drive capacity dependant but can be adjusted in small amounts while viewing the kW monitor (U1-08) and running the iQpump drive to minimize the output kW. A larger value typically results in less voltage to the motor and less energy consumption. Too large a value will cause the motor to stall.

■ b8-05 Power Detection Filter Time

Setting Range: 0 ~ 2000 ms

Factory Default: 20 ms

The Energy Saving function will search out the lowest output voltage in order to achieve minimum output power usage. Parameter b8-05 determines how often the output power (kW) is measured and the output voltage is adjusted.

■ b8-06 Search Operation Voltage Limit

Setting Range: 0 ~ 100 %

Factory Default: 0 %

Once Energy Savings is enabled and the optimal energy saving coefficient value has been set, the programmer can have the iQpump drive further search out the proper voltage to achieve the lowest output power by making minute changes to the output voltage and measuring the output power every b8-05 ms. Parameter b8-06 sets limits to the range over which the voltage will be adjusted in order to minimize the power output. Settings too large a value may allow the motor to stall if the load is applied abruptly.

If b8-06 = 0, then the optimum voltage search operation is disabled (but not Energy Savings itself).

◆ C1 Accel / Decel

- C1-01 Acceleration Time 1
- C1-02 Deceleration Time 1
- C1-03 Acceleration Time 2
- C1-04 Deceleration Time 2
- C1-05 Acceleration Time 3
- C1-06 Deceleration Time 3

Setting Range: 0.0 ~ 6000.0 s

Factory Default: C1-01 20.0 s

C1-02, C1-03 and C1-04, 10.0 s

C1-05 and C1-06, 50.0 s

C1-01 (Acceleration Time 1) sets the time to accelerate from zero to maximum speed (E1-04). C1-02 (Deceleration Time 1) sets the time to decelerate from maximum speed to zero. C1-01 and C1-02 are the factory default active accel / decel “pair.” Another accel / decel pair (C1-03 and C1-04) exists that can be activated by a multi-function digital input (H1-0x = 7), or specified by a switch over frequency as programmed in parameter C1-11.

The C1-05 (Acceleration Time 3) and C1-06 (Deceleration Time 3) are used during the multiple pumping operation. Refer to P3-12 (in the Programming Manual) for further description.

◆ d2 Reference (Speed Command) Limits

■ d2-01 Frequency Reference Upper Limit

Setting Range: 0.0 ~ 110.0 %

Factory Default: 100.0 %

■ d2-02 Frequency Reference Lower Limit

Setting Range: 0.0 ~ 110.0 %

Factory Default: 0.0 %

The use of parameters d2-01 and d2-02 places limitations on the speed command that the iQpump drive will accept. The parameters are set in units of percentage of the maximum frequency (E1-04) and provide limits on any remote speed command input. By entering upper or lower frequency limits, the iQpump drive programmer can prevent operation of the iQpump drive above or below levels that may cause resonance, equipment damage or discomfort (see also parameter d3-0x). For example, limits may be needed to prevent low speed operation of: Cooling tower fans with gear boxes, pumps with pressure dependent seals, or AHUs with minimum delivery requirements.

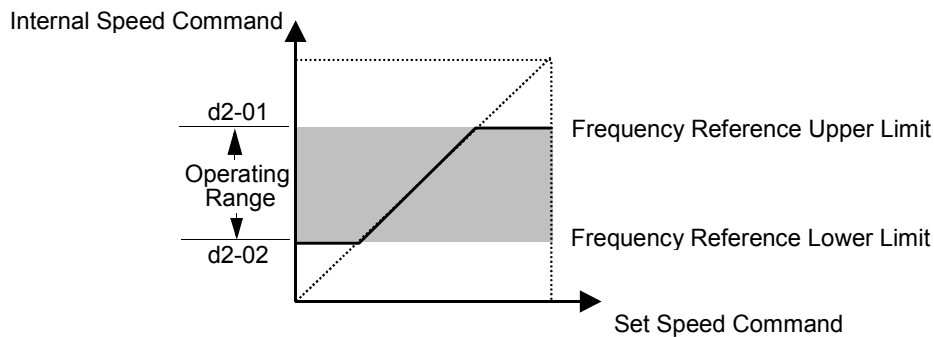

Figure 5.4 Frequency Reference Upper and Lower Limit Effects on the Speed Command

■ **d2-03 Master Speed Reference Lower Limit**

Setting Range: 0.0 ~ 110.0 %
 Factory Default: 0.0 %

Unlike Frequency Reference Lower Limit (d2-02) which will affect the speed command no matter where it is sourced from (i.e. analog input, preset speed, jog speed, etc.), the Master Speed Reference Lower Limit (d2-03) sets a low speed threshold that will only affect the analog input that is the active master speed frequency (as determined by parameter H3-13 and H3-09). This parameter allows a minimum speed to be programmed for the master reference while allowing a lower speed to be set as a jog reference. If the speed commanded by the active master speed frequency is below the setting of d2-03, then the iQpump drive will operate at the speed specified by d2-03.

◆ **d3 Jump Frequencies**

- **d3-01 Jump Frequency 1**
- **d3-02 Jump Frequency 2**
- **d3-03 Jump Frequency 3**

Setting Range: 0.0 ~ 200.0 Hz
 Factory Default: 0.0 Hz

■ **d3-04 Jump Frequency Width**

Setting Range: 0.0 ~ 20.0 Hz
 Factory Default: 1.0 Hz

In order to avoid continuous operation at a speed that causes resonance in driven machinery, the iQpump drive can be programmed with jump frequencies that will not allow continued operation within specific frequency ranges. If a speed is commanded that falls within a dead band, or Jump Frequency, the iQpump drive will clamp the frequency reference just below the dead band and only accept higher speed commands when the commanded speed rises above the upper end of the dead band, for increasing references. Similarly, the iQpump drive will clamp the frequency reference just above the dead band and only accept lower speed commands when the command speed falls below the lower end of the dead band, for decreasing references.

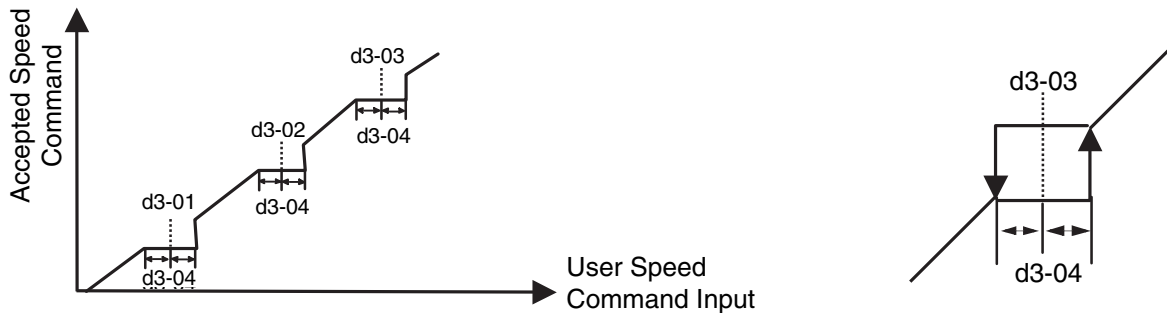

Figure 5.5 Jump Frequency Characteristics

Setting the center point of the dead band with the d3-01 through d3-03 parameters and setting the width of the dead band with parameter d3-04 determines the dead band characteristics. The programmer can set up to three Jump Frequencies. If multiple Jump Frequencies are programmed the following rule applies:

$$d3-01 \leq d3-02 \leq d3-03$$

◆ E1 V/f Pattern

■ E1-01 Input Voltage Setting

Setting Range: 155.0 V ~ 255.0 V (208 V / 240 V Models)
310.0 V ~ 510.0 V (480 V Models)

Factory Defaults: 208.0 V (208 V Models)
240.0 V (240 V Models)
480.0 V (480 V Models)

Set the Input Voltage parameter (E1-01) to the nominal voltage of the connected AC power supply. This parameter adjusts the levels of some protective features of the iQpump drive (i.e., Overvoltage, Stall Prevention, etc.). E1-01 also serves as the Maximum / Base Voltage used by the Preset V/Hz curves (E1-03 = 0 to D).

■ E1-03 V/f Pattern Selection

Table 5.2

Setting	Description
0	50 Hz
1	60 Hz Saturation
2	50 Hz Saturation
3	72 Hz
4	50 Hz VT1
5	50 Hz VT2
6	60 Hz VT1
7	60 Hz VT2
8	50 Hz HST1
9	50 Hz HST2
A	60 Hz HST1
B	60 Hz HST2
C	90 Hz
D	120 Hz
E	180 Hz (invalid - OPE2 fault will occur)
F	Custom V/f (factory default, with parameter values per setting 1)
FF	Custom w/o limit

The iQpump drive operates utilizing a set V/f pattern to determine the appropriate output voltage level for each commanded speed. There are 14 different preset V/f patterns to select from with varying voltage profiles, saturation levels (frequency at which maximum voltage is reached), and maximum frequencies.

There are also settings for Custom V/f patterns that will allow the programmer to manually set (“Customize”) the V/f pattern using parameters E1-04 through E1-13.

Using parameter E1-03, the programmer can select one of the preset V/f patterns or chose between a custom V/f pattern with an upper voltage limit (E1-03 = “F: Custom V/F”) and a custom V/f pattern without a voltage limit (E1-03 = “FF: Custom w/o limit”).

Table 5.3 Preset V/f Patterns

Specifications		E1-03	V/f Pattern *1		Specifications	E1-03	V/f Pattern *1	
General-purpose	50 Hz	0		High Starting Torque *2	50 Hz	8		
	60 Hz Saturation	1			60 Hz	9		
	50 Hz Saturation	2			60 Hz	A		B
	72 Hz	3			90 Hz	C		
Variable Torque	50 Hz	Variable Torque 1	4	High Speed Operation	120 Hz	D		
		Variable Torque 2	5					
	60 Hz	Variable Torque 1	6					
		Variable Torque 2	7					

If one of the custom V/f patterns is selected, then parameters E1-04 through E1-13 will determine the V/f pattern.

Table 5.3 is for 240V class units only. For 480V class units multiply the voltage value by 2.

Important: When a factory Initialization is performed, the setting of E1-03 is unaffected but the settings of E1-04 through E1-13 are returned to their factory default settings.

■ **E1-04 Maximum Output Frequency**

Setting Range: 0.0 ~ 120.0 Hz
 Factory Default: 60.0 Hz

■ **E1-05 Maximum Output Voltage**

Setting Ranges: 0.0 ~ 255.0 V (240 V Models)
 0.0 ~ 510.0 V (480 V Models)

Factory Defaults: 230.0 V (240 V Models)
 460.0 V (480 V Models)

■ E1-06 Base Frequency

Setting Range: 0.0 ~ 200.0 Hz

Factory Default: 60.0 Hz

■ E1-07 Mid Output Frequency A

Setting Range: 0.0 ~ 200.0 Hz

Factory Default: 3.0 Hz

■ E1-08 Mid Output Voltage ASetting Ranges: 0.0 ~ 255.0 V (240 V Models)
0.0 ~ 510.0 V (480 V Models)Factory Defaults: 17.2 V (240 V Models)
34.5 V (480 V Models)**■ E1-09 Minimum Output Frequency**

Setting Range: 0.0 ~ 200.0 Hz

Factory Default: 1.5 Hz

■ E1-10 Mid Output VoltageSetting Ranges: 0.0 ~ 255.0 V (240 V Models)
0.0 ~ 510.0 V (480 V Models)Factory Defaults: 10.3 V (240 V Models)
20.7 V (480 V Models)**■ E1-11 Mid Output Frequency B**

Setting Range :0.0 ~ 120.0 Hz

Factory Default: 0.0 Hz

■ E1-12 Mid Output Voltage B**E1-13 Base Voltage**Setting Ranges: 0.0 ~ 255.0 V (240 V Models)
0.0 ~ 510.0 V (480 V Models)

Factory Defaults:0.0 V (All Models)

To set up a custom V/f pattern, program the points shown in the diagram below using parameters E1-04 through E1-13. Be sure that the following condition is true: $E1-09 \leq E1-07 \leq E1-06 \leq E1-11 \leq E1-04$.

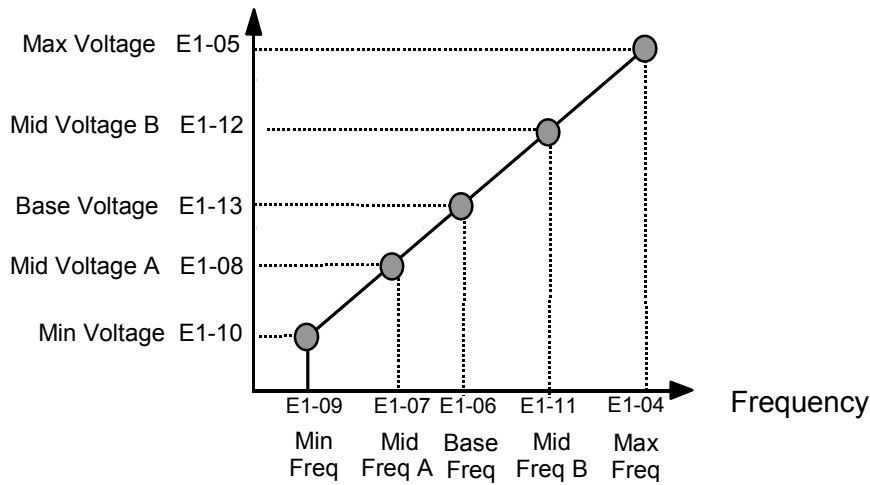

Figure 5.6 Custom V/f Pattern Programming Curve

Increasing the voltage in the V/f pattern increases the available motor torque. However, when setting a custom V/f pattern, increase the voltage gradually while monitoring the motor current, to prevent:

- iQpump drive faults as a result of motor over-excitation
- Motor overheating or excessive vibration

◆ E2 Motor Setup

■ E2-01 Motor Rated Current

Setting Range: 10 % ~ 200 %
 Factory Default: Model Dependent

The Motor Rated Current parameter (E2-01) is necessary information for the iQpump drive motor protection function. The motor overload protection parameter L1-01 is enabled by default. In addition, motor rated current is used by the torque compensation function to insure optimum torque production. Set E2-01 to the full load amps (FLA) value stamped on the motor’s nameplate. During Auto-Tuning, it is required for the operator to enter the motor rated current in parameter T1-04 on the Auto-Tuning menu. If the Auto-Tuning operation completes successfully, the value entered into T1-04 will be also written into E2-01.

For applications employing a iQpump drive that is oversized for the motor, E2-01 may be set as low as 10 % of the iQpump drive output current rating. The AMP value in E2-01, however, must always be greater than the “No Load Current” value in parameter E2-03 or an OPE02 error will be displayed.

■ E2-03 No Load Current

Setting Range: Model Dependent
 Factory Default: Model Dependent

Set E2-03 to the motor no-load current at rated voltage and rated frequency. Consult the motor manufacturer for the proper value if the No Load Current is not stated on the motor nameplate.

■ E2-04 Number of Motor Poles

Setting Range: 2 ~ 48
 Factory Default: 2

This parameter sets the number of motor poles used for no-flow detection function and for the calculation of rpm-related parameters.

◆ H3 Analog Inputs

■ H3-02 Terminal A1 Gain Setting

Setting Range: 0.0 ~ 1000.0 %
Factory Default: 100.0 %

■ H3-03 Terminal A1 Bias Setting

Setting Range: -100.0 % ~ +100.0 %
Factory Default: 0.0 %

In order to have the iQpump drive properly interpret an analog input, it may be necessary to apply a gain and / or a bias to the signal. The analog inputs have a resolution of 10 bits (1024 steps). Using the factory default settings for the analog input's gain and bias, the 0 ~ 10 Vdc or 4-20 mA signal at the analog input will yield a 0 ~ 100 % speed command span.

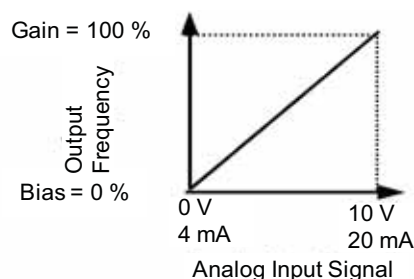

Figure 5.34 Output Frequency as Commanded Via Analog Input

If a different span of analog input signal is desirable, it will be necessary to adjust the gain, the bias, or both to allow the analog input level to generate the desired frequency command. Adjustment of the gain setting will change the speed command that is equivalent to the maximum analog input (10 Vdc or 20 mA). If, for instance, the gain is increased to 200 %, then 10 Vdc or 20 mA will be equivalent to a 200 % speed command and 5 Vac or 12 mA will be equivalent to a 100 % Speed Command. Since the iQpump drive output is limited by the maximum frequency parameter (E1-04), 0 - 5 Vdc or 4 ~ 12 mA will now be equivalent to 0 - 100 % speed command span.

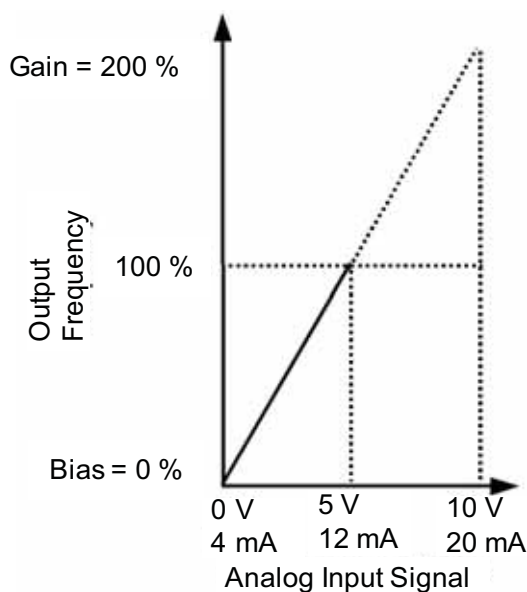

Figure 5.35 Output Frequency as Commanded via Analog Input with Increased Gain Setting

Adjustment of the bias setting will likewise adjust the speed command that is equivalent to the minimum analog input level (0 Vdc or 4 mA). If, for instance, the bias is set to -25 %, then 0 Vdc or 4 mA will be equivalent to a -25 % speed command. Since the minimum speed command is 0 % an analog input of 2.5 to 10 Vdc or 8 to 20 mA will now be equivalent to 0 ~ 100 % speed command span.

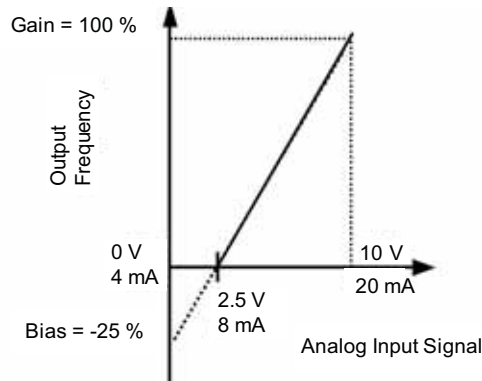

Figure 5.36 Output Frequency with Reduced Bias Setting

As a further example, for an inverse-acting speed command, set the bias = 100 % and the gain = 0 %. The minimum analog input level (0 Vdc or 4 mA) will produce a 100 % speed command and the maximum analog input level (10 Vdc or 20 mA) will produce a 0 % speed command.

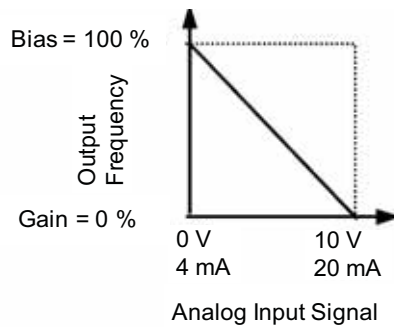

Figure 5.37 Output Frequency with Inverted Gain and Bias Settings

■ H3-08 Terminal A2 Signal Level

Setting	Description
0	0 - 10 Vdc
2	4 ~ 20 mA (factory default)
3	0 - 20 mA

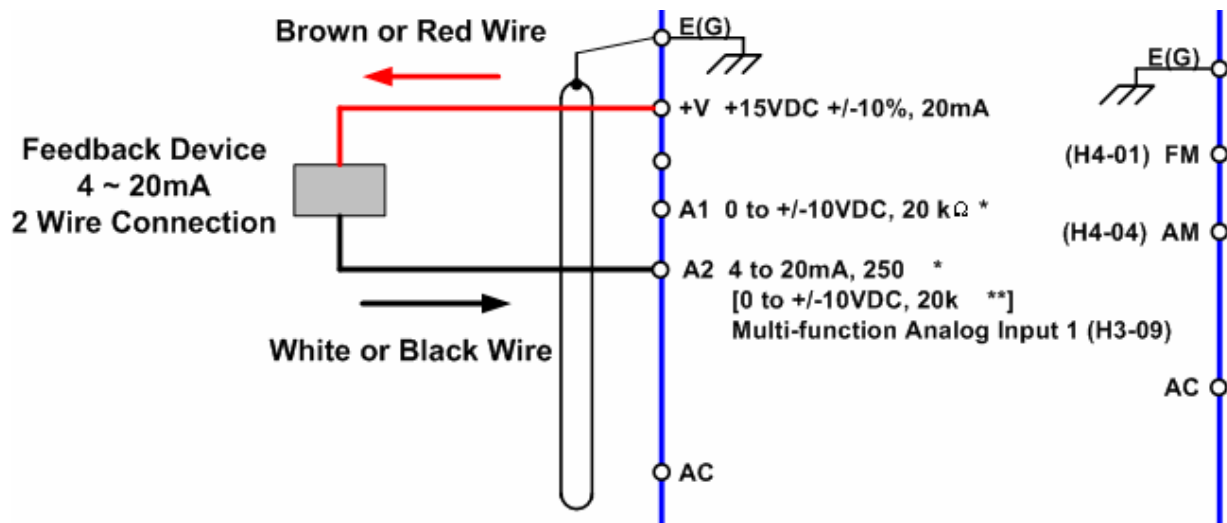

Figure 5.38 Connection of a 2-Wire 4~20 mA Feedback Device (H3-08 = 2)

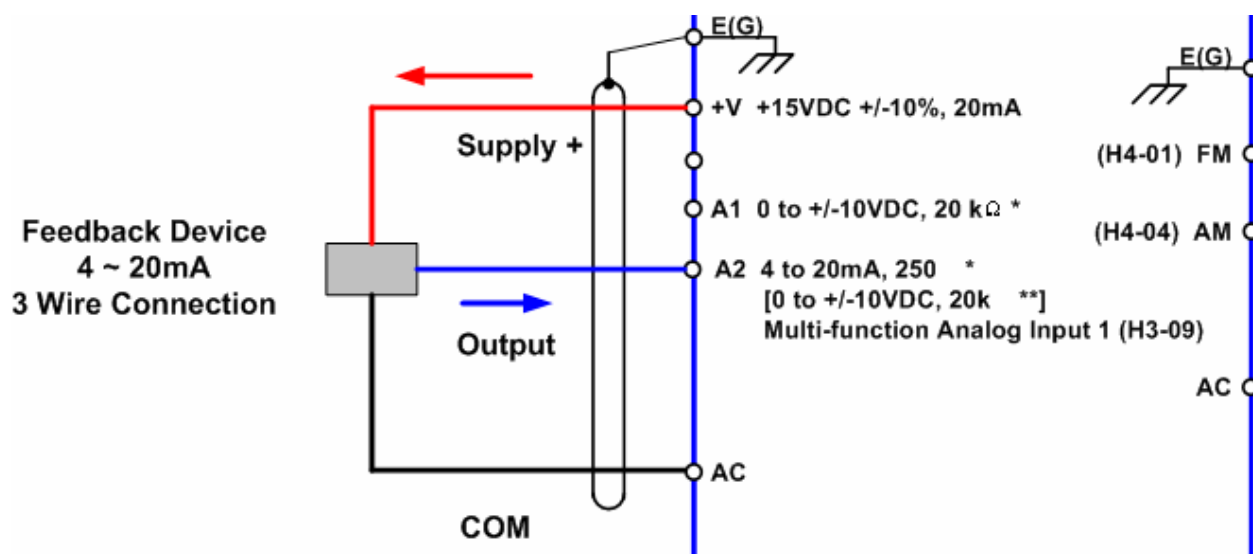

Figure 5.39 Connection of a 3-Wire 4~20 mA Feedback Device (H3-08 = 2)

The H3-08 parameter (Terminal A2 Signal Level) allows the programmer to specify the signal that will be applied to the A2 analog input. The A2 analog input can accept either a 0–10 Vdc or 4 ~ 20 mA signal as a reference. The iQpump drive also has a DIP switch (S1) on the removable terminal board that must be set for the proper reference signal into the A2 analog input. The S1-2 DIP switch setting determines the internal resistance of the A2 input while parameter H3-08 determines how the iQpump drive interprets the measured signal.

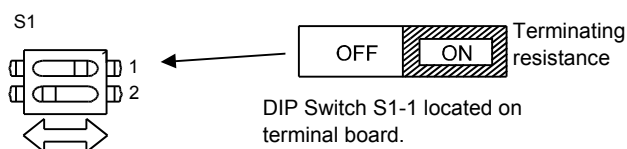
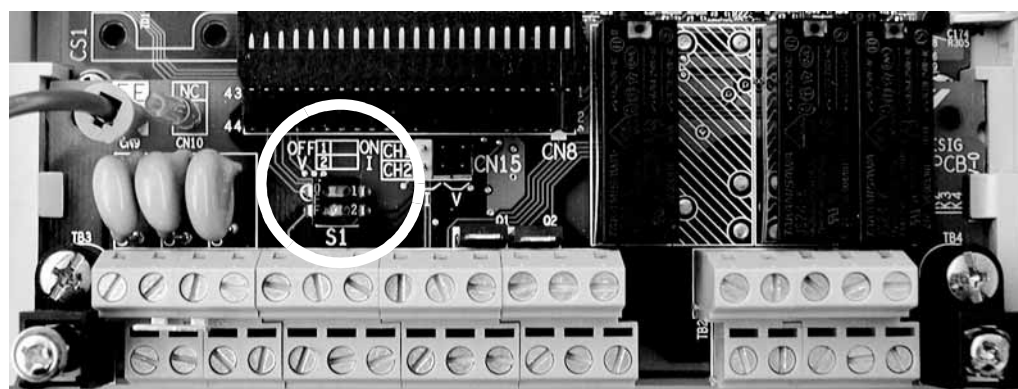

Figure 5.40 DIP Switch S1

Table 5.4 DIP Switch S1

Name	Function	Setting
S1-1	RS-485 and RS-422 terminating resistance	OFF: No terminating resistance ON: Terminating resistance of 110 Ω
S1-2	Input method for analog input A2	OFF: 0 ~ 10 V (internal resistance: 20 kΩ) ON: 4 ~ 20 mA (internal resistance: 250 Ω) (Default)

■ H3-09 Terminal A2 Function Selection

Setting	Description
0	Frequency Bias
2	Aux Reference
B	PI Feedback (<i>factory default</i>)
D	Frequency Bias 2
E	Motor Temperature
16	PI Differential
1F	Not Used

The A2 analog input can be programmed to perform many different functions. The setting of parameter H3-09 determines which of the following functions the A2 analog input will perform.

Function: Frequency Bias

Setting: 0

By setting H3-09 = “0: Frequency Bias,” the A2 analog input will serve as a bias signal to the A1 Speed Command. The effect of using A2 for a frequency bias is that the level of the A2 analog input will be summed with the level of the Speed Command analog input (A1). For example, if H3-02 = 100 %, H3-03 = 0 %, and the A2 analog input level is 1 Vdc, the Speed Command profile will look like the figure below. If A1 = 0 Vdc the Speed Command would be 10 % of the programmed maximum frequency because A1 (0 Vdc) + A2 (1 Vdc) = 1 Vdc.

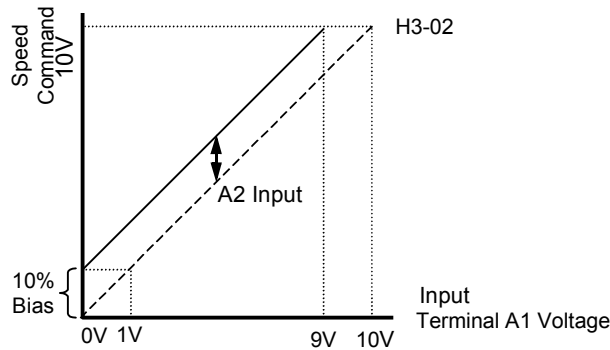

Figure 5.41 Effect of Frequency Bias Function on Speed Command

It should be noted that the bias applied by the A2 analog input functions differently than the level set by the H3-03. If both biases are used simultaneously they will sum together.

The level of the A1 analog input, as a percentage of the maximum input (either 10 Vdc or 20 mA), can be viewed by the U1-15 monitor. The level of the A2 analog input, as a percentage of the maximum input, can be viewed by the U1-16 monitor.

The bias applied by setting H3-09 = “0: Frequency Bias,” can be used in conjunction with the parameter bias H3-03. In that case the H3-03 bias is applied first which changes the slope of the Speed Command vs. Terminal A1 Voltage graph. Then the level of the A2 analog input is summed with the A1 analog input level, which in effect shifts the Speed Command vs. Terminal A1 Voltage graph upwards or downwards but does not change the slope of the line.

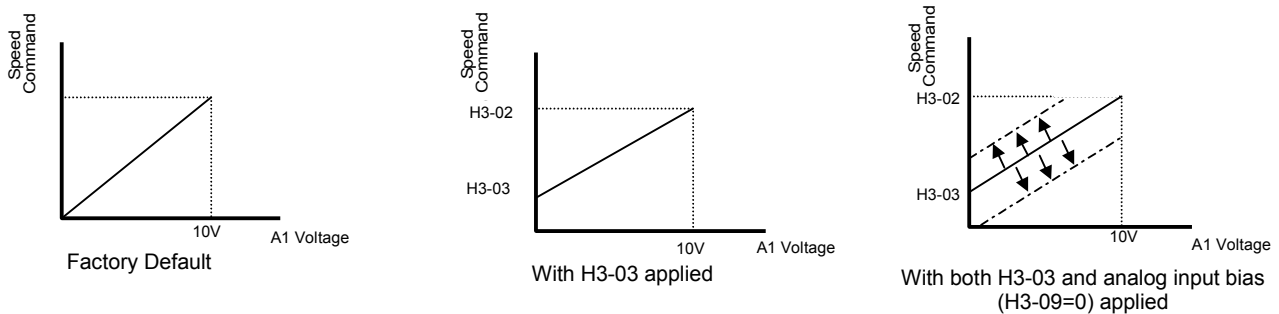

Figure 5.42 Frequency Bias Applied to Analog Speed Command

Function: Aux Reference
Setting: 2

In order for the A2 analog input to be used as the master Speed Command, parameter H3-09 must be set for Aux Reference (H3-09 = “2: Aux Reference”). Once A2 is configured as an auxiliary reference, it can be selected as the master Speed Command by setting H3-13 = “1: Main Fref TA2.” If H3-09 = 2, terminal A2 analog input will become the speed command when a digital input programmed for Multi-Step Ref 1 (H1-0x = 3) is selected by a contact closure.

Function: PI Feedback
Setting: B

Configuring the A2 analog input as PI Feedback (H3-09 = “B: PI Feedback”) is a requirement of setting the iQpump drive up for PI operation. The A2 analog input is the only source for feedback for PI operation though the setpoint can come from a number of different sources (refer to the section covering the PI parameters for more information regarding specifying the setpoint source. PI parameters are listed in section b5).

Parameters H3-10 (Terminal A2 Gain) and H3-11 (Terminal A2 Bias) can be used to configure the A2 analog input to match the signal from the Feedback Transmitter.

The U1-24 monitor (PI Feedback) can be used to check the PI Feedback level with the digital operator.

Function: Frequency Bias 2
Setting: D

By setting H3-09 = “D: Frequency Bias 2,” the A2 analog input will serve as a bias signal to the A1 Speed Command. This setting functions the same as a setting of H3-09 = 0: Frequency Bias.

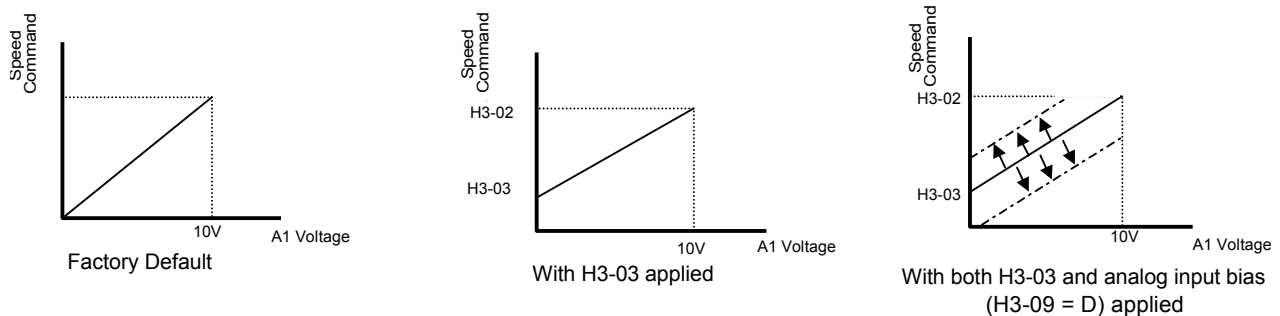

Figure 5.43 Frequency Bias 2 Applied to Analog Speed Command

Function: PI Differential
Setting: 16

Normal PI operation will adjust the iQpump drive output in order to match the measured feedback value to a desired setpoint. When PI is operated in the differential mode, however, the iQpump drive output is adjusted in order to maintain a desired differential between two feedback signals.

When the A2 analog input is configured as a PI Differential (H3-09 = “16: PI Differential”), the A1 analog input becomes the other PI Differential input. The desired differential is set by parameter b5-07 (PI Differential Setpoint) and can be set so that A2 is held less than A1 (b5-07 < 0) or A2 is held greater than A1 (b5-07 > 0).

When PI Differential operation is chosen, the A1 feedback level can be monitored by U1-24 (PI Feedback) and the A2 feedback level can be monitored by U1-53 (PI Feedback2).

Function: Not Used
Setting: 1F

When H3-09 = “1F: Not Used,” any signal applied to the A2 analog input will be ignored by the iQpump drive.

■ **H3-10 Terminal A2 Gain Setting**

Setting Range: 0.0 ~ 1000.0 %
 Factory Default: 100.0 %

■ **H3-11 Terminal A2 Bias Setting**

Setting Range: -100.0 % ~ +100.0 %
 Factory Default: 0.0 %

Parameters H3-10 and H3-11 perform the same function for the A2 analog input that parameters H3-02 and H3-03 perform for the A1 analog input. Please refer to the parameter description for H3-02 and H3-03 for information about H3-10 and H3-11.

These parameters could be used for final calibration of a factory or field installed pressure to electric transducer input connected to terminal A2 and AC. This field calibration may be needed if there is a job site variation from the typical 3 to 15 psiG pneumatic signal input range.

■ **H3-12 Analog Input Filter Time Constant**

Setting Range: 0.00 ~ 2.00 s
 Factory Default: 0.30 s

An analog input filter can be used to prevent erratic iQpump drive control when a “noisy” analog reference is used. Parameter H3-12 sets the time constant for a first order filter that will be applied to both the A1 and A2 analog inputs. The iQpump drive operation becomes more stable the longer the time programmed, but it becomes less responsive to rapidly changing analog signals.

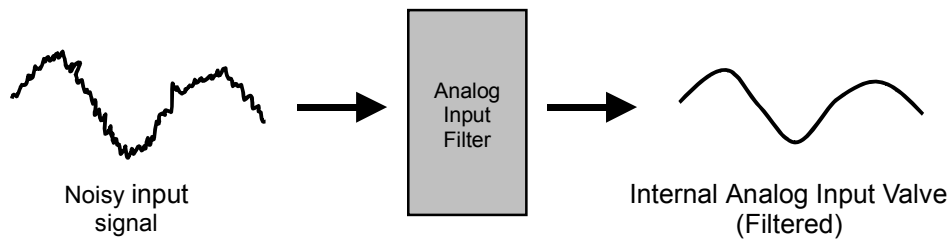

Figure 5.44 Analog Input Filter Time Constant Effect on “Noisy” Signal

■ **H3-13 Master Frequency Reference Terminal Selection**

Setting	Description
0	Main Fref = A1 (<i>factory default</i>)
1	Main Fref = A2

Parameter H3-13 allows the programmer to select which analog input will serve as the Speed Command input when “Terminals” are selected as the Auto Mode Speed source (b1-01 = “1: Terminals”), or Terminal is selected as the reference source for the Hand mode (b1-12 = “1: Terminals”). For the A2 analog input to be an effective selection for the H3-13 parameter, parameter H3-09 must be configured as Aux Reference (H3-09 = “2: Aux Reference”).

If H3-09 ≠ 2, then the A1 analog input will be used regardless of the setting of parameter b1-12.

◆ **L2 Momentary Power Loss Ride-Thru Function**

When momentary power loss recovery is enabled (L2-01 ≠ 0), a speed search is executed to catch the potentially spinning motor shaft. This speed search will occur regardless of the setting of b3-01 “Speed Search Selection.”

■ **L2-01 Momentary Power Loss Detection Selection**

Setting	Description
0	Disabled
1	PwrL Ride Thru t
2	CPU Power Active (<i>factory default</i>)

■ L2-02 Momentary Power Loss Ride-Thru Time

Setting Range: 0.0 ~ 25.5 s

Factory Default: Model Dependent

The iQpump drive allows different responses to momentary power losses. The setting of L2-01 determines whether the iQpump drive attempts to restart after a short loss of incoming AC power and for what length of time this capability remains active.

If L2-01 = “0: Disabled,” the iQpump drive detects a UV1 fault 15 ms after power loss and automatic restarting is disabled. The iQpump drive cannot restart until the external run command is removed and the UV1 fault is reset.

If L2-01 = “1: PwrL Ride Thru t,” the iQpump drive restarts without the UV1 fault if power is returned within the time specified in L2-02, the Momentary Power Loss Ride-thru Time. During the power loss but before the fault trip, the digital operator will display a UV alarm. If L2-02 is set for a time longer than the control power supply can be sustained, a UV1 fault will not occur and the iQpump drive restarts upon the return of AC power. The time that the control power supply can be maintained varies with iQpump drive size. The larger the iQpump drive, the greater the potential ride-thru time.

If L2-01 = “2: CPU Power Active,” the iQpump drive ignores L2-02 and attempts a restart as long as the control power supply is still able to maintain a minimal voltage level. In effect, setting L2-01 = “2: CPU Power Active” (factory default) is programming the iQpump drive for maximum Power Loss Ride-thru. An equivalent setting is L2-01 = “1: PwrL Ride Thru t,” with L2-02 set to a time longer than the control power supply can be maintained after power is lost.

Note: The run command must be held during power loss for any power loss ride-thru capability to be possible. It is for this reason that 3-wire control is not recommended for use with the Momentary Power Loss function.

◆ L5 Fault Restart

■ L5-01 Number of Auto Restart Attempts

Setting Range: 0 ~ 10

Factory Default: 5

■ L5-02 Auto Restart Operation Selection

Setting	Description
0	No Flt Relay (<i>factory default</i>)
1	Flt Relay Active

■ L5-03 Maximum Restart Time After Fault

Setting Range: 10.0 ~ 3600.0 s

Factory Default: 20.0 s

All major faults will cause the iQpump drive to stop. For some faults it is possible to configure the iQpump drive to attempt a restart automatically. After the fault occurs, the iQpump drive baseblocks for the Maximum Restart Time After Fault programmed in L5-03. After the baseblock is removed the iQpump drive checks if a fault condition still exists. If no fault condition exists the iQpump drive will attempt to restart the motor. If the restart is successful, the iQpump drive performs a Speed Search (Regardless of the status of b3-01 “Speed Search Selection”) from the set speed command and the Auto Restart Attempts count is increased by one. Even if the restart fails the restart count is increased by one as long as the iQpump drive attempted to rotate the motor. The restart count will not accumulate if the restart is not attempted due to a continuing fault condition, (i.e. an OV fault). The iQpump drive waits the Maximum Restart Time After Fault (L5-03) before attempting another restart. This parameter is not applicable to Loss of Prime Fault.

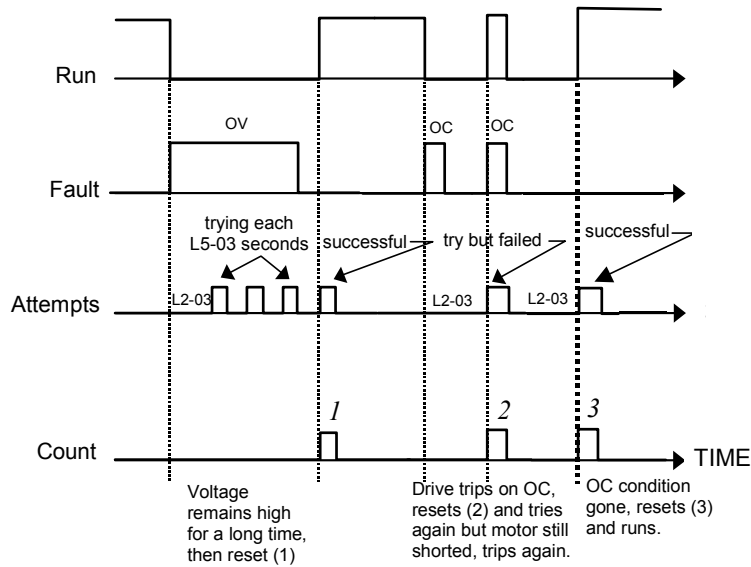

Figure 5.45 Automatic Restart Timing Diagram

The auto restart count is reset back to 0 if any of the following occur:

- No further faults for ten minutes after the last retry.
- The iQpump drives power is turned off (the iQpump drive must be without power long enough to let control power dissipate).
- The SHIFT / RESET key is pushed after the last reset attempt.

The setting of parameter L5-02 determines whether the fault output (MA-MB) will be closed during an auto restart attempt. The setting of L5-02 can be important when interfacing the iQpump drive with other equipment.

The following faults will allow the Auto Restart function to initiate:

- OC (Overcurrent)
- LF (Output Open Phase)
- PF (Input Phase Loss)
- PUF (DC Bus Fuse)
- OL1 (Motor Overload)
- OL3 (Overtorque)
- OL2 (Drive Overload)
- OV (DC Bus Overvoltage)
- GF (Ground Fault)
- UV1 (DC Bus Undervoltage)
- OH1 (Overheat)

In order for auto restart after a UV1 fault, Momentary Power Loss Ride-thru must be enabled (L2-01 = “1: PwrL Ride Thru t,” or “2: CPU Power Active”). Setting H2-01 or H2-02 equal to “1E” configures a digital output as “Restart Enabled” to signal if an impending auto restart is possible.

◆ L6 Torque Detection

■ L6-01 Torque Detection Selection 1

Setting	Description
0	Disabled (<i>factory default</i>)
1	OL@SpdAgree - Alm
2	OL At Run - Alm
3	OL@SpdAgree - Flt
4	OL At Run - Flt
5	UL@SpdAgree - Alm
6	UL at Run - Alm
7	UL@SpdAgree - Flt
8	UL At Run - Flt

■ L6-02 Torque Detection Level 1

Setting Range: 0 ~ 300 % of iQpump drive rated output current

Factory Default: 15 % of iQpump drive rated output current

■ L6-03 Torque Detection Time 1

Setting Range: 0.0 ~ 10.0 s

Factory Default: 10.0 s

The iQpump drive can be programmed to indicate when either an overtorque or an undertorque conditions exist. A digital output must be programmed for “Torque Detection,” (H2-01/H2-02 = “B: Trq Det 1 N.O.” or “17: Trq Det 1 N.C.”). A warning of an overtorque condition can indicate a jam and an undertorque condition can indicate a broken belt, no water in a pump, or other loss of load.

To configure Torque Detection requires the following decisions:

1. Do you wish to check for an overtorque condition or an undertorque condition?
2. Do you wish to check for the torque condition whenever the iQpump drive is running or only at speed agree? Nuisance detection during acceleration, when variable torques are normally required, can be avoided.
3. Do you want the iQpump drive to fault if the torque condition is detected or only alarm and continue operation?

The following table can help choose the proper setting for Torque Detection Selection 1 to get the wanted results.

Table 5.5 L6-01 Setting Choices

L6-01 Setting	Overtorque	Undertorque	Fault	Alarm	Always Detected	Only Detected @ Spd Agree
0	Torque Detection Disabled					
1	X			X		X
2	X			X	X	
3	X		X			X
4	X		X		X	
5*		X		X		X
6		X		X	X	
7		X				X
8		X			X	

*Suggested settings for Loss of Load indication

After selecting the proper detection scheme the Torque Detection Level (L6-02) must be specified. If the current level read by the output current transformers rises above (overtorque) or drops below (undertorque) this level, and remains there for at least the Torque Detection Time (L6-03), then the Torque Detection Function will change the state of any digital output configured for Torque Detection (H2-01 / H2-02 = “B: Trq Det 1 N.O.” or “17: Trq Det 1 N.C.”).

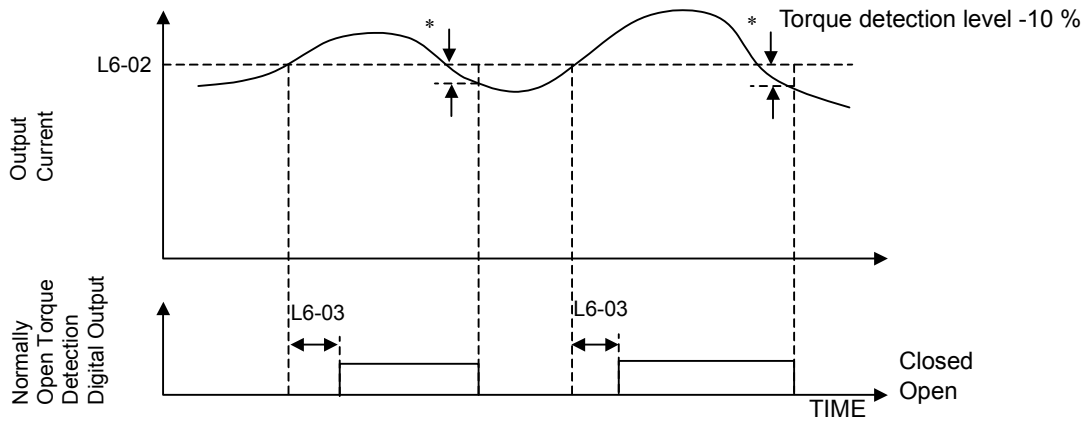

* When the output current drops below the Torque Detection Level by approximately 10% of the Drive's rated output current the digital output is reset.

Figure 5.46 Over Torque Detection

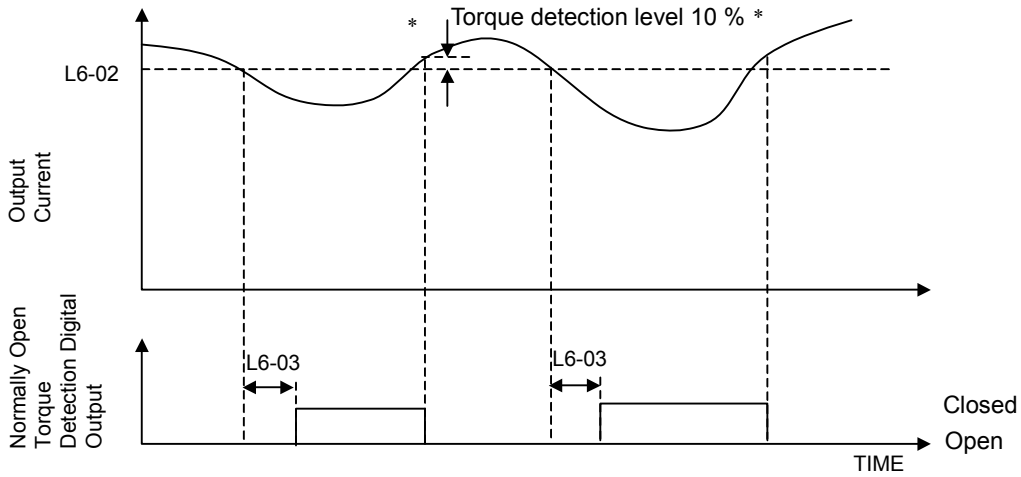

* When the output current rises above the Torque Detection Level by approximately 10% of the Drive's rated output current the digital output is reset.

Figure 5.47 Under Torque Detection

◆ L8 Hardware Protection

■ L8-01 Internal Dynamic Braking Resistor Protection Selection

Setting	Description
0	Not Provided (<i>factory default</i>)
1	Provided

This parameter is not applicable for iQpump drive operation.

■ L8-02 Overheat Pre-Alarm Level

Setting Range: 50 ~ 130 °C
 Factory Default: 95 °C

■ L8-03 Overheat Pre-Alarm Operation Selection

Setting	Description
0	Ramp to Stop (Decel Time C1-02)
1	Coast to Stop
2	Fast-Stop (Decel Time C1-09)
3	Alarm Only
4	OH Alarm and Reduce (<i>factory default</i>)

The iQpump drive is capable of warning the operator of an impending heatsink over-temperature fault via an OH pre-alarm. The level at which the pre-alarm will activate is determined by the setting of parameter L8-02. Measurement of the heatsink temperature is done with several strategically mounted thermistors. If any of the heatsink thermistors measure a temperature in excess of the setting of L8-02, the iQpump drive will fault (OH2) and either: ramp to stop using the C1-02 deceleration rate (L8-03 = “0: Ramp to Stop”), coast to stop (L8-03 = “1: Coast to Stop”), ramp to stop using the C1-09 fast stop deceleration rate (L8-03 = “2: Fast-Stop”), alarm (OH) and continue running (L8-03 = “3: Alarm Only”), alarm (OH) and continue running but at a reduced speed (L8-03 = “4: Alarm & Reduce”). If L8-03 = 4: Alarm and Reduce, the iQpump drive will continue to run but will reduce the speed to the level determined by parameter L8-19. Refer to the description for parameter L8-19.

If a digital output is configured for OH Prealarm (H2-01 = “20: OH PreAlarm”), it will close whenever the heatsink temperature is greater than the L8-02 level no matter what the setting is of L8-03.

■ L8-05 Input Phase Loss Protection <0033>

Setting	Description
0	Disabled
1	Enabled (<i>factory default</i>)

The input phase loss detection circuit monitors the DC bus current ripple and activates when one of the input phases is lost. The detection circuit calculates the maximum and minimum values of the DC bus voltage in one second intervals, and compares the difference (ΔV) between these values with an internal detection level. If ΔV reaches or exceeds the detection level, after 0.5 second, the input phase loss is detected; a PF fault occurs and the motor coasts to a stop.

Input phase loss detection is disabled in the following cases:

- A Stop command is input
- Magnetic Contactor (MC) shuts OFF
- CPU A/D converter fault (CPF5)
- During deceleration
- Output current $\leq 30\%$ of Inverter rated current

■ L8-06 Input Phase Loss Detection Level

Setting Range: 0.0 ~ 25.0 % of iQpump drives OV Trip point

Factory Default: Drive Model Dependent

The iQpump drive checks for a lost input phase by monitoring the DC Bus voltage ripple. After an initial delay of approximately 12 seconds, the iQpump drive will sample the DC BUS voltage every 1.28 seconds to determine the minimum and maximum voltage readings. The difference between the minimum and maximum voltage is averaged over ten consecutive scans. If this “averaged” value is greater than the trip level as determined by L8-06 (L8-06 x 400 for 200 volt class iQpump drives; L8-06 x 800 for 400 volt class iQpump drives) the iQpump drive shuts down and displays “PF,” an input phase loss fault.

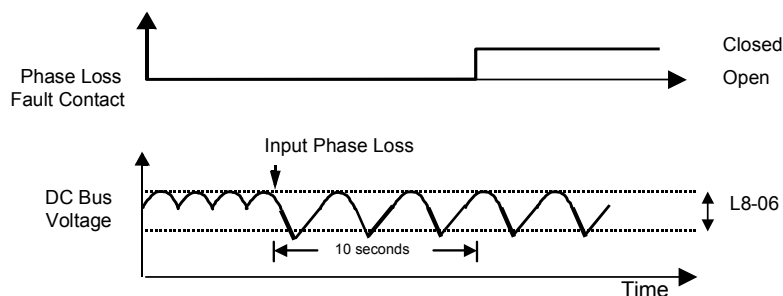

Figure 5.48 Input Phase Loss Detection Diagram

■ **L8-07 Output Phase Loss Protection** <0033>

Setting	Description
0	Disabled
1	Enabled (<i>factory default</i>)

The output phase loss detection circuit monitors the DCCT and activates when one or more of the output phases are lost. The detection circuit calculates the RMS current value (I_{RMS}) for each of the phases and compares it with an internal output detection level. If I_{RMS} decreases to or below the detection level for 10 seconds, an output phase loss (LF) fault occurs and the motor coasts to a stop.

■ **L8-09 Output Ground Fault Detection Selection**

Setting	Description
0	Disabled
1	Enabled (<i>factory default</i>)

The iQpump drive has a ground fault detection circuit that activates when the current to ground exceeds 50 % of the iQpump drive’s rated output current. The current to ground is determined by comparing the measured current on each of the output phases. If the current to ground is determined to be above 50 % of the drive’s rated output current the digital operator will display a GF and the iQpump drive will coast to stop.

■ **L8-10 Heatsink Cooling Fan Operation Selection**

Setting	Description
0	Fan On-Run Mode (<i>factory default</i>)
1	Fan Always On

Refer to L8-11 description.

■ **L8-11 Heatsink Cooling Fan Operation Delay Time** <0033>

Setting Range: 0 ~ 300 s

Factory Default : 300 s

Parameters L8-10 and L8-11 allow the iQpump drive programmer to customize the heatsink cooling fan operation. Parameter L8-10 determines whether the cooling fans are always ON whenever the iQpump drive is powered (L8-10 = “1: Fan Always On”) or if the cooling fans are only ON when the iQpump drive is in a Run condition (L8-10 = “0: Fan On-Run Mode”).

Parameter L8-11 is a delayed OFF for the cooling fan if L8-10 = “0: Fan On-Run Mode”. When the cooling fans are set to turn OFF is when either the Run command is removed or the drive is in baseblock. The iQpump parameter L8-11 will cause the fans to continue cooling the iQpump drive for the amount of time programmed into L8-11 after the Run command is actually removed or baseblocked enabled. The iQpump drive can be programmed to allow the cooling fan to run for up to 5 minutes (factory default) after the run command is removed or baseblock enabled.

Both parameters are intended to extend fan life while still providing sufficient cooling for proper iQpump drive operation.



Figure 5.49 Heatsink Cooling Fan Operation Timing Diagram

■ L8-19 Overheat Frequency Reference Reduction Level

Setting Range: 0.0 ~ 100.0 % of maximum frequency

Factory Default: 20.0 % of maximum frequency

When the heatsink temperature reaches the OH Pre-alarm level (L8-02) and the Overheat Pre-Alarm Operation Selection parameter is set for Alarm and Reduce (L8-03 = “4: OH Alarm and Reduce”), the L8-19 parameter sets the amount of speed decrease that will be applied to the Speed Command in order to lower the heatsink temperature. The decrease in speed will lower the current being switched and conducted by the heat producing output transistors of the iQpump drive.

Parameter L8-19 is set in percentage of maximum frequency (E1-04).

◆ o1 Monitor Configuration

■ o1-01 User Monitor Selection

Setting Range: 6 ~ 94

Factory Default: 6

Setting	Description
6	Output Voltage (<i>factory default</i>)
7	DC Bus Voltage
8	Output Power
10	Input Terminal Status
11	Output Terminal Status
12	Drive Operation Status
13	Cumulative Operation Time
14	Software Number
15	Terminal A1 Input Voltage
16	Terminal A2 Input Voltage
18	Motor Secondary Current (Iq)
20	Output Frequency After Soft Start
24	PI Feedback Value
28	CPU Number
34	First Parameter Causing an OPE
36	PI Input
37	PI Output
38	PI Setpoint
39	Memobus Communication Error Code
40	Heatsink Cooling Fan Operation Time
90	Pump Setpoint
91	Pump Feedback
92	Pump Status
93	Total Setpoint Compensation
94	Motor Speed

■ o1-02 Power-On Monitor

Setting	Description
1	Frequency Reference (<i>factory default</i>)
2	Output Frequency
3	Output Current
4	User Monitor (set by o1-01)

When the iQpump drive is powered up, three monitors are displayed on the digital operator. The first and largest monitor is the “Power-On” monitor. The factory default “Power-On monitor” is Speed Command (U1-01). Below the Speed Command monitor are the next two sequential monitors, Output Frequency (U1-02) and Output Current (U1-03). Pressing the INCREASE key once scrolls the monitors to show the User Monitor as selected by o1-01. The factory default for o1-01 is the Output Voltage monitor (U1-06).

Pump Tuning

The active monitor displayed when the iQpump drive is powered on can be changed to either be U1-01 (Speed Command), U1-02 (Output Frequency), U1-03 (Output Current), or the User Monitor. Whichever monitor is selected as the Power-On top monitor, the two monitors displayed below it are the next two sequential monitors. See example below.

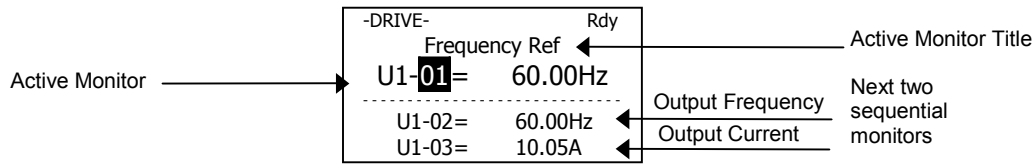

For example, if the iQpump drive needs to display the Elapsed Timer as the Power-On monitor, then o1-01 must be set to “13” and o1-02 must be set to “4.” The next time iQpump drive power is cycled, the digital operator displays U1-13 (Elapsed Time), U1-14 (Flash ID), and U1-15 (Term AI Level).

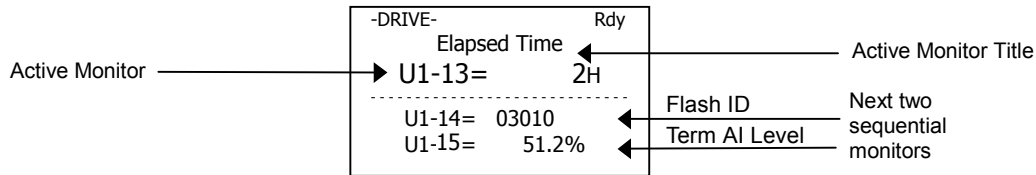

■ o1-05 LCD Contrast Adjustment

Setting Range: 1, 3 or 5
Factory Default: 3

The contrast setting of the LCD display of the digital operator can be adjusted by the setting of parameter o1-05. The higher the number programmed into o1-05, the darker the background will become. Set o1-05 to the value that makes the LCD the easiest to view at the normal viewing distance and angle.

■ o1-06 User Monitor Selection Mode

Setting	Description
0	3 Mon Sequential
1	3 Mon Selectable (<i>factory default</i>)

■ o1-07 Second Line User Monitor

Setting Range: 1 ~ 94
Factory Default: 2

■ o1-08 Third Line User Monitor

Setting Range: 1 ~ 94
Factory Default: 91

Normally the monitors shown directly below the active monitor are the next two sequential monitors. If o1-06 (User Monitor Selection Mode) is set to “1: 3 Mon Selectable,” those two monitors are locked as specified by parameters o1-07 and o1-08 and will not change as the top parameter is scrolled with the INCREASE and DECREASE keys.

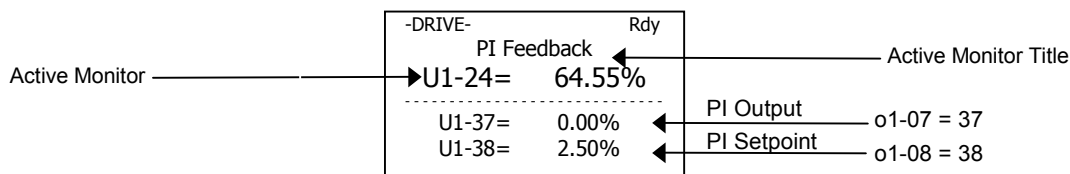

◆ o2 Key Selections

■ o2-06 Operation Selection when Digital Operator is Disconnected

Setting	Description
0	Disabled
1	Enabled (<i>factory default</i>)

Leaving o2-06 enabled will cause the iQpump drive to fault, when the digital operator is removed, even if it's not outputting to the motor. The reset key on the digital operator will need to be pressed after reconnecting the digital operator to reset the fault and continue normal operation.

If o2-06 = "0: Disabled" then the iQpump drive will not fault if the digital operator is disconnected, but the iQpump drive will discontinue motor operation. If full iQpump drive operation is required while the digital operator is removed set o2-06 = "0: Disabled" and o2-15 = "0: Disabled" (Hand Key Function). If both o2-06 and o2-15 are disabled then the digital operator can be disconnected without disturbing iQpump drive operation.

■ o2-07 Cumulative Operating Time Setting

Setting Range: 0 ~ 65535 hours

Factory Default: 0 hours

■ o2-08 Cumulative Operation Time Selection

Setting	Description
0	Power-On Time
1	Running Time (<i>factory default</i>)

The iQpump drive features an Elapsed Timer monitor that records in units of hours. The Elapsed Timer monitor is U1-13. Parameter o2-08 programs this function to either accumulate elapsed hours based on time the iQpump drive is powered (o2-08 = "0: Power-On Time") or time the iQpump drive is running (o2-08 = "1: Running Time"). The iQpump drive is considered "running" anytime there is an active run command or when the iQpump drive is outputting voltage (i.e. including during deceleration).

-DRIVE-	
Elapsed Time	
U1-13 = 0H	
U1-14 =	03010
U1-15 =	34.1 %

Parameter o2-07 allows manual adjustment of the Elapsed Timer, primarily to accommodate maintenance or control board replacement in the event of damage. To reset the Elapsed Timer back to zero, set o2-07 = 0.

◆ o3 Digital Operator Copy Function

■ o3-01 Copy Function Selection

Setting	Description
0	COPY SELECT (<i>factory default</i>)
1	INV → OP READ
2	OP → INV WRITE
3	OP ↔ INV VERIFY

Note: The copy function is disabled when serial communication is active.

■ o3-02 Read Allowed Selection

Setting	Description
0	Disabled (<i>factory default</i>)
1	Enabled

The digital operator has parameter COPY capabilities via built in non-volatile memory. The digital operator can READ all of the parameters in the iQpump drive and store them for later WRITE back to the iQpump drive or into an iQpump drive with the same product code and software number. In order to read the parameter values and store them in the digital operator, select o3-02 = “1: Enabled”. If you attempt to READ the data, which overwrites any previously stored data, without first setting o3-02 = “1: Enabled,” you will get the following error:

-ADV-

PRE
READ IMPOSSIBLE

After setting o3-02 = “1: Enabled,” it is possible to store parameter values in the digital operator by setting o3-01 = 1 (INV→OP READ). A successful READ of the parameter values will display:

-ADV-

READ
READ COMPLETE

An error may occur while saving the parameter values to the digital operator’s memory. If an error is displayed, press any key to cancel the error display and return to parameter o3-01. Error displays and their meanings are covered in Chapter 6: Diagnostics and Troubleshooting of the iQpump Drive Users Manual (TM.iQp.06). To COPY parameter values into a drive, set o3-01 = “2: OPÆ INV WRITE”. During the writing of the parameter values into the iQpump drive the digital operator will display:

-ADV-

COPY
OP→INV COPYING

A successful COPY of the parameter values will display:

-ADV-

COPY
COPY COMPLETE

An error may occur while writing the parameter values to the drive. If an error is displayed, press any key to cancel the error display and return to parameter o3-01. Error displays and their meanings are covered in Chapter 6: Diagnostics and Troubleshooting of the iQpump Drive User Manual (TM.iQp.06).

It is possible to compare the parameter values stored in the digital operator with the parameter values currently in the iQpump drive by using the VERIFY function. This VERIFY function should not be confused with the “-VERIFY-” that is displayed on the digital operator when viewing the “Modified Constants” menu. To VERIFY the parameter values in the iQpump drive as compared with those stored in the digital operator, set o3-01 = “3: OP INV VERIFY”. During the comparing of the parameter values into the iQpump drive the digital operator will display:

-ADV-
VERIFY
 DATA VERIFYING

A successful VERIFY of the parameter values will display:

-ADV-
VERIFY
 VERIFY COMPLETE

If all the parameter values stored in the digital operator do not match those programmed in the iQpump drive, the digital operator displays the following:

-ADV-
VYE
 VERIFY ERROR

The digital operator will not display which parameters did not match, only that the verification found discrepancies in some parameter values.

Note: In order to properly use the COPY or VERIFY functions, the following iQpump drive specifications must be identical between the iQpump drive that the parameters were read from and the iQpump drive that the parameters are to be written to:

- Model Number (e.g. CIMR-P7U2015-107)
- Software Number (e.g. 30030 also known as FLASH ID)

Yaskawa offers DriveWizard™ software that can also READ, COPY, and VERIFY iQpump drive parameter values. DriveWizard™ lists all discrepancies between the iQpump drive and a pre-saved parameter file when verifying is performed.

To use DriveWizard first select o2-15 = “0: Disabled” and select o2-06 = “0: Disabled” then remove the digital operator / keypad and attach the DriveWizard cable in its place.

5.2 Pump Basic

◆ Parameter Overview — P1 Group

Table 5.6

Parameter No.	Address Hex	Parameter Name Digital Operator Display	Description	Range	Default	Menu Location
P1-01	0600	Pump Mode Pump Mode	Select type of control operation. 0: Drive Only (Simplex) 1: Drive + 1 Pump 2: Drive + 2 Pumps 3: Memobus network <0034>	0 ~ 3	0	Programming
P1-02	0601	System Units System Units	0: WC: InchOfWater 1: psi: lb / SqrInch 2: GPM: Gallons / min 3: F: DegFahrenheit 4: CFM: Cubic ft / min 5: CMH: Cubic m / hr 6: LPH: Liters / hr 7: LPS: Liters / s 8: Bar: Bar 9: Pa: Pascals 10: C: DegCelsius 11: Ft: Feet <0032> 12: %: Percent 13: rpm: Revs / min <0034> 14: Hz: Hertz <0034>	0 ~ 14	1	Programming
P1-03	0602	Feedback Device Scaling Fb Dev Scaling	Scaling of feedback device in user units (P1-02=1, e.g. 150 psi). Digits 1 through 4 set the maximum feedback number. Digit 5 determines the number of decimal places. Digit 5 = 0: Number format is XXXX Digit 5 = 1: Number format is XXX.X Digit 5 = 2: Number format is XX.XX Digit 5 = 3: Number format is X.XXX Examples: 01000 = 1000 13000 = 300.0 25000 = 50.00 32000 = 2.000	1 ~ 36000 (system units P1-02)	00145	Programming

◆ P1 Pump Minimum Speed and No-Flow Detection

The iQpump drive can be programmed to operate the pump motor at a user set minimum speed and has three independent built-in functions to protect the pump against a no-flow condition.

The following sections describe each of these functions.

■ Set Minimum Pump Speed (P1-06)

The required minimum operating speed of the pump motor can be set with Parameter P1-06 Minimum Pump Frequency.

Table 5.7

Parameter No.	Address Hex	Parameter Name Digital Operator Display	Description	Range	Default	Menu Location
P1-06 ◆	0605	Minimum Pump Frequency Min. Pump Freq.	Minimum drive frequency when operated in the auto mode. Programmed value will limit minimum PID output. Minimum value has to be programmed to a value smaller than P3-09 and P3-10 when the drive is operating in the multiplex mode (P1-01).	0 ~ 120 Hz	40.0 Hz	Pump Quick Setup
◆ Denotes that parameter can be changed when the drive is running.						

Example: 3600 rpm Pump Motor

Desired Operation: Minimum Speed is 2400 rpm

Solution: Program P1-06 to 40.0 Hz ($2400 \div 3600 \times 60 \text{ Hz (E1-04)} = 35.0 \text{ Hz}$)

Example: 1800 rpm Pump Motor

Desired Operation: Minimum Speed is 1000 rpm

Solution: Program P1-06 to 33.3 Hz ($1000 \div 1800 \times 60 \text{ Hz (E1-04)} = 33.3 \text{ Hz}$)

◆ P1 Loss of Prime Detection <0032>

■ P1-14, P1-16

The Loss of Prime function can be used to detect a pump system **low suction** condition. The iQpump drive continuously monitors pump motor current and output frequency while operating auto mode.

■ Enable Loss of Prime Function

Program P1-14 Prime Loss Level to low suction condition current level.

Guideline: Use 40 % of the pump motor full load amp rating (Parameter E2-01)

■ Operation

If the iQpump drives' output frequency is at maximum (Parameter E1-04) and the pump motor output current level drops below P1-14 Prime Loss Level for the time programmed in P1-16 Loss of Prime Time the iQpump drive will fault and display "LOP".

Prime Loss Time: The "Prime Loss" detection is no longer controlled by parameter P1-12. Instead it is controlled by a new parameter, P1-16. Also, the "Prime Loss" detection is enabled during the pre-charge function, but only when not ramping (output frequency = pre-charge frequency).

- Parameter P1-16 is used as the "Loss of Prime" fault timer.
- Parameter P1-16 should be enabled when in pre-charge, but only when the output frequency is within 1 Hz of the pre-charge frequency.
- Loss of Prime Detection is allowed when output frequency is within 1 Hz of d2-01 value instead of the fmax value.
- Loss of Prime Detection is allowed regardless of how many pumps are staged (contactor multiplex operation).
- Loss of Prime is enabled during Timed Run and Run / Stop Control.

Table 5.8

Parameter No.	Address Hex	Parameter Name Digital Operator Display	Description	Range	Default	Menu Location
P1-14 ◆	0109	Prime Loss Level Prime Loss Level	Used to detect loss of prime in the pump. If output current drops below this level for the time specified in P1-12 and the output frequency is at fmax, a "Loss Of Prime" fault occurs. The drive will coast to a stop when a fault occurs.	0 ~ 1000.0 A	0.0 A	Programming
P1-16 ◆ <0034>	87F	Loss of Prime Time Prime Loss Time	Delay time before a Loss of Prime fault occurs. Pump protection criteria specified P1-14 must be met for the drive to fault. On fault the drive will coast to a stop.	1 ~ 600 s	20 s	Programming

◆ Denotes that parameter can be changed when the drive is running.

Note: Loss of prime function is only active when the maximum numbers of pumps defined by P1-01 are running at maximum frequency.

-DRIVE-	
Loss of Prime	
LOP	
U2-04 =	0.00 Hz
U2-05 =	0.00 A

Figure 5.50 Loss of Prime (LOP) Fault

5.2 Pump Basic

Fault Display	Description	Cause	Countermeasures
LOP Loss of Prime	Loss of Prime Fault- Pump has lost its prime.	If the output current drops below the P1-14 Prime Loss Level for the time specified in P1-16 and the output frequency is at a high enough level, Possible causes: Dry Well, Air in System, No Water	Allow the system to pump water again (must have resistance in pump).

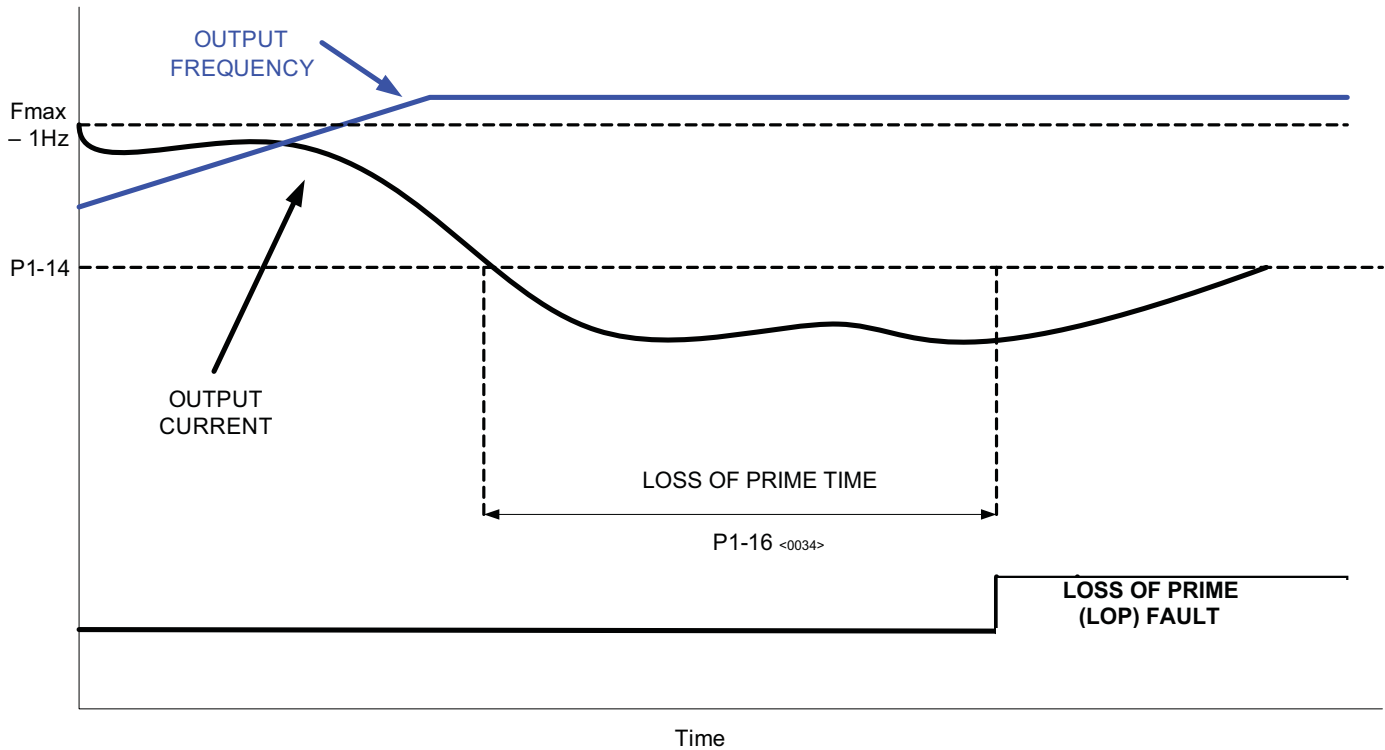

Figure 5.51 Loss of Prime (LOP) Fault

Note: Loss of prime function is only active when the maximum number of pumps defined by P1-01 running at maximum frequency. Loss of prime function is only active in auto mode.

5.3 Pump Protection

◆ P2 Shutdown Pump System When Running at Low Speed (Sleep)

■ P2-01, P2-02, P2-03

To protect the pump from operating at very low speeds causing excessive pump wear the iQpump drive offers a function to shutdown (Sleep) the pump system.

■ Select Signal to Monitor

The system level to monitor no-flow operation can be selected with parameter *P2-01 Sleep Level Type*:

Table 5.9

Parameter No.	Address Hex	Parameter Name Digital Operator Display	Description	Range	Default	Menu Location
P2-01	060A	Sleep Level Type Sleep Lvl Type	Sets the sleep type. 0: Output Frequency 1: Output Current 2: Feedback 3: Output Speed (rpm) <0034> 4: Low Flow (Terminal A1 - Flow meter required) <0034> Note: Feedback depends on PID direction operation. Displays a “Sleep” Alarm when active.	0 ~ 4	0	Programming
P2-02 ◆	060B	Sleep Level Sleep Level	Sleep activates when selected level (P2-01) reaches programmed sleep level for time specified in P2-03. The level type is determined by P2-01. A value of 0 disables this function. This function is only active during running while operating in auto mode. If P1-01 = 3, the function is active when there is only one drive running on the network. <0034> Display Units for Sleep Level P2-02 when P2-01 is programmed for the following: P2-01 = 0: Display based on “Hz” P2-01 = 1: Display based on “A” P2-01 = 2: Display based on P1-02 Selection P2-01 = 3: Display based on “rpm” <0034> P2-01 = 4: Display based on P6-02 Selection <0034> Note: When P2-01 is set for a value of 2, display units will be dependent on P1-02 setting. If P2-02 = 0, pump will sleep at minimum speed.	0.0 ~ 6000.0	0.0	Programming
P2-03 ◆	060C	Sleep Delay Time Sleep Delay Time	Delay time before the drive enters sleep mode when criteria is met as defined by parameter P2-02.	0 ~ 3600	5 s	Programming

◆ Denotes that parameter can be changed when the drive is running.

■ Setup Sleep Level (P2-02)

Sleep Detection level can be setup with *P2-02 Sleep Level*. The Sleep Level units for P2-02 depend on the selection of parameter P2-01 (System Units).

5.3 Pump Protection

■ Sleep Function Based on Output Frequency (P2-01 = 0)

The iQpump drive enters sleep mode when the output frequency falls below the level programmed in P2-02 for a time specified in P2-03.

Note: In order for the sleep function to become active the output frequency has to rise above the programmed level P2-02 first or above the Sleep Active Level (P2-20) when programmed to a value greater than 0.0 Hz.

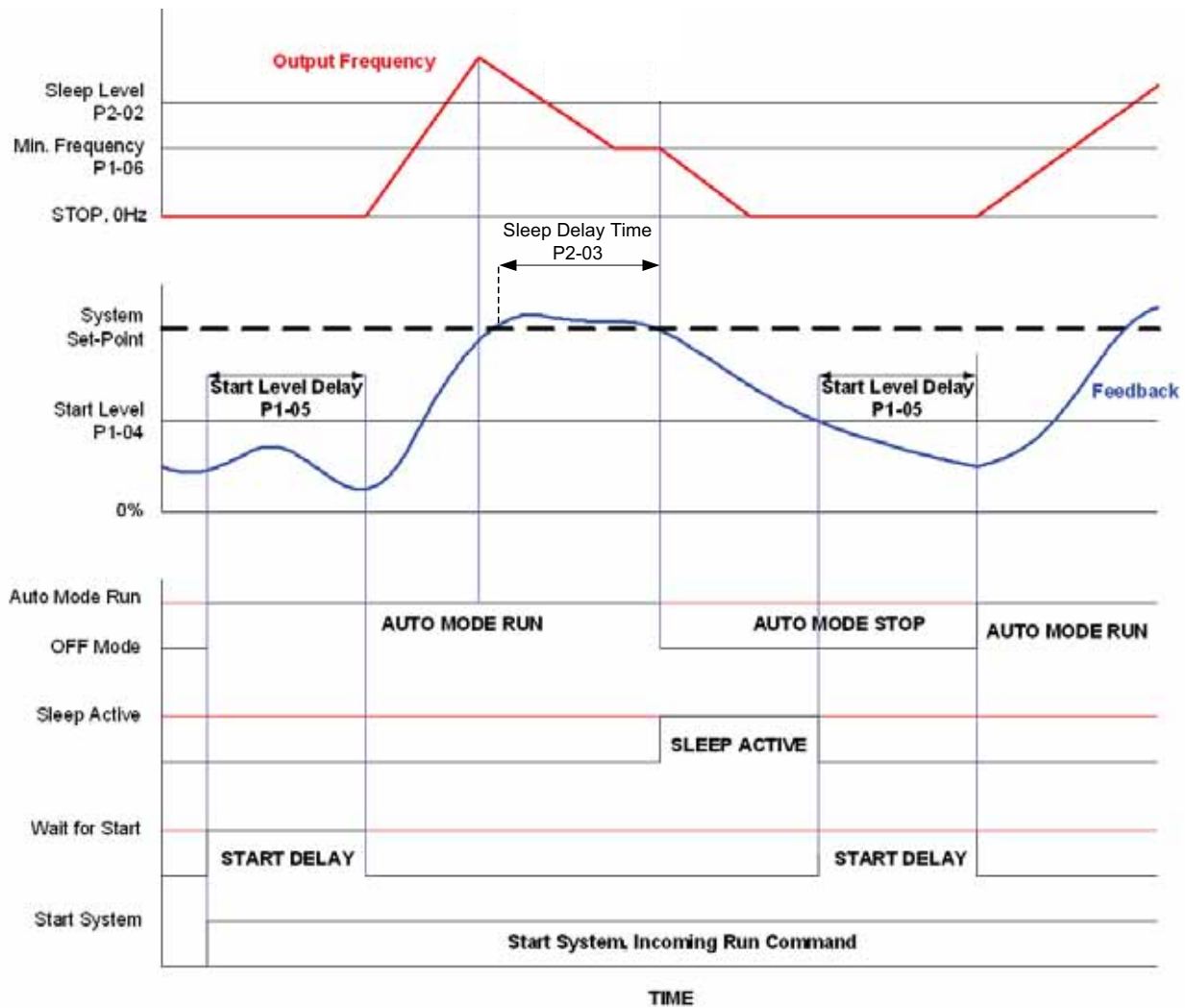

Figure 5.52 Sleep Function Based on Output Frequency

■ Sleep Function Based on Output Current (P2-01 = 1)

The iQpump drive enters sleep mode when output current falls below level programmed in P2-02 for a time specified in P2-03.

Timing Chart: Start Level Operation

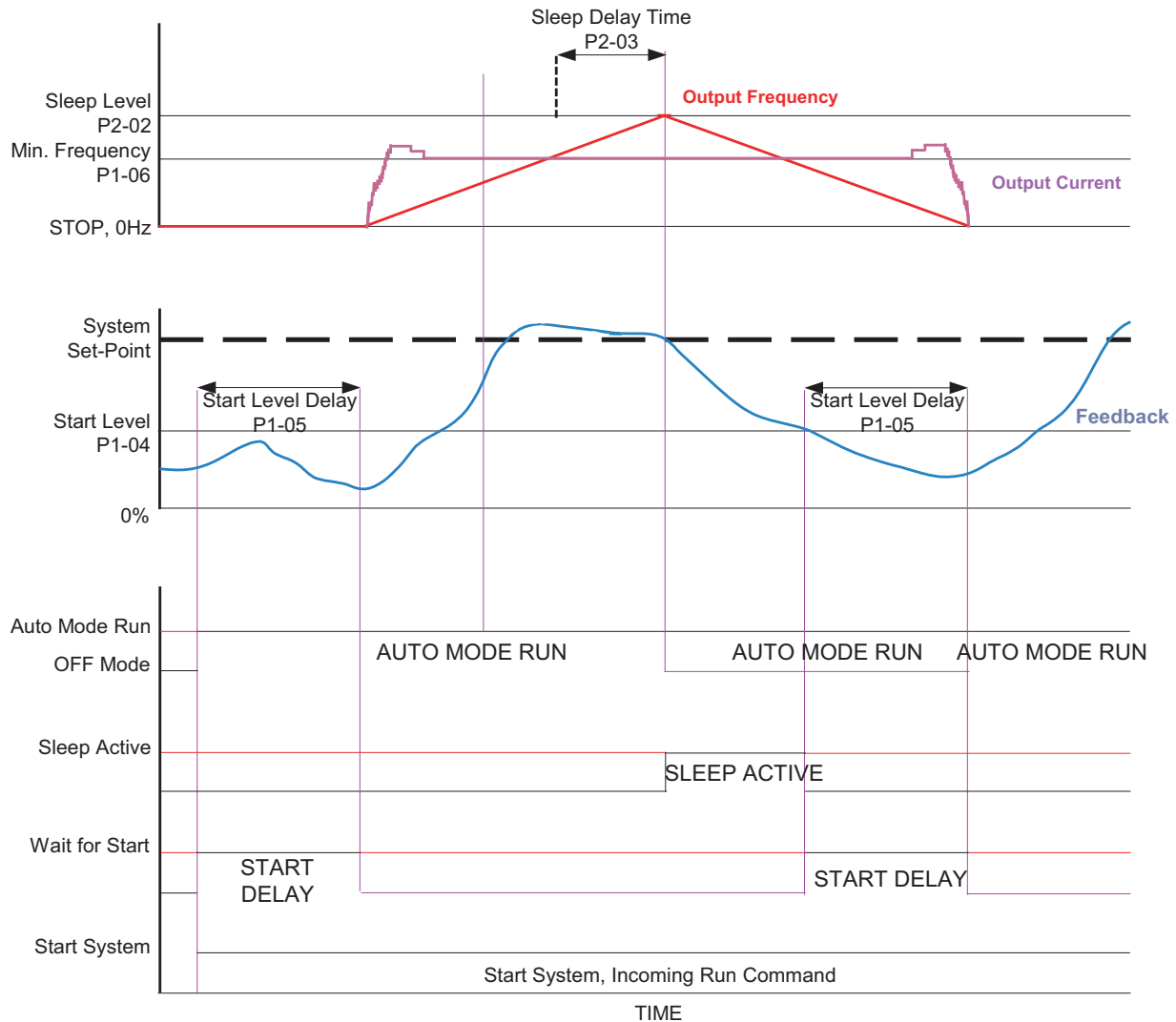

Figure 5.53 Sleep Function Based on Output Current

■ Sleep Function Based on Feedback Level (P2-01 = 2)

The iQpump drive enters sleep mode when feedback signal rises above the level programmed in P2-02 for a time specified in P2-03. When Pi operation direction (*B5-09 Output Level Selection*) is set for Reverse Output, sleep mode will check for the feedback signal to fall below P2-02.

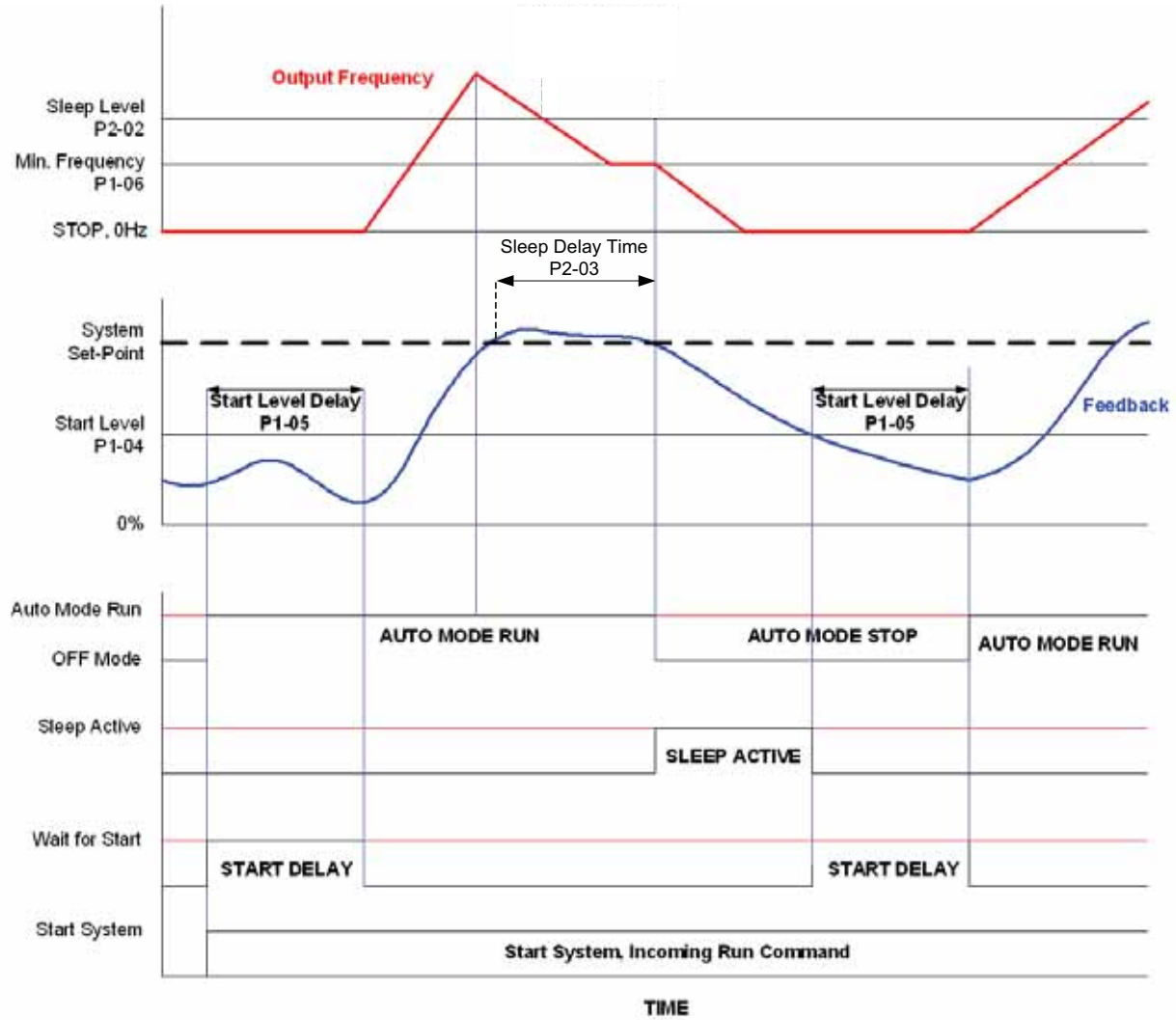

Figure 5.54 Sleep Function Based on Feedback Level

5.4 T1 Auto-Tuning

◆ T1-02 Motor Rated Power

Setting Range: 0.00 ~ 650.00 kW

Factory Default: Model Dependent

◆ T1-04 Motor Rated Current

Setting Range: Model Dependent

Factory Default: Model Dependent

Auto tuning is recommended to achieve optimum performance. In addition, the iQpump drive requires Line-To-Line Resistance auto-tuning before it can properly perform the Estimated Speed Search method. This method of speed search allows for bi-directional speed search. The T1 parameters are found under the Auto-Tuning menu.

To perform auto-tuning follow these steps:

1. T1-02 should be left at the default value (the last 3 digits of the iQpump drive model number).
2. In T1-04, enter the Full Load Amps (FLA) as stamped on the motor's nameplate.
3. Press the INCREASE key once to display this:

```

-ATUNE-          Rdy
-----
Auto-Tuning
0Hz/ 0.00A
Tuning Ready ?
Press HAND key
  
```

4. If ready, press the HAND key once to start auto-tuning. This process will last for approximately 15 seconds. Once auto-tuning is finished, the digital operator will display this:

```

-ATUNE-
-----
Tune Successful
0Hz/ 0.00A
  
```

5. To exit the Auto-Tuning menu, press the MENU key once.

It is possible to get a "Data Invalid" error if the either T1-02 or T1-04 fall outside the range of what the iQpump drive will accept as reasonable levels for the programmed size of iQpump drive (o2-04).

THIS PAGE INTENTIONALLY BLANK



Diagnosics & Troubleshooting

This chapter describes diagnostics and troubleshooting for the iQpump drive.

6.1 Fault Detection	138
6.2 iQpump Keypad Messages	143
6.3 Alarm Detection	145
6.4 Operator Programming Errors (OPE)	148
6.5 Auto-Tuning Faults	149
6.6 Digital Operator COPY Function Faults	150
6.7 Troubleshooting	151
6.8 Main Circuit Test Procedure	155
6.9 Drive Date Stamp Information	158

6.1 Fault Detection

When the iQpump drive detects a fault, the fault information is displayed on the digital operator, the fault contact closes, and the motor coasts to stop. (However, a fault with selectable stopping method will operate according to the stopping method selected.)

- If a fault occurs, take appropriate action according to the table by investigating the cause.
- To restart, reset the fault with any of the following procedures:
 - Turn ON the fault reset signal.
 - Set “14: Fault Reset” to a multi-function digital input (H1-01 to H1-05).
 - Press the RESET key of the digital operator.
 - Shut off the iQpump drive input power once, and then turn on again.

WARNING

The Run Command (Start Command) needs to be removed prior to resetting a fault. Resetting a fault by removing and reapplying power to the iQpump drive while the Run Command is applied, may cause the iQpump drive to start unexpectedly. Therefore, make sure all personnel are clear from the iQpump drive, motor, and machine prior to resetting the iQpump drive.

Table 6.1 Fault Displays and Processing

Digital Operator Display	Description	Cause	Corrective Action
bUS Option Com Err	Option Communication Error After initial communication was established, the connection was lost.	Connection is broken, master has stopped communicating.	Check all connections, verify all user-side software configurations.
CE Memobus Com Err	Modbus Communication Error Control data was not received correctly for two seconds.	Connection is broken, master has stopped communicating.	Check all connections, verify all user-side software configurations.
CPF00 COM- ERR(OP&INV)	Operator Communication Fault 1 Transmission between the iQpump and the digital operator cannot be established within 5 seconds after supplying power.	Digital operator cable not securely connected, digital operator defective, control board defective.	Remove the digital operator once and then reinstall it.
	External RAM of CPU is defective.	Control circuit damage.	Cycle power off and on to the iQpump. Replace the iQpump.
CPF01 COM- ERR(OP&INV)	Operator Communication Fault 2 After communication started with the digital operator, a communication fault occurred for 2 seconds or more.	Digital operator cable not securely connected, digital operator defective, control board defective.	Remove the digital operator once and then reinstall it. Cycle power off and on to the iQpump. Replace the iQpump.
	CPF02 BB Circuit Err	Baseblock Circuit Fault Baseblock circuit fault at power-up.	Perform a factory initialization.
			Cycle power off and on to the iQpump. Replace the control board.
CPF03 EEPROM Error	EEPROM Fault EEPROM fault, check sum not valid.	Noise or spike on the control circuit input terminals.	Perform a factory initialization.
			Cycle power off and on to the iQpump.
			Replace the control board.
CPF04 Internal A/D Err	CPU Internal A/D Converter Fault	Noise or spike on the control circuit input terminals.	Perform a factory initialization.
			Cycle power off and on to the iQpump.
			Replace the control board.
CPF05 External A/D Err	CPU External A/D Converter Fault	Noise or spike on the control circuit input terminals.	Perform a factory initialization.
			Cycle power off and on to the iQpump.
			Replace the control board.
CPF07 RAM-Err	ASIC Internal RAM Fault (RAM)	—	Cycle power off and on to the iQpump.
		Control circuit damage.	Replace the iQpump.

Digital Operator Display	Description	Cause	Corrective Action
CPF08 WAT-Err	Watchdog Timer Fault (WAT)	—	Cycle power off and on to the iQpump.
		Control circuit damage.	Replace the iQpump.
CPF09 CPU-Err	CPU-ASIC Mutual Diagnosis Fault (COY)	—	Cycle power off and on to the iQpump.
		Control circuit damage.	Replace the iQpump.
CPF10 ASIC-Err	ASIC Version Fault (ASIC)	Control circuit damage.	Replace the iQpump.
CPF20 Option A/D Error	Option Card Fault	Option card connector connection fault.	Remove all inputs to the option board.
		Option card A/D converter fault.	Perform a factory initialization.
			Cycle power off and on to the iQpump.
			Replace the option board.
CPF21 Option CPU Down	Self-diagnosis Fault of Communication Option Card	Noise or spike on the communication line, defective option board.	Replace the control board.
			Perform a factory initialization.
			Cycle power off and on to the iQpump.
			Replace the option board.
CPF22 Option Type Err	Communication Option Card Code Number Fault	Unrecognizable option board is connected to the control board.	Replace the control board.
			Remove any option boards.
			Cycle power off and on to the iQpump.
			Perform a factory initialization.
CPF23 Option DPRAM Err	Communication Option Card Interconnection Fault	An option board is not correctly connected to the control board or an option board that is not made for the iQpump is attached to the control board.	Replace the option board.
			Replace the control board.
			Remove power to the iQpump.
			Connect the option board once more.
			Perform a factory initialization.
EF0 Opt External Flt	Communication Option Card External Fault	An external fault condition exists.	Cycle power off and on to the iQpump.
			Replace the option board.
			Replace the control board.
EF3 Ext Fault S3	External Fault at Terminal S3	An external fault condition exists connected to a multi-function digital input.	Eliminate the cause of an external fault condition.
EF4 Ext Fault S4	External Fault at Terminal S4		
EF5 Ext Fault S5	External Fault at Terminal S5		
EF6 Ext Fault S6	External Fault at Terminal S6		
EF7 Ext Fault S7	External Fault at Terminal S7		
FbL Feedback Loss	PI Feedback Loss This fault occurs when PI Feedback Loss Detection is programmed to fault (b5-12 = 2) and the PI Feedback < PI Feedback Loss Detection Level (b5-13) for the PI Feedback Loss Detection Time (b5-14).	PI Feedback source (e.g. transducer, sensor, building automation signal) is not installed correctly or is not working.	Remove the fault from a multi-function digital input.
			Verify iQpump is programmed to receive the PI Feedback source signal.
GF Ground Fault	Output Ground Fault iQpump output grounding current has exceeded 50 % of the iQpump rated output current.	Motor lead is shorted to ground, DCCT defective.	Check to ensure the PI Feedback source is installed and working properly.
			Remove the motor and run the iQpump without the motor.
			Check the motor for a phase-to-ground short.
			Check the output current with a clamp on meter to verify the DCCT reading.

6.1 Fault Detection

Digital Operator Display	Description	Cause	Corrective Action
LF Output Phase Loss	Output Open-phase An open-phase occurred at the iQpump output. This fault is detected when output current has exceeded 5 % imbalance.	There is a broken wire in the output cable.	Check the wiring to the motor.
		There is a broken wire in the motor winding.	Check the motor for phase-to-ground short.
		The output terminals were loose.	
		The motor being used has a capacity less than 5 % of the iQpump's maximum motor capacity.	Check the motor and iQpump capacity.
		Low impedance motor was used.	Add additional impedance.
Parameter E2-03 set incorrectly.	Adjust E2-03 to a lower value.		
LL3 Loss of Load Det 1	Loss of Load Detection 1 iQpump output current < L6-02 for more than the time set in L6-03.	Motor is underloaded.	Ensure the values in L6-02 and L6-03 are appropriate.
			Check application / machine status to eliminate fault.
oC Over Current	Overcurrent iQpump output current exceeded the overcurrent detection level (approximately 180 % of iQpump rated output current).	Shorted iQpump output phase-to-phase, shorted motor, locked rotor, load too heavy, accel / decel time too short, contactor on the iQpump output is opened and closed, a special motor or a motor with a FLA rating larger than iQpump rated output current.	Remove the motor and run the iQpump without the motor.
			Check the motor for a phase-to-phase short.
			Check the iQpump for a phase-to-phase short at the output.
			Verify C1-01 to C1-06 are set correctly.
			Check load conditions.
oH1 Heatsink MAX Temp	Cooling Fin / Cooling Fin Fan Overheat The temperature of the iQpump cooling fin exceeded the temperature programmed in parameter L8-02, and L8-03 = 0-2.	Cooling fan(s) are not working, high ambient temperature, a heat source is too close to the iQpump.	Check for dirt build-up on the fans and cooling fins.
	iQpump Internal Cooling Fan.		Reduce the ambient temperature around the iQpump. Remove the heating unit / Replace the cooling fan.
oH3 Motor Overheat 1	Motor Overheating Alarm The iQpump stops or continues operation according to the setting of L1-03.	Overheating of motor as measured by motor thermistor.	Recheck the cycle time and the size of the load.
			Recheck the accel / decel time (C1-01 to C1-06).
			Recheck the V/f pattern (E1-01 thru E1-13).
			Recheck the motor rated current value (E2-01).
oH4 Motor Overheat 2	Motor Overheating Fault The iQpump stops operation according to the setting of L1-04.	Overheating of motor as measured by motor thermistor.	Recheck the cycle time and the size of the load.
			Recheck the accel / decel time (C1-01 to C1-06).
			Recheck the V/f pattern (E1-01 thru E1-13).
			Recheck the motor rated current value (E2-01).
oL1 Motor Overloaded	Motor Overload Designed to protect the motor. Fully adjustable from parameter E2-01.	The load is too large. The cycle time is too short at the accel / decel time.	Recheck the cycle time and the size of the load as well as the times set in C1-01 and C1-03 to C1-06.
		The voltage of the V/f pattern is high.	Review the V/f pattern parameters, E1-01 thru E1-13.
		Motor rated current setting is improper.	Check the motor rated current value in E2-01.

Digital Operator Display	Description	Cause	Corrective Action
oL2 Inv Overloaded	iQpump Overload Designed to protect the iQpump.	The load is too large. The cycle time is too short at the accel / decel time.	Recheck the cycle time and the size of the load as well as the times set in C1-01 and C1-03 to C1-06.
		The voltage of the V/f pattern is high.	Review the V/f pattern parameters, E1-01 thru E1-13.
		The size of the iQpump is small.	Change to a larger size iQpump.
oL3 Overtorque Det 1	Overtorque Detection 1 iQpump output current > L6-02 for more than the time set in L6-03.	Motor is overloaded.	Ensure the values in L6-02 and L6-03 are appropriate.
			Check application / machine status to eliminate fault.
oPR Oper Disconnect	Digital Operator Connection Fault The iQpump will stop if the digital operator is removed when the iQpump is commanded to run through the digital operator.	The digital operator is not attached or the digital operator connector is broken.	Attach the digital operator.
			Check the digital operator connector.
			Verify the setting of o2-06.
oV DC Bus Overvolt	DC Bus Overvoltage 208-240 Vac: Trip point is ≥ 400 Vdc. 480 Vac: Trip point is ≥ 800 Vdc.	High input voltage at R/L1, S/L2 and T/L3.	Check the input circuit and reduce the input power to within specifications
		The deceleration time is set too short.	Extend the time in C1-02, C1-04 or C1-06.
		Power factor correction capacitors are being used on the input to the iQpump.	Remove the power factor correction capacitors.
PF Input Pha Loss	Input Phase Loss iQpump input power supply has an open phase or has a large imbalance of input voltage.	Open phase on input of the iQpump.	Check the input voltage.
		Loose terminal screws at R/L1, S/L2 or T/L3.	Tighten the terminal screws.
		Momentary power loss occurred.	Check the input voltage.
		Input voltage fluctuation too large.	Check the input voltage.
		Parameter L8-06 value is set incorrectly.	Verify parameter L8-06 is set correctly per the kVA tables on pages C-2 and C-3. Adjust L8-06 according to your application. The higher the value the less sensitive it becomes. CAUTION: Changing this parameter from the factory default setting may cause iQpump failure and void the product warranty. (Consult the factory for application assistance).
PUF DC Bus Fuse Open	DC Bus Fuse Detects if the DC bus fuse has opened.	Shorted output transistor(s) or terminals.	Remove power from the iQpump.
			Disconnect the motor.
			Perform the checks without power in Table 6.6.
			Replace the shorted component(s).
rH DynBrk Resistor	Dynamic Braking Resistor The protection of the dynamic braking resistor based on setting of L8-01.	Overhauling load, extended dynamic braking duty cycle, defective dynamic braking resistor.	Replace the defective fuse.
			Verify dynamic braking duty cycle.
			Monitor DC bus voltage.
			Replace dynamic braking resistor.
rr DynBrk Transistr	Dynamic Braking Transistor The dynamic braking transistor failed.	Shorted dynamic braking transistor, high DC bus voltage, defective dynamic braking resistor.	Cycle power off and on to the iQpump.
			Replace defective dynamic braking transistor or resistor.
			Monitor DC bus voltage.
Uv1 DC Bus Undervolt	DC Bus Undervoltage The DC bus voltage is \leq L2-05. 208-240 Vac: Trip point is ≤ 190 Vdc. 480 Vac: Trip point is ≤ 380 Vdc.	Low input voltage at R/L1, S/L2 and T/L3.	Check the input circuit and increase the input power to within specifications.
		The acceleration time is set too short.	Extend the time in C1-01, C1-03, or C1-05.
		Voltage fluctuation of the input power is too large.	Check the input voltage.

6.1 Fault Detection

Digital Operator Display	Description	Cause	Corrective Action
Uv2 CTL PS Undervolt	Control Power Supply Undervoltage Undervoltage of the control circuit when running.	External load connected pulling down the iQpump power supplies.	Cycle power off and on to the iQpump.
			Repair or replace the Power PCB / Gate iQpump PCB.
			Remove all control wiring and test iQpump.
Uv3 MC Answerback	Soft Charge Circuit Fault The pre-charge contactor opened while the iQpump was running.	Contacts on the soft charge contactor are dirty and the soft charge contactor does not function mechanically.	Cycle power off and on to the iQpump.
			Check the condition of the soft charge contactor.
			Repair or replace the Power PCB / Gate iQpump PCB.

WARNING

Some features within the PI function group cause the iQpump to shut down momentarily (e.g. Sleep Function, Snooze Function, Feedback Loss feature etc.) Upon recovery from the conditions that activate these features, the iQpump may start unexpectedly. Therefore, when enabling these features take appropriate measures to notify personnel working with this equipment that unexpected starting may occur.

6.2 iQpump Keypad Messages

◆ Pump Fault and Alarm Messages

The iQpump has a comprehensive set of dedicated pump alarms and faults that will alert the operator when the pump system has experienced any problems. A warning or fault message on the operator display indicates abnormal iQpump drive status.

■ Pump Fault Messages Generated

Table 6.2 Pump Fault Messages Generated

Digital Operator Display	Description	Cause	Corrective Action
EF1-7 Pump Fault S#	External Pump Fault	Digital input is closed.	Check incoming digital signal from external device.
FbL Feedback Loss <0032>	PI Feedback Loss This fault occurs when PI Feedback Loss Detection is programmed to fault (b5-12 = 2) and the PI Feedback < PI Feedback Loss Detection Level (b5-13) for the PI Feedback Loss Detection Time (b5-14).	PI Feedback source (e.g. transducer, sensor, building automation signal) is not installed correctly or is not working.	Verify iQpump is programmed to receive the PI Feedback source signal. Check to ensure the PI Feedback source is installed and working properly.
HFb High Feedback	High Feedback Fault Feedback signal is too high.	The feedback level has risen above P1-09 level for the time specified in P1-10. High feedback fault is active in Hand Mode, Auto Mode, Pre-charge and Thrust Mode when the drive is running.	Feedback level lower than the high feedback level (P1-09).
LFb / LW Low FB / Water	Low Feedback Level Fault Feedback signal is too low or water low input closed.	The feedback level has dropped below P1-07 for the time specified in P1-08 or water low input is active. Low feedback fault is active in Auto Mode when the iQpump is running. Digital input is closed.	Feedback level greater than the low feedback level (P1-07). Check incoming digital signal from external device.
LoP Loss of Prime <0032>	Loss of Prime Fault Pump has lost its prime.	If the output current drops below the P1-14 Prime Loss Level for the time specified in P1-16 and the output frequency is at fmax, a “Loss of Prime (LOP)” fault occurs Possible cause: Dry Well, Air in System, No Water	Allow system to pump water again (must have resistance in pump).
nMS Set Point Not Met <0032>	Not Maintaining Set Point Fault Set Point cannot be maintained.	When the setpoint cannot be maintained for a time specified in P1-12, a “Not Maintaining Setpoint (NMS)” fault occurs. The function is disabled when the drive is not running and the PID is not active. Possible cause: Blocked Impeller, Over-Cycling, Broken Pipe	Reduce the difference between the setpoint and the feedback smaller than the Maximum Setpoint Difference (P1-11).
oPE12 <0032>	Thermostat Fault Selection Fault	Both Normally Open (H1-xx = 83) and the Normally Closed (H1-xx = 87) Thermostat Fault inputs have been programmed	Only use one of the two fault inputs.

6.2 iQpump Keypad Messages

Digital Operator Display	Description	Cause	Corrective Action
PoC Pump Over Cycle	Pump Over Cycle Protection	VFD Controlled Pump exceeds number of Normal Operation to Sleep Mode Cycles. Cycle limit (P2-09) for time specified in P2-10.	Adjust sleep parameters to prevent system from cycling.
THMS Thermostat	Thermostat Fault	Digital input is closed.	Check incoming digital signal from external device.

6.3 Alarm Detection

The alarms are iQpump drive protection functions that do not operate the fault contact. The iQpump drive will automatically return to its original status once the cause of the alarm has been removed.

During an alarm condition, the digital operator display flashes and an alarm output is generated at the multi-function outputs (H2-01 to H2-02) if programmed.

When an alarm occurs, take appropriate corrective action according to the table below.

Table 6.3 Alarm Displays and Processing

Digital Operator Display	Description	Cause	Corrective Action
bUS Option Com Err	Option Communication Error After initial communication was established, the connection was lost.	Connection is broken, master has stopped communicating.	Check all connections, verify all user side software configurations.
CALL SI-F / G ComCall	Serial communication transmission error. Communication has not yet been established.	Connection not made properly, user software not configured to the proper baud rate or configuration.	Check all connections, verify all user side software configurations.
EF External Fault	External fault at terminals S1 and S2 Both the forward and the reverse run commands are input simultaneously for 500mS or more. This alarm stops the motor.	An external forward and reverse command are input simultaneously.	Check external sequence logic.
EF0 Opt External Flt (Flashing)	Communication Option Card External Fault	An external fault condition exists.	Check for an external condition. Verify the parameters. Verify communication signal.
EF3 Ext Fault S3 (Flashing)	External Fault at Terminal S3	An external fault condition exists connected to a multi-function digital input.	Eliminate the cause of an external fault condition.
EF4 Ext Fault S4 (Flashing)	External Fault at Terminal S4		
EF5 Ext Fault S5 (Flashing)	External Fault at Terminal S5		
EF6 Ext Fault S6 (Flashing)	External Fault at Terminal S6		
EF7 Ext Fault S7 (Flashing)	External Fault at Terminal S7		
dnE iQpump not Enable (Flashing)	iQpump enable command missing. The iQpump does not have the enable command when the run command is applied.	The Run command has been applied prior to the enable signal.	Apply the enable command before applying the run command.
FAn Cooling Fan Error	Failure of the iQpump internal cooling fan when L8-32 = 0.	iQpump cooling fan has stopped.	Replace the cooling fan.
FbL Feedback Loss <0032>	PI Feedback Loss This fault occurs when PI Feedback Loss Detection is programmed to fault (b5-12 = 2) and the PI Feedback < PI Feedback Loss Detection Level (b5-13) for the PI Feedback Loss Detection Time (b5-14).	PI feedback source (e.g. transducer, sensor, building automation signal) is not installed correctly or is not working.	Verify iQpump is programmed to receive the PI feedback source signal. Check to ensure the PI feedback source is installed and working properly. Check the motor for a phase-to-phase short. Check the iQpump for a phase-to-phase short at the output. Verify C1-01 to C1-06 are set correctly. Check load conditions.

6.3 Alarm Detection

Digital Operator Display	Description	Cause	Corrective Action
LL3 Loss of Load Det 1 (Flashing)	Loss of Load Detection 1 iQpump output current < L6-02 for more than the time set in L6-03.	Motor is underloaded.	Ensure the values in L6-02 and L6-03 are appropriate.
			Check application / machine status to eliminate fault.
oH Heatsnk Overtemp (Flashing)	Cooling Fin / Cooling Fin Fan Overheat The temperature of the iQpump cooling fin exceeded the temperature programmed in parameter L8-02.	Cooling fan(s) are not working, high ambient temperature, a heating unit in close proximity to iQpump is present.	Check for dirt build-up on the fans and cooling fins.
	iQpump Internal Cooling Fan.		Reduce the ambient temperature around the iQpump. Remove the heating unit.
oH2 Over Heat 2 (Flashing)	iQpump overheat pre-alarm signal is input from a multi-function digital input terminal.	An external overheat condition exists connected to one of the multi-function input terminals S3, S4, S5, S6 or S7.	Check for an external condition. Verify the program parameters H1-01 thru H1-05.
oH3 Motor Overheat 1 (Flashing)	Motor Overheating Alarm The iQpump stops or continues operation according to the setting of L1-03.	Overheating of motor.	Recheck the cycle time and the size of the load.
			Recheck the accel / decel time (C1-01 to C1-06).
			Recheck the V/f pattern (E1-01 thru E1-13).
			Recheck the motor rated current value (E2-01).
			Check the digital operator connector.
			Verify the setting of o2-06.
ov DC Bus Overvolt (Flashing)	DC Bus Overvoltage 208-240 Vac: Trip point is ≥ 400 Vdc. 480 Vac: Trip point is ≥ 800 Vdc.	High input voltage at R/L1, S/L2 and T/L3.	Check the input circuit and reduce the input power to within specifications.
		The deceleration time is set too short.	Extend the time in C1-02, C1-04, or C1-06.
		Power factor correction capacitors are being used on the input to the iQpump.	Remove the power factor correction capacitors.
PrHT Motor Preheating	Motor Preheating Motor is preheating.	Motor Preheat 2 input is closed.	—
Uv DC Bus Undervolt (Flashing)	DC Bus Undervoltage The DC bus voltage is \leq L2-05. 208-240 Vac: Trip point is ≤ 190 Vdc. 480 Vac: Trip point is ≤ 380 Vdc.	Low input voltage at R/L1, S/L2 and T/L3.	Check the input circuit and increase the input power to within specifications.
		The acceleration time is set too short.	Extend the time in C1-01, C1-03, or C1-05.
		Voltage fluctuation of the input power is too large.	Check the input voltage.
Uv2 CTL PS Undervolt	Control Power Supply Undervoltage of the control circuit when running.	External load connected pulling down the iQpump power supplies.	Cycle power off and on to the iQpump. Repair or replace the Power PCB / Gate iQpump PCB.
Uv3 MC Answerback	Soft Charge Circuit Fault The pre-charge contactor opened while the iQpump was running.	Contacts on the soft charge contactor are dirty and the soft charge contactor does not function mechanically.	Cycle power off and on to the iQpump. Check the condition of the soft charge contactor.

◆ Pump Alarm Messages Generated

Digital Operator Display	Description	Cause	Corrective Action
Low Feedback Low FB Sensed	Low Feedback Level Alarm Feedback signal is too low.	The feedback level has dropped below the low feedback level (P1-07). Low feedback fault is active in Auto Mode when the iQpump drive is running.	Feedback level greater than the low feedback level (P1-07).
High Feedback High FB Sensed	High Feedback Alarm Feedback signal is too high.	The feedback level has risen above P1-09 level. High feedback alarm is active in Hand Mode, Auto Mode, Pre-charge and Thrust Mode when the iQpump drive is running.	Feedback level lower than the high feedback level (P1-09).
Start Delay Timer Active	Start Delay Start delay timer is active.	Displays when the iQpump drive is about to start. The feedback level is fallen below the start level (P1-04) and the start delay timer is active. Once the start level delay time (P1-05) expires, the iQpump drive will start. When PI output level selection (b5-09) is programmed for reverse, the alarm is displayed when the feedback level falls rises above start level (P1-04).	Wait for the start level delay time to expire. Program a different start level delay time.
Sleep Active Wait for Start	During Sleep / Wait for Start Sleep mode waiting for appropriate levels to start.	Displays when the iQpump drive is in the “sleep” mode or when the iQpump drive is waiting for feedback level to drop below start level (P1-04). When PI output level selection (b5-09) is programmed for reverse, the alarm is displayed when feedback level falls below start level (P1-04).	Wait for the sleep mode time to deactivate. Program a different start level or disable sleep mode.
Pre-Chg Mode Pre-Chg Active	During Pre-Charge The pre-charge mode is active.	Displays when “Pre-charge” mode is active.	Wait for pre-charge mode to deactivate. Disable pre-charge mode.
Pump Cycling Pump Over Cycle	Pump Over Cycle The number of cycles is exceeded.	VFD Controlled Pump exceeds number of Normal Operation to Sleep Mode Cycles. Cycle limit (P2-09) for time specified in P2-10.	Adjust sleep parameters group P2 to prevent system from cycling.
Thrust Mode Thrust Active	Thrust Bearing The thrust bearing mode is active.	Displays when “Thrust Bearing” mode is active.	Wait for thrust bearing mode to deactivate. Disable thrust bearing mode.

6.4 Operator Programming Errors (oPE)

An Operator Programming Error (oPE) occurs when an inapplicable parameter is set or an individual parameter setting is inappropriate. The iQpump drive does not operate until the parameter is set correctly. (Alarm output and fault contact do not operate.)

If an OPE occurs, change the appropriate parameter by checking the cause shown in [Table 6.4](#).

Table 6.4 OPE Error and Fault Displays

Digital Operator Display	Description	Cause	Corrective Action
oPE01 kVA Selection	Drive kVA setting error.	The control board was replaced and the kVA parameter is set incorrectly.	Enter the correct kVA setting (o2-04) by referring to the iQpump drive model number in Appendix B .
oPE02 Limit	Parameter data out of range.	Parameter set above the allowable range.	Verify the program settings.
oPE03 Terminal	Multi-function input selection fault.	Duplicate functions are selected. Speed search from maximum frequency and set frequency are set simultaneously. MOP Increase (H1-0X = 10) and MOP Decrease (H1-0X = 11) are not set simultaneously.	Verify program settings. (H1-01 ~ H1-05)
oPE05 Sequence Select	Run command is selected through serial communication at 2CN but option board is not installed.	Serial communication option board is not installed, option board is installed incorrectly. The run command selection parameter. b1-02 is set to 3 and option board is not installed.	Verify that the board is installed. Remove power to the iQpump drive and connect the option board once more.
oPE10 V/f Ptrn Setting	V/f data setting fault	V/f parameter settings are not set correctly.	Check parameters (E1-04 ~ E1-11). A minimum frequency / voltage value may be set higher than the maximum frequency / voltage.
oPE11 CarrFrq / On-Delay	Carrier frequency data setting fault. Upper limit error of C6-03.	Parameter setting incorrect.	Check the program settings and correct the errors.
Err EEPROM R/W Err	It does not match at EEPROM write.	<ul style="list-style-type: none"> Power supply is turned OFF. Parameter is reset repeatedly. 	<ul style="list-style-type: none"> Cycle power off and on to iQpump. Do a factory initialization (A1-03).

6.5 Auto-Tuning Faults

Auto-tuning faults are shown below. When the following faults are detected, the fault is displayed on the digital operator and the motor coasts to a stop during operation. The fault contact is not activated.

Table 6.5 Auto-Tuning Displays and Processing

Digital Operator Display	Probable Cause	Corrective Action
Er - 01 Fault	<ul style="list-style-type: none"> • There is an error in the data input for autotuning. • There is an error in the relationship between the motor output and the motor rated current. 	<ul style="list-style-type: none"> • Check input data. • Check iQpump and motor capacity. • Check motor rated current.
Er - 02 Minor Fault	A minor fault is detected during auto-tuning.	<ul style="list-style-type: none"> • Check input data. • Check wirings and around the machine. • Check the load.
Er - 03 STOP key	The STOP key is pressed during auto-tuning, and the auto-tuning is interrupted.	—
Er - 04 Resistance	<p>Auto-tuning is not completed within the specified time.</p> <p>The auto-tuning result became other than the parameter set range.</p>	<ul style="list-style-type: none"> • Check input data. • Check motor wiring. • If a motor and a machine are connected, disconnect the motor from the machine.
Er - 12 I-det. Circuit	<ul style="list-style-type: none"> • Current flow exceeded the motor rated current. • Current detection value symbol was reversed. • Any of U/T1, V/T2, and W/T3 has open-phase. 	<ul style="list-style-type: none"> • Check current detection circuit, wiring and mounting procedure.
Er - 13 Leakage Inductance Fault	<p>Auto-tuning did not finish within the set time.</p> <p>Tuning result was outside the acceptable parameter setting range.</p>	<ul style="list-style-type: none"> • Check motor wiring.
End - 3 Data Invalid	Rated current set value is set too high.	<ul style="list-style-type: none"> • Check input data (especially, motor output current and motor rated current value).

6.6 Digital Operator COPY Function Faults

These faults can occur occurred during the operator COPY function. Fault content is displayed on the operator. An error during the COPY function does not activate the fault contact output or alarm output.

Table 6.6 Digital Operator COPY Function Faults

Function	Digital Operator Display	Probable Causes	Corrective Action
READ Function	PrE READ IMPOSSIBLE	o3-01 was set to 1 to write a parameter when the digital operator was write-protected (o3-02 = 0).	Set o3-02 to 1 to enable writing parameters with the digital operator.
	IFe READ DATA ERROR	The read data length does not agree. The write data is incorrect.	<ul style="list-style-type: none"> Repeat the READ. Check the digital operator cable. Replace digital operator.
	rdE DATA ERROR	An attempted write of a parameter to EEPROM on the digital operator failed.	<ul style="list-style-type: none"> A low Inverter voltage has been detected. Repeat the READ. Replace digital operator.
COPY Function	CPE ID UNMATCHED	The iQpump product code or software number is different.	Use COPY function for the same product code and software number.
	VAE INV. KVA UNMATCH	The capacity of the iQpump being copied and the capacity in the digital operator are different.	Use COPY function for the same iQpump drive capacity.
	CRE CONTROL UNMATCHED	The control method of the iQpump being copied and the control method in the digital operator are different.	Use the COPY function for the same control method.
	CyE COPY ERROR	The parameter written to the iQpump was compared with the parameter in the digital operator and they were different.	COPY retest.
	CSE SUM CHECK ERROR	The checksum in the iQpump parameter area was compared with the checksum in the digital operator parameter area and they were different.	Retry the copy.
Verify Function	VyE VERIFY ERROR	The set value of the digital operator and the iQpump do not match.	Retry VERIFY function. After COPY is retested, VERIFY is retested.

6.7 Troubleshooting

Due to problems such as parameter setting errors or faulty wiring, the iQpump drive and motor may not operate as expected when the system is started up. If this occurs, use this section as a reference and apply the appropriate measures.

If a fault is displayed on the digital operator, refer to [Table 6.1](#).

◆ If the Parameter Cannot Be Set

Use the following information if an iQpump drive parameter cannot be set.

■ The display does not change when the INCREASE and DECREASE keys are pressed.

The following causes are possible.

The iQpump drive is operating (drive mode).

There are some parameters that cannot be set during operation. Remove the run command and then set the parameters.

Parameter write enable is input.

This occurs when “parameter write enable” (set value: 1B) is set for a multi-function digital input terminal (H1-01 to H1-05). If the parameter write enable input is OFF, the parameters cannot be changed. Turn it ON and then set the parameters.

Passwords do not match. (Only when a password is set.)

If the parameter A1-04 (Password) and A1-05 (Password Setting) numbers are different, the parameters for the initialize mode cannot be changed. Enter the correct password in A1-04.

If you cannot remember the password, display A1-05 (Password Setting) by pressing the Shift / Reset Key and the MENU Key simultaneously while in the A1-04 display. Reset the password and input the reset password in parameter A1-04.

■ OPE01 through OPE11 is displayed.

The set value for the parameter is wrong. Refer to 6.4 Operator Programming Errors (oPE) in this chapter and correct the setting.

■ CPF00 or CPF01 is displayed.

This is a digital operator communications error. The connection between the digital operator and the iQpump drive may be faulty. Remove the digital operator and then reinstall it.

◆ If the Motor Does Not Operate

Use the following information if the motor does not operate.

■ Ensure the digital operator is securely connected to the iQpump drive.

■ The motor does not operate when the HAND key on the Digital Operator is pressed.

The following causes are possible:

The Speed Command (Frequency Reference) is too low.

If the Speed Command (frequency reference) is set below the frequency set in E1-09 (Minimum Output Frequency), the iQpump drive will not operate.

Raise the Speed Command to at least the minimum output frequency.

■ The motor does not operate when an external run command is input.

The following causes are possible.

The iQpump drive is not in drive mode.

If the iQpump drive is not in drive mode, it will remain in ready status and will not start. Press the MENU key once and press the DATA / ENTER key. The iQpump drive is now in drive mode.

6.7 Troubleshooting

The Speed Command is too low.

If the Speed Command is set below the frequency set in E1-09 (Minimum Output Frequency), the iQpump drive will not operate. Raise the Speed Command to at least the minimum output frequency.

■ **The motor stops during acceleration or when a load is connected.**

The load may be too high. The iQpump drive has a stall prevention function and an automatic torque boost function, but the motor responsiveness limit may be exceeded if acceleration is too rapid or if the load is too great. Lengthen the acceleration time (C1-01, C1-03, or C1-05) or reduce the load. Also consider increasing the motor size.

◆ **The Direction of the Motor Rotation is Reversed**

If the motor rotates in the wrong direction, the motor output wiring is incorrect. When the iQpump drive U/T1, V/T2, and W/T3 terminals are properly connected to the motor, the motor operates in a forward direction when a forward run command is received. The forward direction depends on the manufacturer and the motor type, so be sure to check the specifications.

The direction of rotation can be reversed by switching any two wires among U/T1, V/T2, and W/T3.

◆ **If the Motor Does Not Put Out Torque or If Acceleration is Slow**

Use the following information if the motor does not output torque or if acceleration is too slow.

■ **The stall prevention level during acceleration is too low.**

If the value set for L3-02 (Stall Prevention Acceleration Level) is too low, the acceleration time will be too long. Check to be sure that the set value is suitable.

■ **The stall prevention level during running is too low.**

If the value set for L3-06 (Stall Prevention Level during Running) is too low, the motor speed and torque will be limited. Check to be sure that the set value is suitable.

◆ **If the Motor Operates at a Higher Speed than the Speed Command**

Use the following information if the motor operates at a higher speed than the Speed Command.

■ **A signal is being input to the Speed Command (current) Terminal A2.**

If a preset frequency reference is selected, the preset reference takes priority over the normal reference.

If the PI mode of operation is enabled, the iQpump drive output frequency will change to regulate the process variable to the desired setpoint. Then, the iQpump drive speed may go to maximum.

◆ **If the Motor Overheats**

Take the following steps if the motor overheats.

■ **The load is too high.**

If the motor load is too high and the motor is used when the effective torque exceeds the motor's rated torque, the motor will overheat. Reduce the load amount by either reducing the load or increasing the acceleration / deceleration times. Also consider increasing the motor size.

■ **The ambient temperature is too high.**

The motor rating is determined by a particular ambient operating temperature range. The motor will overheat if it is run continuously at the rated torque in an environment where the maximum ambient operating temperature rating is exceeded. Lower the motor's ambient temperature to within its acceptable range.

■ The withstand voltage between the motor phases is insufficient.

When the motor is connected to the iQpump drive output, voltage surges are generated by standing waves that can occur with certain combinations of iQpump drive carrier frequency and motor cable length. Normally the maximum surge voltage is three times the iQpump drive's input power supply voltage (i.e., 1200 Vac for a 480 Vac). Be sure to use a motor with a withstand voltage between the motor phases that is greater than the maximum surge voltage. In particular, when using a 480 Vac iQpump drive, use an inverter-duty (NEMA MG1, Parts 30 & 31) motor. Motor protection filter can also be an effective measure.

◆ If Peripheral Devices are Influenced by Starting or Running iQpump Drive

If noise is generated by iQpump drive switching, implement the following countermeasures:

1. Change the iQpump drive's carrier frequency selection (C6-02) to lower the carrier frequency. This will help to reduce the amount of internal switching.
2. Install an Input Noise Filter at the iQpump drive's input power terminals.
3. Use metal conduit. Electric waves can be shielded by metal, so encase the iQpump drive and power wires in metal.
4. Ground the iQpump drive and motor.
5. Separate main circuit wiring from control wiring.

◆ If a "Stand-alone" Ground Fault Interrupter Operates When the iQpump Drive is Run

The iQpump drive performs internal switching, so there is a certain amount of leakage current. This may cause an external ground fault interrupter to operate and cut off the power supply. Whenever possible, use a ground fault interrupter with a high leakage detection level (i.e., a sensitivity current of 200 mA or greater per Unit, with an operating time of 0.1 s or more), or one that incorporates high frequency countermeasures (i.e., one designed for use with drives). It will also help to change the iQpump drive's carrier frequency selection (C6-02) to lower the carrier frequency. In addition, remember that the leakage current increases as the cable is lengthened.

◆ If There is Mechanical Vibration

Use the following information when there is mechanical vibration.

■ The application is making unusual sounds.

The following causes are possible.

There may be resonance between the mechanical system's natural frequency and the carrier frequency.

This is characterized by the motor running with no noise generation, but the machinery vibrates with a high-pitched whine. To prevent this type of resonance, adjust the carrier frequency with parameter C6-02.

There may be resonance between an applications characteristic frequency and the output frequency of the iQpump drive.

To prevent this from occurring, use the jump frequency functions in parameters d3-01 to d3-04, or have the driven motor and load balanced to reduce vibration.

■ Oscillation and hunting are occurring with V/f control.

The gain adjustment may be insufficient. Reset the gain to a more effective level by raising the value of C4-02 (Torque Compensation Primary Delay Time Parameter) and then lowering the setting of n1-02 (Hunting Prevention Gain).

■ Oscillation and hunting are occurring with PI control.

If there is oscillation or hunting during PI control, check the oscillation cycle and individually adjust P and I parameters.

- Disable integral (I) control
- Reduce the proportional gain (P) until hunting stops
- Reintroduce the integral function, starting with long integral time values, to eliminate the P offset

◆ If the Motor Rotates When the iQpump Drive Output is Stopped

If the motor rotates even when the iQpump drive is stopped, the DC injection braking may be insufficient. If the motor continues operating at low speed, without completely stopping after a stop has been executed, it means that the DC injection braking is not decelerating the motor enough. Adjust the DC injection braking as follows:

6.7 Troubleshooting

- Increase the parameter b2-04 (DC Injection Braking (initial excitation) Time at Stop) setting.
- Increase the parameter b2-02 (DC Injection Braking Current) setting.

◆ If Zero Volts are Detected When a Motor is Started or Stalled

Generation of 0 V (main circuit voltage) and stalling can occur if a motor is turning when it is started and the DC injection braking is insufficient.

This can be prevented by slowing motor rotation by DC injection braking before starting. Increase parameter b2-03 (DC injection braking time at start) setting.

◆ If the Accepted Speed Command Does Not Rise to the User Speed Command Input

■ The Speed Command is within the jump frequency range.

When the jump frequency function is used, the output frequency cannot be set within the jump frequency range. Check to be sure that the Jump Frequency (parameters d3-01 to d3-03) and Jump Frequency Width (parameter d3-04) settings are suitable.

■ The frequency reference upper limit has been reached.

The output frequency upper limit is determined by the following formula:

- $\text{Freq Ref Upper Limit} = \text{Maximum Output Frequency (E1-04)} \times \text{Frequency Reference Upper Limit (d2-01)} / 100$
- Check to be sure that the parameter E1-04 and d2-01 settings are suitable.

6.8 Main Circuit Test Procedure

WARNING

Prior to removing any protective cover or wiring any part of the iQpump drive, remove all power sources, including main input power and control circuit power. Wait a minimum of 5 minutes after power removal, before removing any cover. The charge lamp located within the iQpump drive should be off prior to working inside. Even if the charge lamp is off, one must measure the AC input, output, and DC Bus potential to insure safe levels prior to resuming work. Failure to adhere to this warning may result in personal injury or death.

Before attempting any troubleshooting checks, make sure that the three-phase power is disconnected and locked out. With power removed from the unit, the DC bus capacitors will stay charged for several minutes. The Charge LED in the iQpump drive will glow red until the DC bus voltage is below 10 Vdc. To ensure that the DC bus is completely discharged, measure between the positive and negative bus with a DC voltmeter set to the highest scale.

Table 6.7 Main Circuit Test Procedures

Check	Procedure
Measure DC Bus Voltage	<ol style="list-style-type: none"> 1. Set the digital multi-meter to its highest Vdc scale. 2. Measure between ⊕ 1 and (-) for the following check: Place the positive (red) meter lead on ⊕ 1. Place the negative (black) meter lead on (-). 3. If the measured voltage is < 10 Vdc, it is safe to work inside the drive. If not, wait until the DC Bus has completely discharged.
Input Diodes (D1-D12 or Q1)	<p>The input diodes rectify or transform the three-phase input AC voltage into a DC voltage.</p> <ol style="list-style-type: none"> 1. Set a digital multi-meter to the Diode Check setting. 2. Place the positive (red) meter lead on terminal R/L1. Place the negative (black) meter lead on terminal ⊕ 1. Expected reading is about 0.5 Volts. 3. Place the positive (red) meter lead on terminal S/L2. Place the negative (black) meter lead on terminal ⊕ 1. Expected reading is about 0.5 Volts. 4. Place the positive (red) meter lead on terminal T/L3. Place the negative (black) meter lead on terminal ⊕ 1. Expected reading is about 0.5 Volts. 5. Place the positive (red) meter lead on terminal R/L1. Place the negative (black) meter lead on terminal (-). Expected reading is OL displayed. 6. Place the positive (red) meter lead on terminal S/L2. Place the negative (black) meter lead on terminal (-). Expected reading is OL displayed. 7. Place the positive (red) meter lead on terminal T/L3. Place the negative (black) meter lead on terminal (-). Expected reading is OL displayed. 8. Place the positive (red) meter lead on terminal (-). Place the negative (black) meter lead on terminal R/L1. Expected reading is about 0.5 Volts. 9. Place the positive (red) meter lead on terminal (-). Place the negative (black) meter lead on terminal S/L2. Expected reading is about 0.5 Volts. 10. Place the positive (red) meter lead on terminal (-). Place the negative (black) meter lead on terminal T/L3. Expected reading is about 0.5 Volts. 11. Place the positive (red) meter lead on terminal ⊕ 11. Place the negative (black) meter lead on terminal R/L1. Expected reading is OL displayed. 12. Place the positive (red) meter lead on terminal ⊕ 1. Place the negative (black) meter lead on terminal S/L2. Expected reading is OL displayed. 13. Place the positive (red) meter lead on terminal ⊕ 1. Place the negative (black) meter lead on terminal T/L3. Expected reading is OL displayed.

6.8 Main Circuit Test Procedure

Check	Procedure
Soft Charge Resistor Check (R1, R2, 6PCB)	<p>The soft charge resistor works in conjunction with the soft charge contactor to slowly charge the DC bus capacitors to minimize the inrush current when power is applied to the drive.</p> <ol style="list-style-type: none"> 1. Conduct a visual inspection. Check for physical damage. 2. Set a digital multi-meter to the R x 1 scale. 3. If the resistor is damaged, the measured value will be infinite ohms.
Soft Charge Contactor (K1)	<p>The purpose of the soft charge contactor is to bypass the soft charge resistor after the DC bus voltage has reached its normal operating level.</p> <ol style="list-style-type: none"> 1. Conduct a visual inspection. Check for physical damage. 2. Set a digital multi-meter to the R x 1 scale. 3. On drives with a board-mounted contactor, verify that each contact resistance measures infinite ohms. 4. On drives without a board-mounted contactor, press the plunger in, and verify that each contact measures 0 ohms. 5. On drives without a board-mounted contactor, release the plunger, and verify that the resistance is the ohmic value of the soft charge resistor. 6. On drives with a board-mounted contactor, verify that the contactor coil measures about 300 ohms. The coil can be tested by applying the appropriate voltage to verify the contacts change states. 7. On drives without a board-mounted contactor, verify that the 230 Vac contactor coil measures about 175 ohms. The coil can be tested by applying the appropriate voltage to verify the contacts change states. 8. On drives without a board-mounted contactor, verify that the 24 Vdc auxiliary coil measures about 2.2 M ohms. The coil can be tested by applying the appropriate voltage to verify the contacts change states.
DC Bus Fuse (F1)	<p>The DC bus fuse is located in the negative portion of the DC Bus. The DC bus fuse is used to protect the main circuit components if the output transistors short. If the DC bus fuse is open, at least one of the output transistors has failed. When a transistor fails, there is a short between the positive and negative portions of the DC Bus. The DC bus fuse does not protect the transistors, but protects the rest of the main circuit from the high current present during a short. <i>Never replace the DC bus fuse without first checking all of the output transistors.</i></p> <ol style="list-style-type: none"> 1. Set a digital multi-meter to the R x 1 scale. 2. Place one lead of the multi-meter on one side of the fuse and place the other lead of the multi-meter on the other side of the fuse. 3. If the fuse is good, the measured value will be 0 ohms. 4. If the fuse is bad, the measured value will be infinite ohms.
Output Transistors (Q1-Q12)	<p>The output transistors are used to switch the DC bus voltage to allow current to flow to the motor.</p> <ol style="list-style-type: none"> 1. Set a digital multi-meter to the Diode Check setting. 2. Place the positive (red) meter lead on terminal U/T1. Place the negative (black) meter lead on terminal ⊕ 1. Expected reading is about 0.5 Volts. 3. Place the positive (red) meter lead on terminal V/T2. Place the negative (black) meter lead on terminal ⊕ 1. Expected reading is about 0.5 Volts. 4. Place the positive (red) meter lead on terminal W/T3. Place the negative (black) meter lead on terminal ⊕ 1. Expected reading is about 0.5 Volts. 5. Place the positive (red) meter lead on terminal U/T1. Place the negative (black) meter lead on terminal (-). Expected reading is OL displayed. 6. Place the positive (red) meter lead on terminal V/T2. Place the negative (black) meter lead on terminal (-). Expected reading is OL displayed. 7. Place the positive (red) meter lead on terminal W/T3. Place the negative (black) meter lead on terminal (-). Expected reading is OL displayed. 8. Place the positive (red) meter lead on terminal (-). Place the negative (black) meter lead on terminal U/T1. Expected reading is about 0.5 Volts. 9. Place the positive (red) meter lead on terminal (-). Place the negative (black) meter lead on terminal V/T2. Expected reading is about 0.5 Volts. 10. Place the positive (red) meter lead on terminal (-). Place the negative (black) meter lead on terminal W/T3. Expected reading is about 0.5 Volts.

Check	Procedure
Output Transistors (Q1-Q12) (Continued)	<ol style="list-style-type: none"> 11. Place the positive (red) meter lead on terminal $\oplus 1$. Place the negative (black) meter lead on terminal U/T1. Expected reading is OL displayed. 12. Place the positive (red) meter lead on terminal $\oplus 1$. Place the negative (black) meter lead on terminal V/T2. Expected reading is OL displayed. 13. Place the positive (red) meter lead on terminal $\oplus 1$. Place the negative (black) meter lead on terminal W/T3. Expected reading is OL displayed.
Control Power Fuse	<p>All drives have a Control Power Fuse. The fuse is located on either the Power PCB (3PCB) or the Gate Drive PCB (3PCB). The Control Power Fuse protects the primary switching mode power supply.</p> <ol style="list-style-type: none"> 1. Set a digital multi-meter to the R x 1 scale. 2. Place one lead of the multi-meter on one side of the fuse and place the other lead of the multi-meter on the other side of the fuse. 3. If the fuse is good, the measured value will be 0 ohms. If the fuse is bad, the measured value will be infinite ohms.
24 Vdc Cooling Fans (Heat Sink & Internal)	<p>The Heat Sink & Internal Cooling Fans cool the heat sink as well as the output transistor modules of the drive.</p> <ol style="list-style-type: none"> 1. Conduct a visual inspection to ensure the fan turns freely. 2. If there is no physical evidence that the fan is bad, the fan motor can be checked with a digital multi-meter. 3. Set the digital multi-meter to the R x 1 scale. 4. Measure across the fan motor terminals. If 0 ohms are measured, conclude that the fan motor is shorted. If infinite ohms are measured, conclude that the fan motor is burned open. 5. If the fan is not working, then disconnect the fan and apply 24 Vdc to the fan to test the motor.
230 / 240 Vac Cooling Fans (Heat Sink)	<p>The Heat Sink Cooling Fans cool the heat sink to remove heat from the drive.</p> <ol style="list-style-type: none"> 1. Conduct a visual inspection to ensure the fan turns freely. 2. If there is no physical evidence that the fan is bad, the motor can be checked with a digital multi-meter. 3. Set a digital multi-meter to the R x 1 scale. 4. Measure across the fan motor terminals. If the fan motor is good, the measured value should be about 500 ohms. If 0 ohms are measured, conclude that the fan motor is shorted. If infinite ohms are measured, conclude that the fan motor is burned open. 5. If the fan is not working, then disconnect the fan and apply 230 / 240 Vac to the fan to test the motor.
Cooling Fan Fuse	<p>Large drive units contain a Cooling Fan Fuse. It is located on either the Gate Drive Board (3PCB) or the Tap Change Board (8PCB). If the Cooling Fan Fuse is open, then the 230 / 240 Vac cooling fans may be defective.</p> <ol style="list-style-type: none"> 1. Set a digital multi-meter to the R x 1 scale. 2. Place one lead of the multi-meter on one side of the fuse and place the other lead of the multi-meter on the other side of the fuse. 3. If the fuse is good, the measured value will be 0 ohms. If the fuse is bad, the measured value will be infinite ohms.

6.9 Drive Date Stamp Information

This information is used to determine when a iQpump drive was built to see if it is within its warranty period. The date stamp is located on the lower right side of the iQpump drive.

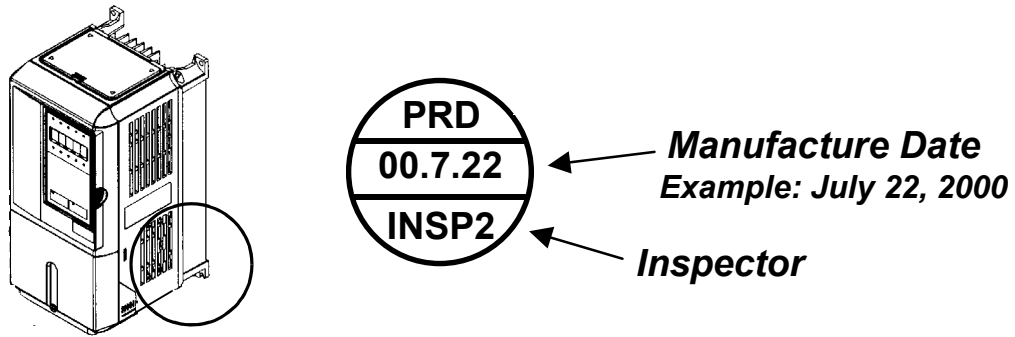

Figure 6.1 Date Stamp Location



Maintenance

This chapter describes basic maintenance and inspection of the iQpump drive. Please refer to these instructions to ensure that the iQpump drive receives the proper maintenance to maintain overall performance.

7.1 Periodic Inspection	160
7.2 Preventive Maintenance	161
7.3 Heatsink Cooling Fan Replacement	162
7.4 Removing and Mounting the Terminal Card	164

7.1 Periodic Inspection

Check the following items during periodic maintenance.

- The motor should not be vibrating or making unusual noises.
- There should be no abnormal heat generation from the iQpump drive or motor.
- The ambient temperature should be within the iQpump drive specification of -10 °C to 40 °C (14 °F to 104 °F).
- The output current value shown in parameter U1-03 should not be higher than the motor rated current for an extended period of time.
- The cooling fan in the iQpump drive should be operating normally.

Always turn OFF the input power before beginning inspection. Confirm that the digital operator indicators on the front cover have all turned OFF, and then wait an additional five minutes before beginning the inspection. Be sure not to touch terminals immediately after the power has been turned off. Doing so can result in electric shock. *Refer to Warnings and Cautions on page 13.*

WARNING

Prior to removing any protective cover or wiring any part of the iQpump drive, remove all power sources, including main input power and control circuit power. Wait a minimum of 5 minutes after power removal, before removing any cover. The charge lamp located within the iQpump drive should be off prior to working inside. Even if the charge lamp is off, one must measure the AC input, output, and DC Bus potential to insure safe levels prior to resuming work. Failure to adhere to this warning may result in personal injury or death.

Table 7.1 Periodic Inspections With No Power Applied

Item	Inspection	Corrective Action
External terminals, mounting bolts, connectors, etc.	Are all screws and bolts tight?	Tighten loose screws and bolts firmly.
	Are connectors tight?	Reconnect the loose connectors.
Cooling fins	Are the fins dirty or dusty?	Clean off any dirt and dust with an air gun using clean and dry air at a pressure between 55-85 psi.
Control PCB Terminal PCB Power PCB Gate Drive PCBs	Is there any conductive dirt or oil mist on the PCBs?	Clean off any dirt and dust with an air gun using clean and dry air at a pressure between 55-85 psi. Replace the boards if they cannot be made clean.
Input Diodes IPMs Output Transistors	Is there any conductive dirt or oil mist on the modules or components?	Clean off any dirt and dust with an air gun using clean and dry air at a pressure between 55-85 psi.
DC bus capacitors	Are there any irregularities, such as discoloration or odor?	Replace the capacitors or iQpump drive.

Apply power to the iQpump drive and conduct the following inspection.

Table 7.2 Periodic Inspections With Power Applied

Item	Inspection	Corrective Action
Cooling fan(s)	Is there any abnormal noise or vibration, or has the total operating time exceeded 20,000 hours. Check U1-40 for elapsed cooling fan operation time.	Replace Cooling Fan

7.2 Preventive Maintenance

Table 7.3 Preventive Maintenance

Inspection Points	Item	Check Points	Every 3-6 Months	Yearly
General	Environment	Ambient Temperature	X	
		Humidity	X	
		Dust	X	
Harmful Gas		X		
Oil Mist		X		
	Equipment	Abnormal vibration or noise	X	
	AC Power Supply	Main circuit & control voltage	X	
AC Power Circuit & Devices	Conductors & Wire Connections	Loose lugs, screws & wires		X
		Hot spots on parts		X
		Corrosion		X
		Bent conductors		X
		Breakage, cracking or discoloration		X
	Check spacing		X	
	Transformers & Reactors	Discoloration or Noise	X	
Terminal Blocks	Loose, damaged		X	
DC Bus Capacitors		Leakage		X
		Ruptures, broken, expansion		X
		Capacitance & insulation resistance		X
Relays & Contactors		Noisy		X
		Contact discoloration		X
Soft Charge Resistors		Cracked		X
		Discoloration		X
Control Circuits	Operation	Speed reference voltage / current		X
		I/O contact operation		X
Cooling System	Cooling Fans / Fins & Heatsink	Abnormal fan noise	X	
		Loose connectors		X
		Free of accumulation	X	
Keypad / Display	Digital Operator	LEDs	X	
		Monitor display values	X	
		Key functionality		X
		Clean		X

If the iQpump drive is used under the following conditions, it may be necessary to inspect more often:

- High ambient temperatures, humidity or altitudes above 3,300 feet
- Frequent starting and stopping
- Fluctuations of the AC power supply or load
- Excessive vibration and / or shock loading
- Poor environment, including dust, metal particles, salt, sulfuric acid, chlorine

7.3 Heatsink Cooling Fan Replacement

◆ Models CIMR-P7U20P4 thru 2018 (25 HP @ 208 V / 240 V) and 40P4 thru 4018 (30 HP @ 480 V)

A cooling fan is attached to the bottom of the iQpump drive.

If the iQpump drive is installed using the mounting holes on the back of the iQpump drive heatsink, the cooling fan can be replaced without removing the iQpump drive from the enclosure panel.

If the iQpump drive is mounted with the heatsink external to the enclosure, the cooling fan can only be replaced by removing the iQpump drive from the enclosure.

■ Removing the Heatsink Cooling Fan

1. Always turn OFF the input power before removing and installing the heatsink cooling fan.
2. Press in on the right and left sides of the fan cover in the direction of arrows “1” and then pull the fan out in the direction of arrow “2.”
3. Pull out the cable connected to the fan from the fan cover and disconnect the power connector. See [Figure 7.1](#).
4. Open the fan cover on the left and right sides in the direction of arrows “3” and remove the fan cover from the fan.

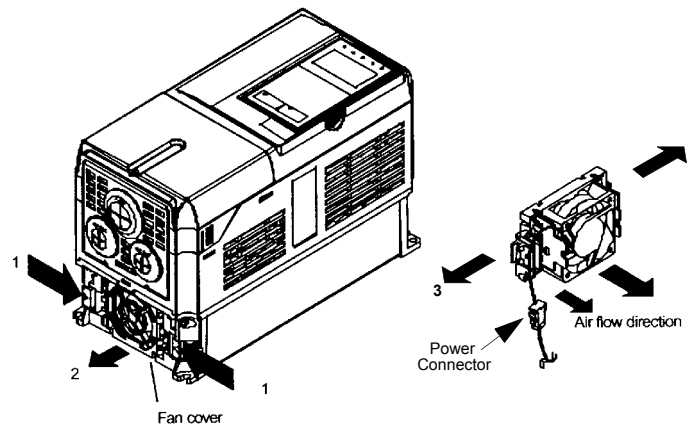

Figure 7.1 Cooling Fan Replacement Procedure

■ Installing the Heatsink Cooling Fan

1. Attach the fan cover to the cooling fan. Be sure that the air flow direction indicated by the arrows above faces into the iQpump drive.
2. Connect the power connector securely and place the power connector and cable into the fan cover.
3. Mount the fan cover on the iQpump drive. Be sure that the tabs on the sides of the fan cover click into place on the iQpump drive.

◆ Models CIMR-P7U2022 thru 2110 (30 HP to 150 HP @ 208 V / 240 V) and 4024 thru 4300 (40 HP to 500 HP @ 480 V)

A cooling fan assembly is attached to the top inside the iQpump drive. The cooling fan assembly includes the heat sink cooling fans and the internal cooling fan. The cooling fan(s) can be replaced without removing the iQpump drive from the enclosure panel.

■ Removing the Cooling Fan Assembly

1. Always turn OFF the input power before removing and installing the heatsink cooling fan assembly.
2. Remove the terminal cover, iQpump drive cover, Digital Operator, and front cover from the front of the iQpump drive.
3. Remove the Control PCB bracket (if necessary) to which the cards are mounted. Remove all cables connected to the Control PCB and remove the cooling fan power connector from the fan board (13 PCB) positioned near the top of the iQpump drive.
4. Remove the cooling fan power connectors from the gate drive board (3 PCB) positioned at the back of the iQpump drive.
5. Remove the fan assembly screws and pull out the fan assembly from the iQpump drive.
6. Remove the cooling fan(s) from the fan assembly.

■ Mounting the Cooling Fan Assembly

After attaching a new cooling fan, reverse the above procedure to attach all of the components.

When attaching the cooling fan to the mounting bracket, be sure that the air flow goes toward the top of the iQpump drive.

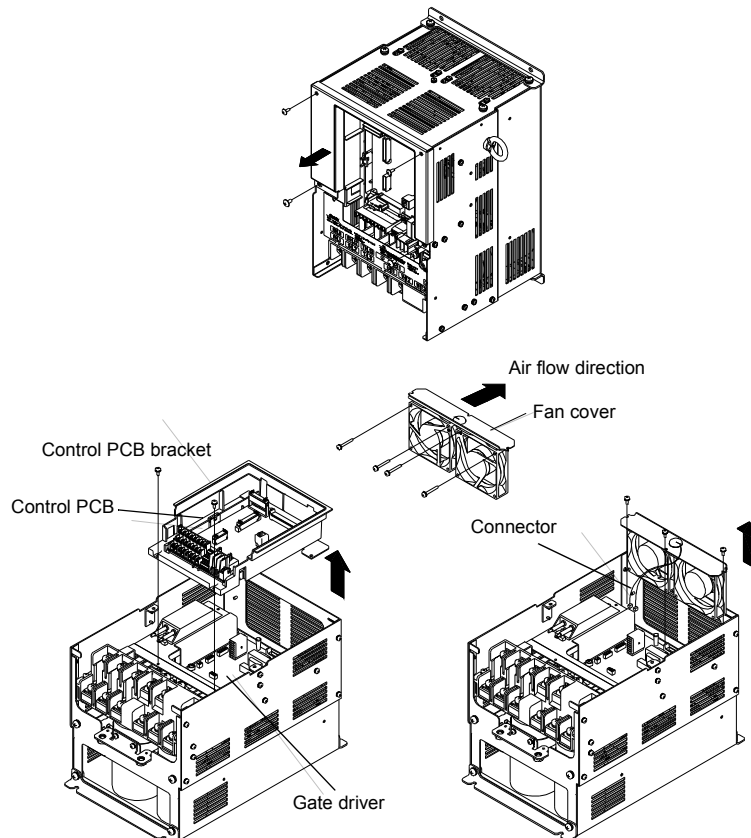

Figure 7.2 Cooling Fan Assembly Replacement Procedure

7.4 Removing and Mounting the Terminal Card

The terminal card can be removed and mounted without disconnecting the control wiring.

Note: Always confirm that input power is removed and the Charge LED is not lit before removing or mounting the terminal card.

◆ Removing the Terminal Card

1. Remove the terminal cover on the iQpump drive.
2. Remove the digital operator and front cover on the iQpump drive.
3. Remove the wires connected to FE and NC on the terminal card.
4. Loosen the mounting screws on the left and right sides of the terminal card until they are free. It is not necessary to remove the mounting screws completely since they are captive and self-rising.
5. Pull the terminal card out in the direction of the block arrow.

◆ Mounting the Terminal Card

Reverse the removal procedure to mount the terminal card.

Confirm that the terminal card and the Control PCB properly meet at connector CN8 before insertion.

The connector pins may be bent if the terminal card is forced into place, possibly preventing correct iQpump drive operation.

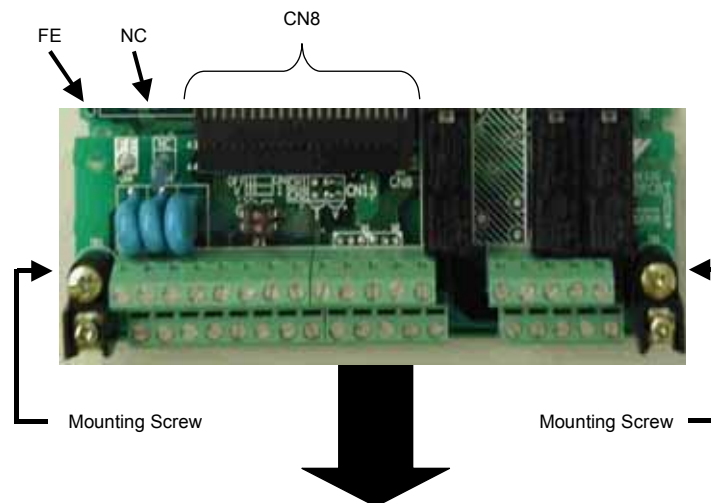

Figure 7.3 Terminal Card Removal Procedure



Appendix: A

Parameters

This appendix lists all the parameter numbers and names, along with a description of each. Also, below the parameter name in bold type is the abbreviated name as it appears on the digital operator display / keypad.

PARAMETER LIST	166
MONITOR LIST	197

Parameter List

Table 1 Parameter List

Parameter No.	Addr. Hex	Parameter Name Digital Operator Display	Description	Setting Range	Factory Setting	Menu Location	Page No.
Initialization							
A1-00 ◆	0100	Language Selection Select Language	Language selection for digital operator display. 0: English 2: Deutsch 3: Francais 4: Italiano 5: Espanol 6: Portugues *Not returned to factory setting by initialization	0 ~ 6	0	Programming	—
A1-01 ◆	0101	Access Level Selection Access Level	This setting determines which parameters are accessible. 0: Operation Only 2: Advanced Level	0 or 2	2	Programming	90
A1-03	0103	Initialize Parameters Init Parameters	Used to return all parameters to their factory or user setting. 0: No Initialize 1110: User Initialize (The user must set their own parameter default values and then parameter o2-03 must be set to "1" to save them. If the parameter values are changed after o2-03 is set to "1", the user default values can be restored by setting A1-03 to 1110.) 2220: 2-Wire Initial 3330: 3-Wire Initial	0 ~ 3330	0	Programming	90
A1-04	0104	Password 1 Enter Password	When the value set into A1-04 does NOT match the value set into A1-05, parameters A1-01 thru A1-03 cannot be changed. All other parameters as determined by A1-01 can be changed. Parameter A1-05 can be accessed by pressing the MENU key while holding the RESET key.	0 ~ 9999	0	Programming	—
A1-05	0105	Password 2 Select Password		0 ~ 9999	0	Programming	—
◆ Denotes that parameter can be changed when the drive is running. * Menu location is Pump Quick Setup when b5-01=1, and Programming when b5-01=0.							
Sequence							
b1-01	0180	Frequency Reference Selection Reference Source	Selects the speed command (frequency reference) input source. 0: Operator - Digital preset speed d1-01 1: Terminals - Analog Input Terminal A1 (or Terminal A2 see parameter H3-13) 2: Serial Com - RS-485 Terminals R+, R-, S+ and S- 3: Option PCB - Option board connected at 2CN	0 ~ 3	0	Programming	91
b1-02	0181	Run Command Selection Run Source	Selects the run command input source. 0: Operator - "Hand" and "Off" keys on digital operator 1: Terminals - Contact Closure on Terminal S1 2: Serial Com - RS-485 Terminals R+, R-, S+ and S- 3: Option PCB - Option board connected at 2CN 5: Timed Run <0034>	0 ~ 3, 5	0	Programming	94
b1-03	0182	Stopping Method Selection Stopping Method	Selects the stopping method when the run command is removed. 0: Ramp to Stop 1: Coast to Stop 2: DC Injection to Stop 3: Coast w / Timer (A new run command is ignored if input before the time in C1-02 expires.)	0 ~ 3	0	Programming	96
b1-07	0186	Local / Remote Run Selection LOC/REM RUN Sel	0: Cycle External RUN - If the run command is closed when switching from hand (local) mode to auto (remote) mode, the drive will not run. 1: Accept External RUN - If the run command is closed when switching from hand (local) mode to auto (remote) mode, the drive WILL run. Note: Used with LCD Operator only.	0 ~ 1	0	Programming	—
b1-08	0187	Run Command Selection During Program RUN CMD at PRG	0: Disabled - Run command accepted only in the operation menu. 1: Enabled - Run command accepted in all menus (except when b1-02 = 0).	0 ~ 1	0	Programming	—
b1-11	010F	Drive Delay Time Setting Wait to Run Time	After a run command, drive output will start after this delay time.	0 ~ 600 s	0 s	Programming	—
DC Braking							
b2-01	0189	DC Injection Braking Start Frequency DCInj Start Freq	Sets the frequency at which DC injection braking starts when ramp to stop (b1-03 = 0) is selected. If b2-01 < E1-09, DC injection braking starts at E1-09.	0.0 ~ 10.0 Hz	0.5 Hz	Programming	98

Parameter No.	Addr. Hex	Parameter Name Digital Operator Display	Description	Setting Range	Factory Setting	Menu Location	Page No.
b2-02	018A	DC Injection Braking Current DCInj Current	Selects the DC injection braking current as a percentage of the drive rated current.	0 ~ 100 %	50 %	Programming	99
b2-03	018B	DC Injection Braking Time at Start DCInj Time @ Start	Sets the time length of DC injection braking at start in units of 1 second.	0.00 to 10.00 s	0.00 s	Programming	99
b2-04	018C	DC Injection Braking Time at Stop DCInj Time @ Stop	When b1-03 = 2 actual DC Injection time is calculated as follows: b2-04 x 10 x Output Frequency / E1-04. When b1-03 = 0, this parameter determines the amount of time DC Injection is applied to the motor at the end of the decel ramp. This should be set to a minimum of 0.50 seconds when using HSB. This will activate DC injection during the final portion of HSB and help ensure that the motor stops completely.	0.00 ~ 10.00 s	0.5 s	Programming	99
b2-09	01E1	Motor Pre-Heat Current Preheat Current	Motor Pre-heat current in % of drive rated current. This is used to keep the motor warm to prevent condensation and is used in conjunction with a digital input (data = 60).	0 ~ 100 %	0 %	Programming	99
Speed Search							
b3-01	0191	Speed Search Selection SpdSrch at Start	Enables / disables and selects the speed search function at start. 0: SpdsrchF Disable - Speed search at start is disabled (estimated speed method is used at other times) 1: SpdsrchF Enable - Speed search is enabled (estimated speed method) 2: SpdsrchI Disable - Speed search at start is disabled (current detection method is used at other times) 3: SpdsrchI Enable - Speed search is enabled (current detection method) Estimated Speed Method: Actual motor speed and direction is estimated, then the motor is ramped from that speed to the commanded speed. Current Detection Method: Current level is monitored while output frequency is ramped down.	0 ~ 3	2	Programming	—
b3-02	0192	Speed Search Deactivation Current SpdSrch Current	Used only when b3-01 = 3. Sets the speed search operation current as a percentage of drive rated current.	0 ~ 200 %	120 %	Programming	—
b3-03	0193	Speed Search Deceleration Time SpdSrch Dec Time	Used only when b3-01 = 3. Sets the deceleration time during speed search.	0.1 ~ 10.0 s	2.0 s	Programming	—
b3-05	0195	Speed Search Delay Time Search Delay	Delays the speed search operation after a momentary power loss to allow time for an external output contactor to re-energize.	0.0 ~ 20.0 s	0.2 s	Programming	—
b3-14	019E	Bidirectional Speed Search Selection Bidir Search Sel	0: Disabled 1: Enabled	0 ~ 1	1	Programming	—
Delay Timers							
b4-01	01A3	Timer Function ON-Delay Time Delay-ON Timer	Used in conjunction with a multi-function digital input and a multi-function digital output. This sets the amount of time between when the digital input is closed, and the digital output is energized.	0.0 ~ 3000.0 s	0.0 s	Programming	—
b4-02	01A4	Timer Function OFF-Delay Time Delay-OFF Timer	Used in conjunction with a multi-function digital input and a multi-function digital output. This sets the amount of time the output stays energized after the digital input is opened.	0.0 ~ 3000.0 s	0.0 s	Programming	—
PI Control							
b5-01	01A5	PI Mode Setting PI Mode	This parameter enable / disables the closed loop (PI) controller. 0: Disabled 1: Enabled (commanded speed becomes PI setpoint) 2: Enabled - 2 Zone (dual zone PI enabled) <0034>	0 ~ 2	1	Programming	100
b5-02 ◆	01A6	Proportional Gain Setting P Gain	Sets the proportional gain of the PI controller.	0.00 ~ 25.00	2.00	Programming	100
b5-03 ◆	01A7	Integral Time Setting PI I Time	Sets the integral time for the PI controller. A setting of zero disables integral control.	0.0 ~ 360.0 s	3.0 s	Programming	100
b5-04 ◆	01A8	Integral Limit Setting PI I Limit	Sets the maximum output possible from the integrator. Set as a % of fmax.	0.0 ~ 100.0 %	100.0 %	Programming	100
b5-06 ◆	01AA	PI Output Limit PI Limit	Sets the maximum output possible from the entire PI controller. Set as a % of fmax.	0.00 ~ 100.00 %	100.00 %	Programming	102
◆ Denotes that parameter can be changed when the drive is running.							

Parameter No.	Addr. Hex	Parameter Name Digital Operator Display	Description	Setting Range	Factory Setting	Menu Location	Page No.
b5-07 ◆	01AB	PI Offset Adjustment PI Offset	Sets the amount of offset of the output of the PI controller. Set as a % of fmax. The PI Offset Adjustment parameter has two different uses. Parameter b5-07 serves different functions depending on whether it is used on a standard PI loop or a Differential PI loop. 1: Parameter b5-07 causes an offset to be applied to the output of the PI function in a non-Differential PI loop. Every time the PI output is updated, the offset is summed with the PI output. This can be used to artificially kick-start a slow starting PI loop. 2: If the drive is configured for Differential PI Regulation (H3-09 = 16), then the PI Offset is the targeted maintained differential between the signal measured on analog input A1 and the signal measured on analog input A2.	-100.0 ~ +100.0 %	0.0 %	Programming	102
b5-08 ◆	01AC	PI Primary Delay Time Constant PI Delay Time	Sets the amount of time for a filter on the output of the PI controller.	0.00 ~ 10.00 s	0.00 s	Programming	103
b5-09	01AD	PI Output Level Selection Output Level Sel	Determines whether the PI controller will be direct or reverse acting. 0: Normal Output (direct acting) 1: Reverse Output (reverse acting)	0 ~ 1	0	Programming	103
b5-10	01AE	PI Output Gain Setting Output Gain	Sets the output gain of the PI controller.	0.0 ~ 25.0	1.0	Programming	103
b5-12	01B0	PI Feedback Reference Missing Detection Selection Fb los Det Sel	0: Disabled 1: Alarm 2: Fault	0 ~ 2	2	Programming	103
b5-13	01B1	PI Feedback Loss Detection Level Fb los Det Lvl	Sets the PI feedback loss detection level as a percentage of maximum frequency (E1-04).	0 ~ 100 %	0 %	Programming	103
b5-14	01B2	PI Feedback Loss Detection Time Fb los Det Time	Sets the PI feedback loss detection delay time in terms of seconds.	0.0 ~ 25.5 s	2.0 s	Programming	103
b5-17	01B5	PI Accel / Decel Time Acc/Dec Time	Applies an accel / decel time to the PI setpoint reference.	0.0 ~ 25.5 s	0.0 s	Programming	104
b5-32	85F	Integrator Ramp Limit Int Ramp Lim	When set a value greater than zero, the PI Integrator is forced to be within + / - this amount of the soft starter output	0.0 ~ 10.0 Hz	0.0 Hz	Programming	
◆ Denotes that parameter can be changed when the drive is running.							
Energy Saving							
b8-01	01CC	Energy Saving Control Selection Energy Save Sel	Energy Savings function enable / disable selection 0: Disabled 1: Enabled	0 ~ 1	0	Programming	104
b8-04	01CF	Energy Saving Coefficient Value Energy Save COEF	Used to fine-tune the energy savings function.	0.0 ~ 655.0	kVA Dependent	Programming	104
b8-05	01D0	Power Detection Filter Time kW Filter Time		0 ~ 2000 ms	20 ms	Programming	104
b8-06	01D1	Search Operation Voltage Limit Search V Limit		0 ~ 100 %	0 %	Programming	104
Accel/Decel							
C1-01 ◆	0200	Acceleration Time 1 Accel Time 1	Sets the time to accelerate from zero to maximum frequency.	0.0 ~ 6000.0 s	20.0 s	Programming	105
C1-02 ◆	0201	Deceleration Time 1 Decel Time 1	Sets the time to decelerate from maximum frequency to zero.		10.0 s	Programming	105
C1-03 ◆	0202	Acceleration Time 2 Accel Time 2	Sets the time to accelerate from zero to maximum frequency when selected via a multi-function input.		10.0 s	Programming	105
C1-04 ◆	0203	Deceleration Time 2 Decel Time 2	Sets the time to decelerate from maximum frequency to zero when selected via a multi-function input.		10.0 s	Programming	105
C1-05 ◆	0204	Acceleration Time 3 Accel Time 3	Sets the time to accelerate from zero to maximum frequency when activated by P3-12. Used for system response stabilization.		50.0 s	Programming	105
C1-06 ◆	0205	Deceleration Time 3 Decel Time 3	Sets the time to decelerate from maximum frequency to zero when activated by P3-12. Used for system response stabilization.		50.0 s	Programming	105
◆ Denotes that parameter can be changed when the drive is running.							

Parameter No.	Addr. Hex	Parameter Name Digital Operator Display	Description	Setting Range	Factory Setting	Menu Location	Page No.
C1-09	0208	Fast Stop Time Fast Stop Time	Sets the time to decelerate from maximum frequency to zero for the "Fast Stop" function.	0.0 ~ 6000.0 s	10.0 s	Programming	—
C1-11	020A	Accel / Decel Switch Frequency Acc/Dec SW Freq	Sets the frequency for automatic switching of accel / decel times. Fout < C1-11: Accel / Decel Time 2 Fout > = C1-11: Accel / Decel Time 1 Multi-function input "Multi-Acc / Dec 1" has priority over C1-11.	0.0 ~ 200.0 Hz	0.0 Hz	Programming	—
S-Curve Accel/Decel							
C2-01	020B	S-Curve Characteristic at Accel Start SCrv Acc @ Start	<p>S-curve is used to further soften the starting ramp. The longer the S-curve time, the softer the starting ramp.</p>	0.00 ~ 2.50 s	0.20 s	Programming	—
C2-02	020C	S-Curve Characteristic at Accel End SCrv Acc @ End		0.00 ~ 2.50 s	0.20 s	Programming	—
Torque Compensation							
C4-01 ◆	0215	Torque Compensation Gain Torq Comp Gain	This parameter helps to produce better starting torque. It determines the amount of torque or voltage boost based upon motor current and motor resistance.	0.00 ~ 2.50	1.00	Programming	—
C4-02	0216	Torque Compensation Primary Delay Time Torq Comp Time	This parameter adjusts a filter on the output of the torque compensation function. Increase to add torque stability, decrease to improve torque response.	0 ~ 10000 ms	200 ms	Programming	—
◆ Denotes that parameter can be changed when the drive is running.							
Carrier Frequency							
C6-02	0224	Carrier Frequency Selection CarrierFreq Sel	Carrier frequency sets the number of pulses per second of the output voltage waveform. 1: 2.0 kHz 2: 5.1 kHz 3: 8.0 or 7.0* kHz F: Program (Determined by the setting of C6-03) * when an option card is installed	1 ~ F	kVA Dependent	Programming	—
C6-03	0225	Carrier Frequency Upper Limit CarrierFreq Max	Maximum carrier frequency allowed when C6-02 = F.	0.4 ~ 15.0 kHz	kVA Dependent	Programming	—

Parameter No.	Addr. Hex	Parameter Name Digital Operator Display	Description	Setting Range	Factory Setting	Menu Location	Page No.
Preset Reference							
d1-01 ◆	0280	Set-point Reference 1 Set-point 1	Digital preset setpoint reference 1. Used when b1-01 = 0 and when in "hand" mode. Setting units are affected by P1-02.	1 ~ P1-03 Value 0.00 to P1-02 Value <0034>	0.00	Programming	—
d1-02 ◆	0281	Set-point Reference 2 Set-point 2	Digital preset setpoint reference 2. Selected via multi-function input terminals. Setting units are affected by P1-02. Parameter d1-02 is also the Zone 1 PI reference when b5-01 = 2. <0034>		0.00	Programming	—
d1-03 ◆	0282	Set-point Reference 3 Set-point 3	Digital preset setpoint reference 3. Selected via multi-function input terminals. Setting units are affected by P1-02. Parameter d1-03 is also the Zone 2 PI reference when b5-01 = 2. <0034>		0.00	Programming	—
d1-04 ◆	0283	Set-point Reference 4 Set-point 4	Digital preset setpoint reference 4. Selected via multi-function input terminals. Setting units are affected by P1-02. Parameter d1-04 is also the Zone 1 and 2 PI reference when b5-01 = 2. <0034>		0.00	Programming	—
d1-17 ◆	0292	Jog Frequency Reference Jog Reference	Jog reference used when a jog is selected via the LCD operator keypad. This parameter is not available with the HOA operator. Setting units are affected by o1-03.		0.00	Programming	—
◆ Denotes that parameter can be changed when the drive is running.							
Reference Limits							
d2-01	0289	Frequency Reference Upper Limit Ref Upper Limit	Determines maximum speed command, set as a percentage of parameter E1-04. If speed command is above this value, actual drive speed will be limited to this value. This parameter applies to all speed command sources.	0.0 ~ 110.0 %	100.0 %	Programming	105
d2-02	028A	Frequency Reference Lower Limit Ref Lower Limit	Determines minimum speed command, set as a percentage of parameter E1-04. If speed command is below this value, actual drive speed will be set to this value. This parameter applies to all speed command sources.	0.0 ~ 110.0 %	0.0 %	Programming	105
d2-03	0293	Master Speed Reference Lower Limit Ref1 Lower Limit	Determines the minimum speed command, set as a percentage of parameter E1-04. If speed command is below this value, actual drive speed will be set to this value. This parameter only applies to analog inputs A1 and A2.	0.0 ~ 110.0 %	0.0 %	Programming	106
Jump Frequencies							
d3-01	0294	Jump Frequency 1 Jump Freq 1	These parameters allow programming of up to three prohibited frequency points for eliminating problems with resonant vibration of the motor / machine. This feature does not actually eliminate the selected frequency values, but will accelerate and decelerate the motor through the prohibited bandwidth.	0.0 ~ 200.0 Hz	0.0 Hz	Programming	106
d3-02	0295	Jump Frequency 2 Jump Freq 2			0.0 Hz	Programming	106
d3-03	0296	Jump Frequency 3 Jump Freq 3			0.0 Hz	Programming	106
d3-04	0297	Jump Frequency Width Jump Bandwidth	This parameter determines the width of the deadband around each selected prohibited frequency point. A setting of "1.0" will result in a deadband of + / - 1.0 Hz.	0.0 ~ 20.0 Hz	1.0 Hz	Programming	106
V/f Pattern							
E1-01	0300	Input Voltage Setting Input Voltage	Set to the nominal voltage of the incoming line.	155 ~ 255.0 (240V) 310 to 510.0 (480V)	240 V 480 V	Programming	107
E1-03	0302	V/f Pattern Selection V/f Selection	0: 50 Hz 1: 60 Hz Saturation 2: 50 Hz Saturation 3: 72 Hz 4: 50 Hz VT1 5: 50 Hz VT2 6: 60 Hz VT1 7: 60 Hz VT2 8: 50 Hz HST1 9: 50 Hz HST2 A: 60 Hz HST1 B: 60 Hz HST2 C: 90 Hz D: 120 Hz F: Custom V/F FF: Custom w/o limit	0 ~ FF	F	Programming	107

Parameter No.	Addr. Hex	Parameter Name Digital Operator Display	Description	Setting Range	Factory Setting	Menu Location	Page No.	
E1-04	0303	Maximum Output Frequency Max Frequency	<p>Output voltage (V)</p> <p>To set V/f characteristics in a straight line, set the same values for E1-07 and E1-09. In this case, the setting for E1-08 will be disregarded. Always ensure that the four frequencies are set in the following manner: E1-04 (FMAX) \geq E1-06 (FA) $>$ E1-07 (FB) \geq E1-09 (FMIN)</p>	0.0 ~ 120.0 Hz	60.0 Hz	Programming	108	
E1-05	0304	Maximum Output Voltage Max Voltage		0.0 ~ 255.0 (240V) 0.0 to 510.0 (480V)	230.0 V 460.0 V	Programming	108	
E1-06	0305	Base Frequency Base Frequency		0.0 ~ 200.0 Hz	60.0 Hz	Programming	109	
E1-07	0306	Mid Output Frequency A Mid Frequency A		0.0 ~ 200.0 Hz	3.0 Hz	Programming	109	
E1-08	0307	Mid Output Voltage A Mid Voltage A		0.0 ~ 255.0 (240V) 0.0 to 510.0 (480V)	17.2 Vac 34.5 Vac	Programming	109	
E1-09	0308	Minimum Output Frequency Min Frequency		0.0 ~ 200.0 Hz	1.5 Hz	Programming	109	
E1-10	0309	Mid Output Voltage Min Voltage		0.0 ~ 255.0 (240V) 0.0 to 510.0 (480V)	10.3 Vac 20.7 Vac	Programming	109	
E1-11	030A	Mid Output Frequency B Mid Frequency B		Set only when V/f is finely adjusted at rated output range. Adjustment is not normally required.	0.0 ~ 200.0 Hz	0.0 Hz	Programming	109
E1-12	030B	Mid Output Voltage B Mid Voltage B			0.0 ~ 255.0 (240V) 0.0 to 510.0 (480V)	0.0 Vac	Programming	109
E1-13	030C	Base Voltage Base Voltage			0.0 ~ 255.0 (240V) 0.0 to 510.0 (480V)	0.0 Vac	Programming	109
Motor Setup								
E2-01	030E	Motor Rated Current Motor Rated FLA	Set to the motor nameplate full load amps.	10 ~ 200 %	kVA Dependent	Pump Quick Setup	110	
E2-03	030F	No-Load Current	Sets the magnetizing current of the motor.	kVA Dependent	kVA Dependent	Programming	110	
E2-04	0311	Number of Motor Poles Number of Poles	Set to the number of poles. Used for no-flow detection function and for the calculation of rpm related parameters.	2 ~ 48	2	Pump Quick Setup	110	
E2-05	0312	Motor Line-to-Line Resistance Term Resistance	Phase to phase motor resistance, normally set by the autotuning routine.	0.000 ~ 65.000	kVA Dependent	Programming	—	
Communication Option Setup								
F6-01	03A2	Operation Selection after Communication Error Com Bus Flt Sel	Sets the stopping method for option PCB communications error (BUS fault). Active only when a communications option PCB is installed and when b1-01 or b1-02 = 3. 0: Ramp to Stop 1: Coast to Stop 2: Fast-Stop 3: Alarm Only	0 ~ 3	1	Programming	—	
F6-02	03A3	Input Level of External Fault from Communication Option Card EF0 Detection	0: Always detected 1: Detected only during run	0 ~ 1	0	Programming	—	
F6-03	03A4	Stopping Method for External Fault from Communication Option Card EF0 Fault Action	0: Ramp to Stop 1: Coast to Stop 2: Fast-Stop 3: Alarm Only	0 ~ 3	1	Programming	—	

Parameter No.	Addr. Hex	Parameter Name Digital Operator Display	Description	Setting Range	Factory Setting	Menu Location	Page No.
F6-05	03A6	Current Monitor Display Unit Selection Current Unit Sel	0: A Display 1: 100 % / 8192 (Drive Rated Current)	0 ~ 1	0	Programming	—
			Digital Inputs				
H1-01	0400	Terminal S3 Function Selection Terminal S3 Sel	0: 3-wire control FWD/REV selection for 3-wire sequence 1: Local/Remote Sel Hand/Auto Selection - Closed = Hand, Open = Auto 2: Option/Inv Sel Selects source of speed command and sequence. Closed = b1-01 & b1-02, Open = Option Card 3: Multi-Step SP1 Closed = speed command from d1-02 or Aux Terminal. Open = speed command determined by b1-01. 4: Multi-Step SP2 Closed = speed command from d1-03 or d1-04. Open = speed command determined by b1-01. 7: Multi-Acc/Dec 1 Closed = Accel & Decel Ramps determined by C1-03 & C1-04. Open = Accel & Decel Ramps determined by C1-01 & C1-02. 8: Ext BaseBlk N.O. Closed = Output transistors forced off, Open = Normal operation. 9: Ext BaseBlk N.C. Closed = Normal Operation, Open = Output transistors forced off. A: Acc/Dec RampHold Closed = Acceleration suspended and speed held, Open = Normal Operation. C: Term A2 Enable Closed = Terminal A2 is active, Open = Terminal A2 is disabled. F: Term Not Used Terminal has no effect. 10: MOP Increase Closed = Speed Command Increases, Open = Speed Command Held. Must be set in conjunction with MOP Decrease and b1-02 must be set to 1. 11: MOP Decrease Closed = Speed Command Decreases, Open = Speed Command Held. Must be set in conjunction with MOP Increase and b1-02 must be set to 1.	0 ~ 87	24	Programming	—
H1-02	0401	Terminal S4 Function Selection Terminal S4 Sel	14: Fault Reset Closed = Resets the drive after the fault and the run command have been removed. 15: Fast-Stop N.O. Closed = Drive decelerates using C1-09, regardless of run command status. 17: Fast-Stop N.C. Closed = Normal operation. Open = Drive decelerates using C1-09, regardless of run command status. 18: Timer Function Input for independent timer, controlled by b4-01 and b4-02. Used in conjunction with a multi-function digital output. 19: PI Disable Turns off the PI controller, and PI setpoint becomes speed command. 1B: Program Lockout Closed = All parameter settings can be changed. Open = Only speed command at U1-01 can be changed.	0 ~ 87	14	Programming	—
H1-03	0402	Terminal S5 Function Selection Terminal S5 Sel	14: Fault Reset Closed = Resets the drive after the fault and the run command have been removed. 15: Fast-Stop N.O. Closed = Drive decelerates using C1-09, regardless of run command status. 17: Fast-Stop N.C. Closed = Normal operation. Open = Drive decelerates using C1-09, regardless of run command status. 18: Timer Function Input for independent timer, controlled by b4-01 and b4-02. Used in conjunction with a multi-function digital output. 19: PI Disable Turns off the PI controller, and PI setpoint becomes speed command. 1B: Program Lockout Closed = All parameter settings can be changed. Open = Only speed command at U1-01 can be changed.	0 ~ 87	3: 2-wire 0: 3-wire	Programming	—

Parameter No.	Addr. Hex	Parameter Name Digital Operator Display	Description	Setting Range	Factory Setting	Menu Location	Page No.
H1-04 (continued on next page)	0403	Terminal S6 Function Selection Terminal S6 Sel	<p>20: External Pump Fault, Normally Open, Always Detected, Ramp To Stop</p> <p>21: External Pump Fault, Normally Closed, Always Detected, Ramp To Stop</p> <p>22: External Pump Fault, Normally Open, During Run, Ramp To Stop</p> <p>23: External Pump Fault, Normally Closed, During Run, Ramp To Stop</p> <p>24: External Pump Fault, Normally Open, Always Detected, Coast To Stop</p> <p>25: External Pump Fault, Normally Closed, Always Detected, Coast To Stop</p> <p>26: External Pump Fault, Normally Open, During Run, Coast To Stop</p> <p>27: External Pump Fault, Normally Closed, During Run, Coast To Stop</p> <p>28: External Pump Fault, Normally Open, Always Detected, Fast-Stop</p> <p>29: External Pump Fault, Normally Open, Always Detected, Fast-Stop</p> <p>2A: External Pump Fault, Normally Open, During Run, Fast-Stop</p> <p>2B: External Pump Fault, Normally Closed, During Run, Fast-Stop</p> <p>2C: External Pump Fault, Normally Open, Always Detected, Alarm Only</p> <p>2D: External Pump Fault, Normally Closed, Always Detected, Alarm Only</p> <p>2E: External Pump Fault, Normally Open, During Run, Alarm Only</p> <p>2F: External Pump Fault, Normally Closed, During Run, Alarm Only</p> <p>30: PID Integral Reset</p> <p>31: PID Integral Hold</p> <p>34: PI SFS Cancel</p> <p>36: Option/Inv Sel 2</p> <p>Selects source of speed command and sequence. Closed = Option Card, Open = b1-01 & b1-02.</p> <p>60: Motor Preheat Applies current to create heat to avoid condensation. Closed = Apply amount of current as set in parameter b2-09.</p> <p>61: Speed Search 1</p> <p>When closed as a run command is given, drive does a speed search starting at maximum frequency (E1-04). (Current detection.)</p> <p>62: Speed Search 2</p> <p>When closed as a run command is given, drive does a speed search starting at speed command. (Current detection.)</p> <p>64: Speed Search 3</p> <p>67: Com Test Mode - Used to test RS-485/422 interface. Direction determined by fwd/rev input. 3-wire control Only.</p> <p>6A: Drive Enable - Closed = Drive will accept run command. Open = Drive will not run. If running, drive will stop per b1-03.</p> <p>6B: Com/Inv Sel - Selects source of speed command and sequence Closed = Serial Communication (R+,R-,S+,S-), Open = b1-01 & b1-02</p> <p>6C: Com/Inv Sel 2</p> <p>73: Low City Press <0034></p> <p>Indicates that sufficient / insufficient pressure is present on the inlet to the pump. Used mainly for pressure booster stations. When P1-01 = 3, an alarm condition (see parameters P4-21 and P4-22) will cause drives in the network to stop running and show a "Net Pump Err" message.</p> <p>75: Reset Accum <0034></p> <p>Closed: Volume accumulated will be reset to zero (and held at zero if digital input remains closed).</p> <p>76: High Water Level <0034></p> <p>Function will be active whenever the drive is running. Function logic depends on parameter P1-15 (Water DI Config).</p> <p>P1-15 = 0 or 1 (Normally Open)</p> <p>Closed: High Water Level Fault</p> <p>Open: Reservoir / Tank is filled to normal level.</p> <p>P1-15 = 2 or 3 (Normally Closed)</p> <p>Closed: Reservoir / Tank is filled to normal level.</p> <p>Open: High Water Level Fault</p> <p>80: Hand Mode</p> <p>Function Active in Stopped and Auto Mode.</p> <p>Closed: Hand mode operation as defined in P1-14.</p> <p>Open: Stop Mode when with no incoming run command.</p> <p>Note: Input not active when b1-02 is set for 0 – Operator.</p>	0 ~ 87	80	Programming	—

Parameter No.	Addr. Hex	Parameter Name Digital Operator Display	Description	Setting Range	Factory Setting	Menu Location	Page No.
H1-04	0403		81: Disable Sleep Mode Function Active in Auto Mode. Closed: Disables sleep function, Feedback Drop Detection and Over cycle protection. Open: Sleep function, Feedback Drop Detection and Over cycle protection enabled. 82: Sleep Activation Active in Auto Mode. Closed: Drive will go to sleep (External Digital Input). Open: No function.				
H1-05	0404	Terminal S7 Function Selection Terminal S7 Sel	83: Thermostat Fault, Function Active in Auto Mode. Closed: Drive will trip on "Thermostat Fault". Open: Thermostat fault not active. Open: Low Water Level Fault. 84: Pre-charge Closed: Disables pre-charge function. Open: Pre-charge function enabled. 85: Low Water Level <0034> Function Active in Auto Mode during normal operation, also used with pre-charge function. Function logic depends on parameter P1-15 (Water DI Config). P1-15 = 0, or 2 (Normally open). Closed: Low Water Level Fault. Open: Reservoir/Tank is filled to normal level. P1-15 = 1 or 3 (Normally Closed). Closed: Reservoir/Tank is filled to normal level. Pre-charge function: Function uses low water level input as "Tank / Reservoir" feedback to indicate water level reached. IMPORTANT Program P1-15 to 0 or 2 when the "Low Water" function is not used. 86: Fixed Speed Auto Function Active in Auto Mode Only, Pre-charge and Thrust Bearing function have a higher priority. When fixed speed auto is active (closed) drive disabled Sleep Mode and Lead / Lag operation. Closed: Drive runs at P3-02 frequency, PI Control disabled Open: Drive runs normal operation auto mode. 87: Thermostat Fault, Normally Closed <0032> Function Active in Auto Mode. Closed: Thermostat fault not active. Open: Drive will trip on "Thermostat Fault".	0 ~ 87	84	Programming	—
H1-12 ◆ <0034>	87A	External Fault 3 Delay Time EF3 Delay Time	Sets the amount of time delay applied to the EF3 fault. (20 ≤ H1-01 ≤ 2F)	0.00 ~ 300.00 s	0.00 s	Programming	
H1-13 ◆ <0034>	87B	External Fault 4 Delay Time EF4 Delay Time	Sets the amount of time delay applied to the EF4 fault. (20 ≤ H1-02 ≤ 2F)	0.00 ~ 300.00 s	0.00 s	Programming	
H1-14 ◆ <0034>	87C	External Fault 5 Delay Time EF5 Delay Time	Sets the amount of time delay applied to the EF5 fault. (20 ≤ H1-03 ≤ 2F)	0.00 ~ 300.00 s	0.00 s	Programming	
H1-15 ◆ <0034>	87D	External Fault 6 Delay Time EF6 Delay Time	Sets the amount of time delay applied to the EF6 fault. (20 ≤ H1-04 ≤ 2F)	0.00 ~ 300.00 s	0.00 s	Programming	
H1-16 ◆ <0034>	87E	External Fault 7 Delay Time EF7 Delay Time	Sets the amount of time delay applied to the EF7 fault. (20 ≤ H1-05 ≤ 2F)	0.00 ~ 300.00 s	0.00 s	Programming	

◆ Denotes that parameter can be changed when the drive is running.

Parameter No.	Addr. Hex	Parameter Name Digital Operator Display	Description	Setting Range	Factory Setting	Menu Location	Page No.
Digital Outputs							
H2-01	040B	Terminal M1-M2 Function Selection Term M1-M2 Sel	0: During RUN 1 = Closed when a run command is input or the drive is outputting voltage. 1: Zero Speed = Closed when drive output frequency is less than Fmin (E1-09). 2: Fref/Fout Agree 1 = Closed when drive output speed equals the speed command within the bandwidth of L4-02. 3: Fref/Set Agree 1 = Closed when the drive output speed and the speed command are equal to the value in L4-01 within the bandwidth of L4-02. 4: Freq Detect 1 = Closed when the drive output speed is less than or equal to the value in L4-01, with hysteresis determined by L4-02. 5: Freq Detect 2 = Closed when the drive output speed is greater than or equal to the value in L4-01, with hysteresis determined by L4-02. 6: Inverter Ready = Closed when the drive is not in a fault state, and not in program mode. 7: DC Bus Undervolt = Closed when the DC bus voltage falls below the UV trip level (L2-05). 8: Base Blk 1 = Closed when the drive is not outputting voltage. 9: Operator Reference = Closed when the speed command is coming from the digital operator. A: Remote/Auto Oper = Closed when the run command is coming from the digital operator. B: Trq Det 1 N.O. - Closes when the output current exceeds the value set in parameter L6-02 for more time than is set in parameter L6-03. C: Loss of Ref - Closes when the drive has detected a loss of analog speed command. Speed command is considered lost when it drops 90 % in 0.4 seconds. Parameter L4-05 determines drive reaction to a loss of speed command. D: DB Overheat. E: Fault - Closes when the drive experiences a major fault. F: Not Used 10: Minor Fault - Closes when drive experiences a minor fault or alarm. 11: Reset Cmd Active - Closes when the drive receives a reset command from terminals or serial comms. 12: Timer Output - Output for independent timer, controlled by b4-01 and b4-02. Used in conjunction with a multi-function digital input. 17: Trq. Det 1 N.C. - Opens when the output current exceeds the value set in parameter L6-02 for more time than is set in parameter L6-03. 1A: Reverse Dir - Closes when the drive is running in the reverse direction. 1E: Restart Enabled - Closes when the drive is performing an automatic restart. Automatic restart is configured by parameter L5-01. 1F: Overload (OL1) - Closes before a motor overload occurs. (90 % of OL1 time). 20: OH Prealarm - Closes when the drive's heatsink temperature exceeds the setting of parameter L8-02. 38: Drive Enable - Closes when the drive enable input is active. 39: Waiting to Run - Closes during the time after a run command is issued, but the drive is not running due to the time set in parameter b1-10. 3A: OH Freq Reduce 3B: Run Src Com/Opt 3D: Cooling Fan Err = Closed during internal cooling fan failure. 40: Pump 2 Control Open: Shutdown Additional Pump 2. Closed: Start Additional Pump 2. Function Active in multiplex mode. Contactor control for second pump. 41: Pump 3 Control Open: Shutdown Additional Pump 3. Closed: Start Additional Pump 3. Function Active in multiplex mode. Contactor control for second pump.	0 ~ 57	40	Programming	—
H2-02 (continued on next page)	040C	Terminal M3-M4 Function Selection Term M3-M4 Sel	11: Reset Cmd Active - Closes when the drive receives a reset command from terminals or serial comms. 12: Timer Output - Output for independent timer, controlled by b4-01 and b4-02. Used in conjunction with a multi-function digital input. 17: Trq. Det 1 N.C. - Opens when the output current exceeds the value set in parameter L6-02 for more time than is set in parameter L6-03. 1A: Reverse Dir - Closes when the drive is running in the reverse direction. 1E: Restart Enabled - Closes when the drive is performing an automatic restart. Automatic restart is configured by parameter L5-01. 1F: Overload (OL1) - Closes before a motor overload occurs. (90 % of OL1 time). 20: OH Prealarm - Closes when the drive's heatsink temperature exceeds the setting of parameter L8-02. 38: Drive Enable - Closes when the drive enable input is active. 39: Waiting to Run - Closes during the time after a run command is issued, but the drive is not running due to the time set in parameter b1-10. 3A: OH Freq Reduce 3B: Run Src Com/Opt 3D: Cooling Fan Err = Closed during internal cooling fan failure. 40: Pump 2 Control Open: Shutdown Additional Pump 2. Closed: Start Additional Pump 2. Function Active in multiplex mode. Contactor control for second pump. 41: Pump 3 Control Open: Shutdown Additional Pump 3. Closed: Start Additional Pump 3. Function Active in multiplex mode. Contactor control for second pump.	0 ~ 57	41	Programming	—

Parameter No.	Addr. Hex	Parameter Name Digital Operator Display	Description	Setting Range	Factory Setting	Menu Location	Page No.
H2-02 (continued)	040C	Terminal M3-M4 Function Selection Term M3-M4 Sel	<p>42: Pump Fault Function Active in hand, auto, pre-charge and thrust mode Open: No Dedicated Pump Faults are active. Closed: Dedicated pump fault active (Low Feedback Fault, High Feedback Fault, Over Cycling Fault, Pump Protection Fault, Thermostat Fault, Low Water Fault, Ext. Pump Fault).</p> <p>43: Mot 2 Alternate <0034> Used in conjunction with the 2-motor alternation function. Open: Motor 1 in use (or 2-motor alternation is disabled). Closed: Motor 2 in use.</p> <p>44: Sleep Active <0034> Closed: Drive is in the sleep mode.</p> <p>45: Start Lvl Delay <0034> Closed: During the Start Level Delay Time (P1-05). Feedback has dropped below the P1-04 level and the drive is delaying running.</p> <p>46: Thrust Bearing <0034> Closed: The Thrust Bearing feature is active (output frequency is between zero and P4-05).</p> <p>47: Pre-charge <0034> Closed: The Pre-charge feature is active (configured by P4-01 ~ P4-03). -OR- Closed: The Pre-charge 2 feature is active (configured by P4-12 ~ P4-13).</p> <p>48: High Feedback <0034> Closed: During a "High FB / Water" Fault. -OR- Closed: During a "Low Feedback" Alarm.</p> <p>49: Low Feedback <0034> Closed: During a "High FB / Water" Fault. -OR- Closed: During a "Low Feedback" Alarm.</p> <p>4A: Transducer Loss <0034> Closed: Feedback Loss has been detected (configured by b5-12 ~ b5-14). -OR- Closed: Feedback Loss has been detected on A1 (dual-zone PI). -OR- Closed: During a "FBL - Feedback Loss Fault".</p> <p>4B: Set-point Not Met <0034> Closed: During an "NMS - Set-point Not Met" Fault. -OR- Closed: Feedback level is outside of the P1-11 window. (P1-12 time delay is not applied). Note: If P1-11 is set to zero, this digital output will always be open.</p> <p>4C: Loss of Prime <0034> Closed: During a "LOP - Loss Of Prime" Fault. -OR- Closed: Output current is below the P1-14 level. Note: If P1-14 is set to zero, this digital output will always be open.</p> <p>4D: Thermostat Fault <0034> Closed: Thermostat Fault is present.</p> <p>4E: Low Flow <0034> Closed: During the "Low Flow Fault" condition. -OR- Closed: During a low flow condition as set by P6-04 ~ P6-06 (includes "Low Flow Alarm").</p> <p>4F: Accum Level <0034> Closed: Accumulated level has exceeded the P6-09 and P6-10 setting. -OR- Closed: During the "Accum Level" Fault.</p> <p>50: Utility Delay <0034> Closed: Drive is stopped and is waiting for the utility delay timer to expire (configured by P4-11).</p> <p>51: Run / Stop-Stop <0034> Closed: Drive is stopped due to the run / stop control (P4-18 and P4-19) -OR- Closed: Drive is stopped because the number of run / stop cycles has completed. (P4-20)</p> <p>52: Run / Stop - Finish <0034> Closed: Drive is stopped because the number of run / stop cycles has completed. (P4-20)</p> <p>53: Anti-Jam / De-Scale <0034> Closed: When the Anti-Jam or the De-Scale features are active (configured by P7-XX).</p> <p>54: During Run 2 <0034> Closed: Whenever the drive is outputting voltage to the motor (not base-blocked).</p>	0 ~ 57	41	Programming	—

Parameter No.	Addr. Hex	Parameter Name Digital Operator Display	Description	Setting Range	Factory Setting	Menu Location	Page No.
H2-02 (continued)	040C	Terminal M3-M4 Function Selection Term M3-M4 Sel	55: Lube Pump <0034> Closed: When the Lube Pump Feature is active. This will energize for the time set in parameter P4-23 each time the drive is supposed to start. The drive will delay starting for the P4-23 time. 56: High Flow <0034> Closed: During the "High Flow Fault" condition. -OR- Closed: During a high flow condition as set by P6-12 ~ P6-14 (included "High Flow Alarm") 57: Low Water Level <0034> Closed: During the "Low Water Level" condition as set by P8-07 and P8-08. -OR- Closed: During the LOWWL - Low Water Level Fault". This will energize if the level in the well drops below the Low Level Detection Level (P8-07) for more than the Low Level Detection Delay Time (P8-08), or if there is a LOWWL - Low Water Level Fault.	0 ~ 57	41	Programming	—
Analog Inputs							
H3-02 ◆	0411	Terminal A1 Gain Setting Terminal A1 Gain	Sets the speed command when 10 V is input, as a percentage of the maximum output frequency (E1-04).	0.0 ~ 1000.0 %	100.0 %	Programming	111
H3-03 ◆	0412	Terminal A1 Bias Setting Terminal A1 Bias	Sets the speed command when 0 V is input, as a percentage of the maximum output frequency (E1-04).	-100.0 ~ +100.0 %	0.0 %	Programming	111
H3-08	0417	Terminal A2 Signal Level Selection Term A2 Signal	Selects the signal level of Terminal A2. 0: 0 - 10 Vdc (switch S1-2 must be in the off position) 2: 4 - 20 mA (switch S1-2 must be in the on position) 3: 0- 20 mA	0 or 2	2	Programming	112
H3-09	0418	Aux Terminal Function Selection Terminal A2 Sel	Selects what effect the aux terminal has on the drive. 0: Frequency Bias - 0 - 100 % bias 2: Aux Reference B: PI Feedback D: Frequency Bias 2 - 0 - 100 % bias E: Motor Temperature - See parameters L1-03 & L1-04 16: PI Differential 1F: Not Used	0 ~ 1F	B	Programming	114
H3-10 ◆	0419	Terminal A2 Gain Setting Terminal A2 Gain	Sets the percentage when 10 V (20 mA) is input.	0.0 ~ 1000.0 %	100.0 %	Programming	115
H3-11 ◆	041A	Terminal A2 Bias Setting Terminal A2 Bias	Sets the percentage when 0 V (4 mA) is input.	-100.0 ~ +100.0 %	0.0 %	Programming	116
H3-12	041B	Analog Input Filter Time Constant Filter Avg Time Analog Input Fil Tim	Used to "smooth" out erratic or noisy analog input signals.	0.00 ~ 2.00 s	0.30 s	Programming	116
H3-13	041C	Master Frequency Reference Terminal Sel TA1/A2 Select	Determines which terminal will be the main reference source. 0: Main Fref TA1 - Terminal TA1 is the main speed command and Terminal TA2 is the Aux speed command. 1: Main Fref TA2 - Terminal TA2 is the main speed command and Terminal TA1 is the Aux speed command. Only effective when H3-09 is set to 2 "Aux Reference".	0 ~ 1	0	Programming	116
◆ Denotes that parameter can be changed when the drive is running.							
Analog Outputs							
H4-01	041D	Terminal FM Monitor Selection Terminal FM Sel	Selects which monitor will be output on Terminals FM and AC. 1: Frequency Ref (100 % = max. output frequency) 2: Output Freq (100 % = max. output frequency) 3: Output Current (100 % = drive rated current) 6: Output Voltage (100 % = 230 V or 100 % = 460 V) 7: DC Bus Voltage (100 % = 400 V or 100 % = 800 V) 8: Output kWatts (100 % = drive rated power) 15: Term A1 Level 16: Term A2 Level 18: Mot SEC Current (100 % = Motor rated secondary current) 20: SFS Output (100 % = max. output frequency) 24: PI Feedback 31: Not Used 36: PI Input 37: PI Output (100% = max. output frequency) 38: PI Set-point Note: 100% = 10 V DC output x FM gain setting (H4-02).	1 ~ 38 <0032>	2	Programming	—

Parameter No.	Addr. Hex	Parameter Name Digital Operator Display	Description	Setting Range	Factory Setting	Menu Location	Page No.
H4-02 ◆	041E	Terminal FM Gain Setting Terminal FM Gain	Sets Terminal FM output voltage (in percent of 10 V) when selected monitor is at 100 % output.	0.0 ~ 1000.0 %	100.0 %	Programming	—
H4-03 ◆	041F	Terminal FM Bias Setting Terminal FM Bias	Sets Terminal FM output voltage (in percent of 10 V) when selected monitor is at 0 % output.	-110.0 ~ +110.0 %	0.0 %	Programming	—
H4-04	0420	Terminal AM Monitor Selection Terminal AM Sel	Selects which monitor will be output on Terminals AM and AC. 1: Frequency Ref (100 % = max. output frequency) 2: Output Freq (100 % = max. output frequency) 3: Output Current (100 % = drive rated current) 6: Output Voltage (100 % = 230 V or 100 % = 460 V) 7: DC Bus Voltage (100 % = 400 V or 100% = 800 V) 8: Output kWatts (100 % = drive rated power) 15: Term A1 Level 16: Term A2 Level 18: Mot SEC Current (100 % = Motor rated secondary current) 20: SFS Output (100 % = max. output frequency) 24: PI Feedback 31: Not Used 36: PI Input 37: PI Output (100 % = max. output frequency) 38: PI Set-point Note: 100 % = 10 V DC output x AM gain setting (H4-05).	1 ~ 38 <0032>	8	Programming	—
H4-05 ◆	0421	Terminal AM Gain Setting Terminal AM Gain	Sets Terminal AM output voltage (in percent of 10 V) when selected monitor is at 100 % output.	0.0 ~ 1000.0 %	50.0 %	Programming	—
H4-06 ◆	0422	Terminal AM Bias Setting Terminal AM Bias	Sets Terminal AM output voltage (in percent of 10 V) when selected monitor is at 0 % output.	-110.0 ~ +110.0 %	0.0 %	Programming	—
H4-07	0423	Terminal FM Signal Level Selection AO Level Select1	0: 0 - 10 Vdc 2: 4 - 20 mA*	0 or 2	0	Programming	—
H4-08	0424	Terminal AM Signal Level Selection AO Level Select2	0: 0 - 10 Vdc 2: 4 - 20 mA*	0 or 2	0	Programming	—
◆ Denotes that parameter can be changed when the drive is running. * An analog output of 4 - 20 mA cannot be used with the standard terminal board. Therefore an optional terminal board (with shunt connector CN15) is needed.							
Serial Communication Setup							
H5-01	0425	Drive Node Address Serial Com Adr	Selects drive station node number (address) for Terminals R+, R-, S+, S-. Note: An address of "0" disables serial com. Drive power must be cycled before the changes will take effect. *Range is dependent on P9-25, if P1-01 = 3. <0034>	0 ~ 20*	1F	Programming	—
H5-02	0426	Communication Speed Selection Serial Baud Rate	Selects the baud rate for Terminals R+, R-, S+ and S-. 0: 1200 Baud 1: 2400 Baud 2: 4800 Baud (APOGEE FLN) 3: 9600 Baud (Metasys N2) 4: 19200 Baud Note: Drive power must be cycled before the changes will take effect. <0034>	0 ~ 4	3	Programming	—
H5-03	0427	Communication Parity Selection Serial Com Sel	Selects the communication parity for Terminals R+, R-, S+ and S-. 0: No Parity 1: Even Parity 2: Odd Parity Note: Drive power must be cycled before the changes will take effect. <0034>	0 ~ 2	0	Programming	—
H5-04	0428	Stopping Method after Communication Error Serial Flt Sel	Selects the stopping method when a communication error is detected. 0: Ramp to Stop 1: Coast to Stop 2: Fast-Stop 3: Alarm Only	0 ~ 3	3	Programming	—
H5-05	0429	Communication Error Detection Selection Serial Flt Dctt	Enables or disables the communications timeout detection function. 0: Disabled - A communications loss will NOT cause a communications fault. 1: Enabled - If communications are lost for more than the time specified in parameter H5-09, a communications fault will occur.	0 ~ 1	1	Programming	—

Parameter No.	Addr. Hex	Parameter Name Digital Operator Display	Description	Setting Range	Factory Setting	Menu Location	Page No.
H5-06	042A	Drive Transmit Wait Time Transmit WaitTim	Sets the time from when the drive receives data to when the drive sends data.	5 ~ 65 ms	5 ms	Programming	—
H5-07	042B	RTS Control Selection RTS Control Sel	Enables or disables "request to send" (RTS) control: 0: Disabled (RTS is always on) 1: Enabled (RTS turns on only when sending)	0 ~ 1	1	Programming	—
H5-08	042C	Communication Protocol Selection Com Protocol Sel	0: MEMOBUS / Modbus 1: N2 (Metasys) 2: FLN (APOGEE)	0 ~ 2	0	Programming	—
H5-09	0435	Communication Error Detection Time CE Detect Time	Determines how long communications must be lost before a fault is annunciated. Works in conjunction with parameters H5-05 and H5-04.	0.0 ~ 10.0 s	2.0 s	Programming	—
Motor Overload							
L1-01	0480	Motor Overload Protection Selection MOL Flt Sel	Enables or disables the motor thermal overload protection. 0: Disabled 1: Std Fan Cooled (Enabled) 2: Std Blower Cooled 3: Vector Motor	0 ~ 1	1	Programming	—
L1-02	0481	Motor Overload Protection Time MOL Time Const	Determines how much time will elapse prior to a motor overload fault (OL1), when motor amps exceed the value set in parameter E2-01 by 10 % . Actual (OL1) trip time will vary depending on severity of overload.	0.1 ~ 20.0 min	8.0 min	Programming	—
L1-03	0482	Motor Overheat Alarm Operation Selection Mtr OH Alarm Sel	Operation selection when the motor temperature analog input (H3-09 = E) exceeds the OH3 alarm level (1.17 V) 0: Ramp to Stop 1: Coast to Stop 2: Fast-Stop 3: Alarm Only	0 ~ 3	3	Programming	—
L1-04	0483	Motor Overheat Fault Operation Selection Mtr OH Fault Sel	Stopping method when the motor temperature analog input (H3-09 = E) exceeds the OH4 level (2.34 V). 0: Ramp to Stop 1: Coast to Stop 2: Fast-Stop	0 ~ 2	1	Programming	—
L1-05	0484	Motor Temperature Input Filter Time Mtr Temp Filter	Delay Time applied to motor temperature analog input (H3-09 = E) for filtering purposes.	0.00 ~ 10.00 s	0.20 s	Programming	—
Power Loss Ridethru							
L2-01	0485	Momentary Power Loss Detection Selection PwrL Selection	Enables and disables the momentary power loss function. 0: Disabled - Drive trips on (UV1) fault when power is lost. 1: PwrL Ride Thru t - Drive will restart if power returns within the time set in L2-02.* 2: CPU Power Active - Drive will restart if power returns prior to internal power supply shut down.* * In order for a restart to occur, the run command must be maintained throughout the ride thru period.	0 ~ 2	2	Programming	116
L2-02	0486	Momentary Power Loss Ride-thru Time PwrL Ridethru T	Determines the power loss ride-thru time. This value is dependent on the capacity of the drive. Only effective when L2-01 = 1.	0.0 ~ 25.5 s	kVA Dependent	Programming	117
L2-03	0487	Momentary Power Loss Minimum Base Block Time PwrL Baseblock T	Used to allow the residual motor voltage to decay before the drive output turns back on. After a power loss, if L2-03 is greater than L2-02, operation resumes after the time set in L2-03.	0.1 ~ 5.0 s	kVA Dependent	Programming	—
L2-04	0488	Momentary Power Loss Voltage Recovery Ramp Time PwrL V/f Ramp T	The time it takes the output voltage to return to the preset V/f pattern after speed search (current detection mode) is complete.	0.0 ~ 5.0 s	kVA Dependent	Programming	—
L2-05	0489	Undervoltage Detection Level PUV Det Level	Sets the drive's DC Bus undervoltage trip level. If this is set lower than the factory setting, additional AC input reactance or DC bus reactance may be necessary.	Voltage Class Dependent	Voltage Class Dependent	Programming	—

Parameter No.	Addr. Hex	Parameter Name Digital Operator Display	Description	Setting Range	Factory Setting	Menu Location	Page No.
Stall Prevention							
L3-01	048F	Stall Prevention Selection During Accel StallP Accel Sel	0: Disabled (Motor accelerates at active acceleration, C1-01 or C1-03. The motor may stall if load is too heavy or accel time is too short.) 1: General Purpose (When output current exceeds L3-02 level, acceleration stops. It starts to accelerate at current value recovery.) 2: Intelligent (The active acceleration rate, C1-01 or C1-02, is ignored. Acceleration is completed in the shortest amount of time w/o exceeding the current value set in L3-02.	0 ~ 2	1	Programming	—
L3-02	0490	Stall Prevention Level During Accel StallP Accel Lvl	This function is enabled when L3-01 is "1" or "2". Drive rated current is 100 %. Decrease the set value if stalling occurs at factory setting.	0 ~ 200 %	120 %	Programming	—
L3-04	0492	Stall Prevention Selection During Decel StallP Decel Sel	0: Disabled (The drive decelerates at the active deceleration rate, C1-02 or C1-04. If the load is too large or the deceleration time is too short, an OV fault may occur.) 1: General Purpose (The drive decelerates at the active deceleration rate, C1-02 or C1-04, but if the main circuit DC bus voltage reaches the stall prevention level the output frequency will clamp. Deceleration will continue once the DC bus level drops below the stall prevention level.) 2: Intelligent (The active deceleration rate is ignored and the drive decelerates as fast as possible w/o hitting OV fault level.)	0 ~ 3	1	Programming	—
L3-05	0493	Stall Prevention Level During Decel StallP Run Sel	0: Disabled (drive runs a set frequency.) A heavy load may cause the drive to trip on an OC fault. 1: Decel Time 1 (In order to avoid stalling during heavy loading, the drive will start to decelerate at Decel time 1 (C1-02) if the output current exceeds the level set by L3-06. Once the current level drops below the L3-06 level the drive will accelerate back to its set frequency at the active acceleration rate.) 2: Decel Time 2 (Same as setting 1 except the drive decelerates at Decel Time 2 (C1-04).) For 6 Hz or less frequency, stall prevention function during run is disabled regardless of L3-05 set.	0 ~ 2	1	Programming	—
L3-06	0494	Stall Prevention Level During Running StallP Run Level	This function is enabled when L3-05 is "1" or "2". Drive rated current is set as 100 %. Normally, changing the setting is not required. Decrease the set value if stalling occurs at factory setting.	30 ~ 200 %	120 %	Programming	—
Reference Detection							
L4-01	0499	Speed Agreement Detection Level Spd Agree Level	L4-01 and L4-02 are used in conjunction with the multi-function outputs, (H2-01 and H2-02) as a setpoint and hysteresis for a contact closure.	0.0 ~ 200.0 Hz	0.0 Hz	Programming	—
L4-02	049A	Speed Agreement Detection Width Spd Agree Width		0.0 ~ 20.0 Hz	2.0 Hz	Programming	—
L4-05	049D	Frequency Reference Loss Detection Selection Ref Loss Sel	Determines how the drive will react when the frequency reference is lost. 0: Stop (Disabled) - Drive will not run at the frequency reference. 1: Enabled @ % of PrevRef - Drive will run at a percentage (L4-06) of the frequency reference level at the time frequency reference was lost. Note: Only available in the Hand Mode (P5-01 = 0).	0 ~ 1	0	Programming	—
L4-06	04C2	Frequency Reference Level at Loss Frequency Fref at Freq loss	If Frequency Reference loss function is enabled (L4-05 = 1) and Frequency Reference is lost, then the drive will run at reduced frequency reference determined by L4-06. New Fref=Fref at time of loss x L4-06. Note: Only available in the Hand Mode (P5-01 = 0)	0 ~ 1	0	Programming	—
Fault Restart							
L5-01	049E	Number of Auto Restart Attempts Num of Restarts	Determines the number of times the drive will perform an automatic restart.	0 ~ 10	5	Programming	117
L5-02	049F	Auto Restart Operation Selection Restart Sel	Determines if the fault contact activates during an automatic restart attempt. 0: No Flt Relay - fault contact will not activate during an automatic restart. 1: Flt Relay Active - fault contact will activate during an automatic restart.	0 ~ 1	0	Programming	117
L5-03	04A0	Maximum Restart Time After Fault Max Restart Time	If the restart fails (or is not attempted due to a continuing fault condition, e.g. an OV fault) the drive waits the Maximum Restart Time After Fault (L5-03) before attempting another restart. This parameter is not applicable to Loss of Prime Fault.	10.0 ~ 3600.0 s <0032>	20.0 s	Programming	117

Parameter No.	Addr. Hex	Parameter Name Digital Operator Display	Description	Setting Range	Factory Setting	Menu Location	Page No.
Torque Detection							
L6-01	04A1	Torque Detection Selection 1 Load Detection	Determines the drive's response to an overtorque / undertorque condition. Overtorque and Undertorque are determined by the settings in parameters L6-02 and L6-03. 0: Disabled 1: OL@SpdAgree - Alm (Overtorque Detection only active during Speed Agree and Operation continues after detection) 2: OL At RUN - Alm (Overtorque Detection is always active and operation continues after detection) 3: OL@SpdAgree - Flt (Overtorque Detection only active during Speed Agree and drive output will shut down on an OL3 fault.) 4: OL At RUN - Flt (Overtorque Detection is always active and drive output will shut down on an OL3 fault.) 5: LL@SpdAgree - Alm (Undertorque Detection is only active during Speed Agree and operation continues after detection.) 6: LL at RUN - Alm (Undertorque Detection is always active and operation continues after detection.) 7: LL @ SpdAgree - Flt (Undertorque Detection only active during Speed Agree and drive output will shut down on an OL3 fault.) 8: LL At RUN - Flt (Undertorque Detection is always active and drive output will shut down on an OL3 fault.)	0 ~ 8	0	Programming	119
L6-02	04A2	Torque Detection Level 1 Load Det Lvl	Sets the overtorque / undertorque detection level as a percentage of drive rated current.	0 ~ 300 %	15 %	Programming	119
L6-03	04A3	Torque Detection Time 1 Loss Det Time	Sets the length of time an overtorque / undertorque condition must exist before being recognized by the drive. OL3 is then displayed.	0.0 ~ 10.0 s	10.0 s	Programming	119
Hardware Protection							
L8-01	04AD	Internal Dynamic Braking Resistor Protection Selection DB Resistor Prot	0: Not Provided 1: Provided	0 ~ 1	0	Programming	120
L8-02	04AE	Overheat Pre-Alarm Level OH Pre-Alarm Lvl	When the cooling fin temperature exceeds the value set in this parameter, an overheat pre-alarm (OH) will occur.	50 ~ 130 °C	95 °C	Programming	120
L8-03	04AF	Overheat Pre-Alarm Operation Selection OH Pre-Alarm Sel	Drive Operation upon OH Pre Alarm Detection. 0: Ramp to Stop (Decel Time C1-02). 1: Coast to Stop 2: Fast-Stop (Decel Time = C1-09). 3: Alarm Only *0 to 2 is recognized as fault detection, and 3 is recognized as alarm. (For the fault detection, the fault contact operates.) 4: OH Alarm & Reduce (Continue operation and reduce output frequency by L8-19)	0 ~ 4	4	Programming	121
L8-05 <0033>	04B1	Input Phase Loss Protection Selection Ph Loss In Sel	Selects the detection of input current phase loss, power supply voltage imbalance, or main circuit electrostatic capacitor deterioration. 0: Disabled 1: Enabled	0 ~ 1	1	Programming	121
L8-06	04B2	Input Phase Loss Detection Level Ph Loss In Lvl	Monitors the DC Bus current ripple and activates when one of the input phases is lost (PF).	0.0 ~ 25.0	kVA Dependent	Programming	121
L8-07 <0033>	04B3	Output Phase Loss Protection Selection Ph Loss Out Sel	Selects the detection of output current open-phase. When applied motor capacity is too small for drive capacity, output phase loss may be detected inadvertently. In this case, set to 0. 0: Disabled 1: Enabled	0 ~ 1	1	Programming	121
L8-09	04B5	Output Ground Fault Detection Selection Ground Fault Sel	Enables and disables drive output ground fault detection. 0: Disabled 1: Enabled	0 ~ 1	1	Programming	122
L8-10	04B6	Heatsink Cooling Fan Operation Selection Fan On/Off Sel	Controls the Heatsink Cooling Fan Operation. 0: Fan On-Run Mode (Fan will operate only when drive is running and for L8-11 seconds after RUN is removed). 1: Fan Always On (Cooling fan operates whenever drive is powered up.)	0 ~ 1	0	Programming	122
L8-11 <0032>	04B7	Heatsink Cooling Fan Operation Delay Time Fan Delay Time	When L8-10=0 this parameter sets a delay time for Cooling Fan de-energization after the run command is removed or baseblock enabled.	0 ~ 300 s	300 s	Programming	122

Parameter No.	Addr. Hex	Parameter Name Digital Operator Display	Description	Setting Range	Factory Setting	Menu Location	Page No.								
L8-12	04B8	Ambient Temperature Setting Ambient Temp	When the drive is installed in an ambient temperature exceeding its rating, drive overload (OL2) protection level is reduced.	45 ~ 60 °C	45 °C	Programming	—								
L8-15	04BB	OL2 Characteristic Selection at Low Speeds OL2 Sel @ L-Spd	This parameter assists in protecting the output transistor junctions from overheating when output current is high and output frequency is low. 0: Disabled 1: Enabled (L8-18 is active)	0 ~ 1	1	Programming	—								
L8-18	04BE	Soft CLA Selection Soft CLA Sel	Enables and disables current limit "A". 0: Disabled 1: Enabled	0 ~ 1	1	Programming	—								
L8-19	04BF	OH Frequency Reference Reduction Level Fref During OH	Sets the amount of frequency reference reduction when an Overheat Pre-alarm (OH) is detected.	0.0 ~ 100.0 %	20.0 %	Programming	123								
Hunting Prevention															
n1-01	0580	Hunting Prevention Selection Hunt Prev Select	0: Disabled (Hunting prevention function disabled.) 1: Enabled (Hunting prevention function enabled.) If the motor vibrates while lightly loaded, hunting prevention may reduce the vibration. There is a loss of responsiveness if hunting prevention is enabled.	0 ~ 1	1	Programming	—								
n1-02	0581	Hunting Prevention Gain Setting Hunt Prev Gain	Gain setting for the Hunting Prevention Function. If the motor vibrates while lightly loaded and n1-01 = 1, increase the gain by 0.1 until vibration ceases. If the motor stalls while n1-01 = 1 decrease the gain by 0.1 until the stalling ceases.	0.00 ~ 2.50	1.00	Programming	—								
High-Slip Braking															
n3-01	0588	High-Slip Braking Deceleration Frequency Width HSB Decel Width	Sets how aggressively the drive decreases the output frequency as it stops the motor. If overvoltage (OV) faults occur during HSB, this parameter may need to be increased. Note: Function Deactivated	1.0 ~ 20.0 %	5 %	Programming									
n3-02	0589	High-Slip Braking Current Limit HSB Current Ref	Sets the maximum current to be drawn during a HSB stop. Higher n3-02 settings will shorten motor stopping times but cause increased motor current and therefore, increased motor heating. Note: Function Deactivated	100.0 ~ 200.0 %	150 %	Programming									
n3-03	058A	High-Slip Braking Dwell Time at Stop HSB DwellTim@ Stp	Sets the amount of time the drive will dwell at E1-09 (Minimum Frequency). If this time is set too low, the machine inertia can cause the motor to rotate slightly after the HSB stop is complete and drive output is shut off. Note: Function Deactivated	0.00 ~ 10.0 s	1.0 s	Programming									
n3-04	058B	High-Slip Braking Overload Time HSB OL Time	Sets the time required for a HSB Overload Fault to occur when the drive output frequency does not change for some reason during a HSB stop. Normally this does not need to be adjusted. Note: Function Deactivated	30.0 ~ 1200.0 s	40 s	Programming									
Monitor Select															
o1-01 ◆	0500	User Monitor Selection User Monitor Sel	Selects which monitor will be displayed upon power-up when o1-02 = 4.	6 ~ 94	6	Programming	123								
o1-02	0501	User Monitor Selection After Power-Up Power-On Monitor	Selects which monitor will be displayed upon power-up. 1: Auto: Set-point 2: Output Freq 3: Output Current 4: User Monitor (set by o1-01)	1 ~ 4	1	Programming	123								
o1-05	0504	LCD Brightness Adjustment LCD Contrast	<table border="1" style="width: 100%; border-collapse: collapse;"> <thead> <tr> <th>Set Value</th> <th>Description</th> </tr> </thead> <tbody> <tr> <td>5</td> <td>LCD display becomes dark</td> </tr> <tr> <td>3</td> <td>Standard setting</td> </tr> <tr> <td>1</td> <td>LCD display becomes light</td> </tr> </tbody> </table>	Set Value	Description	5	LCD display becomes dark	3	Standard setting	1	LCD display becomes light	0 ~ 5	3	Programming	124
Set Value	Description														
5	LCD display becomes dark														
3	Standard setting														
1	LCD display becomes light														
o1-06	0517	User Monitor Selection Mode Monitor Mode Sel	Selects the "U1" monitors displayed on the 4th and 5th lines of the digital operator display. 0: 3 Mon Sequential (Displays the next 2 sequential U1 monitors.) 1: 3 Mon Selectable (Displays U1 monitors set by o1-07 and o1-08.)	0 ~ 1	1**	Programming	124								

◆ Denotes that parameter can be changed when the drive is running.

Parameter No.	Addr. Hex	Parameter Name Digital Operator Display	Description	Setting Range	Factory Setting	Menu Location	Page No.
o1-07	0518	Second Line User Monitor Selection 2nd Monitor Sel	Sets the "U1" monitor always displayed on the 4th line of the digital operator display. Effective only when o1-06 = 1.	1 ~ 94	2	Programming	124
o1-08	0519	Third Line User Monitor Selection 3rd Monitor Sel	Sets the "U1" monitor always displayed on the 5th line of the digital operator display. Effective only when o1-06 = 1.	1 ~ 94	91	Programming	124
Key Selections							
o2-01	0505	Local / Remote Key Function Selection Local/Remote Key	Has no function when HOA operator is connected. 0: Disabled 1: Enabled	0 ~ 1	1	Programming	—
o2-02	0506	OFF Key Function During Auto Run Oper OFF Key	Determines if the off key on the digital operator will stop the drive when drive is operating from external terminals or serial communications. 0: Disabled 1: Enabled	0 ~ 1	1	Programming	—
o2-03	0507	User Parameter Default Value User Defaults	Allows storing of current parameter values as a User Initialization Selection at parameter A1-03. 0: No Change (No user parameter set active). 1: Set Defaults (Saves current parameter settings as user initialization. A1-03 now allows selecting <1110> for user initialization. 2: Clear All (Clears the currently saved user initialization. A1-03 no longer allows selecting <1110>).	0 ~ 2	0	Programming	—
o2-04	0508	Drive / kVA Selection Inverter Model #	Sets the kVA of the drive. Enter the number based on drive model #. Use the □□□□ portion of the CIMR-P7□□□□-107 Model Number.	0 ~ FF	kVA Dependent	Programming	—
o2-05	0509	Frequency Reference Setting Method Selection Operator M.O.P.	Determines if the Data / Enter key must be used to input a frequency reference from the digital operator. 0: Disabled - Data / Enter key must be pressed to enter a frequency reference. 1: Enabled: -Data / Enter key is not required. The frequency reference is adjusted by the up and down arrow keys on the digital operator without having to press the data / enter key.	0 ~ 1	0	Programming	—
o2-06	050A	Operation Selection when Digital Operator is Disconnected Oper Detection	Determines if the drive will stop when the digital operator is removed. 0: Disabled - The drive will not stop when the digital operator is removed. 1: Enabled - The drive will fault (OPR) and coast to stop when the operator is removed.	0 ~ 1	1	Programming	125
o2-07	050B	Cumulative Operation Time Setting Elapsed Time Set	Sets the initial value of the elapsed operation timer.	0 ~ 65535 hr	0 hr	Programming	125
o2-08	050C	Cumulative Operation Time Selection Elapsed Time Run	Sets how time is accumulated for the elapsed timer (o2-07). 0: Power-On Time (Time accumulates whenever drive is powered). 1: Running Time (Time accumulates only when drive is running)	0 ~ 1	1	Programming	125
o2-10	050E	Cumulative Cooling Fan Operation Time Setting Fan ON Time Set	Sets the initial value of the heatsink fan operation time.	0 ~ 65535 hr	0 hr	Programming	—
o2-12	0510	Fault Trace / Fault History Clear Function FLT Trace Init	Clears the fault memory contained in the U2 and U3 monitors. 0: Disabled (no effect). 1: Enabled - resets U2 and U3 monitors, and returns o2-12 to zero.	0 ~ 1	0	Programming	—
o2-14	0512	kWh User Monitor (U1-29) Initialization kWh MonitorClear	Used to reset the kilowatt Hour monitor to zero 0: Disabled (no change) 1: Clear all - Resets U1-29 to zero and returns o2-14 to zero.	0 ~ 1	0	Programming	—
Copy Function							
o3-01	0515	Copy Function Selection Copy Function Sel	This parameter controls the copying of parameters to and from the digital operator. 0: COPY SELECT (no function) 1: INV -> OP READ - All parameters are copied from the drive to the digital operator. 2: OP -> INV WRITE - All parameters are copied from the digital operator into the drive. 3: OP <-> INV VERIFY - Parameter settings in the drive are compared to those in the digital operator. Note: When using the copy function, the drive model number and software number (U1-14) must match or an error will occur.	0 ~ 3	0	Programming	125

Parameter No.	Addr. Hex	Parameter Name Digital Operator Display	Description	Setting Range	Factory Setting	Menu Location	Page No.
o3-02	0516	Read Allowed Selection Read Allowable	Enables and disables all digital operator copy functions. 0: Disabled - No digital operator copy functions are allowed. 1: Enabled - Copying allowed	0 ~ 1	0	Programming	126
Pump Basic							
P1-01	0600	Pump Mode Pump Mode	Select type of control operation. 0: Drive Only (Simplex) 1: Drive + 1 Pump 2: Drive + 2 Pumps 3: Memobus network <0034>	0 ~ 3	0	Programming	—
P1-02	0601	System Units System Units	0: WC:InchOfWater 1: psi:lb / SqrInch 2: GPM:Gallons / min 3: F:DegFahrenheit 4: CFM:Cubic ft / min 5: CMH:Cubic m / hr 6: LPH:Liters / hr 7: LPS:Liters / s 8: Bar:Bar 9: Pa:Pascals 10: C:DegCelsius 11: Ft: Feet <0032> 12:%: Percent 13: rpm: Revs / min (Note 1) <0034> 14: Hz: Hertz (Note 1) <0034>	0 ~ 14	1	Programming	—
P1-03	0602	Feedback Device Scaling Fb Dev Scaling	Scaling of feedback device in user units (P1-02=1, e.g. 150 psi). Digits 1 through 4 set the maximum feedback number. Digit 5 determines the number of decimal places. Digit 5 = 0: Number format is XXXX Digit 5 = 1: Number format is XXX.X Digit 5 = 2: Number format is XX.XX Digit 5 = 3: Number format is X.XXX Examples: 01000 = 1000 13000 = 300.0 25000 = 50.00 32000 = 2.000	1 ~ 36000 (system units P1-02)	00145	Programming	—
P1-04 ◆	0603	Start Level Start Level	Drive starts when the feedback level drops below the start level for a time specified in P1-05. This level also specifies the wake up level when the drive is in Sleep Mode. If set to a negative value, the feedback level must drop by this amount below the setpoint. <0034> Note: When PID operates in the reverse mode, the feedback value has to rise above the start level for the time programmed in P1-05 for the system to start. A value of 0 disables this function. If P1-01 = 3, the function is active only on the first drive in the network. <0034>	- 999.9 ~ 999.9 (system units P1-02)	0.0 (system units P1-02)	Pump Quick Setup	—
P1-05 ◆	0604	Start Level Delay Time S-Lvl Delay Time	Drive starts when the feedback level drops below the start level for a time specified in P1-05.	0 ~ 3600 s	1 s	Programming	—
P1-06 ◆	0605	Minimum Pump Frequency Min. Pump Freq	Minimum drive frequency when operated in the auto mode. Programmed value will limit minimum PID output. Minimum value has to be programmed to a value smaller than P3-09 and P3-10 when drive is operating in the multiplex mode (P1-01).	0.0 ~ 120.0 Hz	40.0 Hz	Pump Quick Setup	128
P1-07 ◆	0606	Low Feedback Level Low FB Level	The drive will display a “Low Feedback (LFB)” alarm when the feedback level falls below the programmed level. The alarm will turn off when the feedback level rises above the programmed Low Feedback Level plus the Hysteresis Level (P1-13). A value of 0 disables this function. This function is only active during running while operating in the auto mode.	0.0 ~ 6000.0 (system units P1-02)	0.0 (system units P1-02)	Programming	—
P1-08 ◆	0607	Low Feedback Level Fault Delay Time Low Lvl Flt Time	The drive will display a “Low Feedback / Water (LFB / LW)” alarm when the feedback level falls below the programmed level for a time specified in P1-08. The drive will coast to a stop when a fault occurs. A value of 0 disables this function. This function is only active during running while operating in the auto mode. If P1-01 = 3, the function will stop all drives running on the network when the system fault occurs. <0034>	0 ~ 3600 s	5 s	Programming	—

◆ Denotes that parameter can be changed when the drive is running.

(Note 1) When P1-02 = 3, parameter P1-03 will have to be set to (120x E1-04 / E2-04) for proper display. When P1-02 = 14, parameter P1-03 will have to be set to the same value as E1-04 for proper display.

Parameter No.	Addr. Hex	Parameter Name Digital Operator Display	Description	Setting Range	Factory Setting	Menu Location	Page No.
P1-09 ◆	0608	High Feedback Level High FB Level	The drive will display a “High Feedback Level (HFB)” alarm when the feedback level rises above the programmed level. The alarm will turn off when the feedback level falls below the programmed High Feedback Level minus the Hysteresis Level (P1-13). This function is active during running in the hand mode, auto mode, pre-charge and thrust-bearing mode. If P1-01 = 3, parameter P9-18 uses this value to calculate the quick de-stage feedback level. <0034>	0.0 ~ 6000.0 (system units P1-02)	155.0 (system units P1-02)	Programming	—
P1-10 ◆	0609	High Feedback Level Fault Delay Time Hgh Lvl Fht Time	The drive will initiate a “High Feedback Fault (HFB)” when the feedback level rises above the programmed level for a time specified in P1-10. The drive will coast to a stop when a fault occurs. This function is active during running in all operation modes. If P1-01 = 3, the function will stop all drives running on the network when the system fault occurs. <0034>	0 ~ 3600 s	2 s	Programming	—
P1-11 ◆ <0032>	0106	Maximum SetPoint Difference Max Set-point Diff	When the drive is running and the difference between the setpoint and the feedback exceeds the level in P1-11 for the time specified in P1-12, the drive will trip on a “Not Maintaining Set-point (NMS)”. The drive will coast to a stop when a fault occurs. A value of 0 disables this function. This function is only active during running while operating in auto mode. If P1-01 = 3, the function is active on the lead drive, but will stop all drives running on the network when the system fault occurs. <0034>	0.0 ~ 6000.0 (system units P1-02)	0.0 (system units P1-02)	Programming	—
P1-12 ◆ <0032>	0107	Not Maintaining Set-point Time Not Maint SP Tm	Delay time before a Not Maintaining Set-point fault occurs. Pump protection criteria specified in P1-11 must be met for the drive to fault. The drive will coast to a stop when a fault occurs. A value of 0 disables Not Maintaining Set-point fault.	0 ~ 3600 s	60 s	Programming	129
P1-13 ◆	0108	Hysteresis Level Hysteresis Level	Hysteresis Level used for low and high feedback alarm detection. See function P1-07 and P1-09.	0.0 ~ 100.0 (system units P1-02)	0.0 (system units P1-02)	Programming	—
P1-14 ◆	0109	Prime Loss Level Prime Loss Level	Used to detect loss of prime in the pump. If output current drops below this level for the time specified in P1-12 and the output frequency is at fmax, a “Loss Of Prime” fault occurs. The drive will coast to a stop when a fault occurs. If P1-01 = 3, the function is active on the lead drive, but will stop all drives running on the network when the system fault occurs. <0034>	0.0 ~ 1000.0 A	0.0 A	Programming	129
P1-15 ◆	010A	Low / Hi Water Digital Input Configuration Water DI Config <0034>	Sets the type of control operation 0: Low N.O. - Hi N.O. (Low Water Normally Open, High Water Normally Open) <0034> 1: Low N.C. - Hi N.O. (Low Water Normally Closed, High Water Normally Open) <0034> 2: Low N.O. - Hi N.C. (Low Water Normally Open, High Water Normally Closed) <0034> 3: Low N.C. - Hi N.C. (Low Water Normally Closed, High Water Normally Closed) <0034> To use the low water function one of the digital inputs (H1-XX=85) needs to be programmed. The low water input can be used for a low water condition or in combination with the pre-charge function to indicate the reservoir is filled. The low water input fault is only active during running while operating in auto mode.	0 ~ 3	0	Programming	—
P1-16 ◆ <0034>	87F	Loss of Prime Time Prime Loss Time	Delay time before a Loss of Prime fault occurs. Pump protection criteria specified P1-14 must be met for the drive to fault. On fault the drive will coast to a stop.	1 ~ 600 s	20 s	Programming	
◆ Denotes that parameter can be changed when the drive is running.							
Pump Protection							
P2-01	060A	Sleep Level Type Sleep Lvl Type	Sets the sleep type. 0: Output Frequency 1: Output Current 2: Feedback 3: Output Speed (rpm) <0034> 4: Low Flow (Terminal A1 - Flow meter required) <0034> Note: Feedback depends on PID direction operation. Displays a “Sleep” Alarm when active.	0 ~ 4	0	Programming	131

Parameter No.	Addr. Hex	Parameter Name Digital Operator Display	Description	Setting Range	Factory Setting	Menu Location	Page No.
P2-02 ◆	060B	Sleep Level Sleep Level	Sleep activates when selected level (P2-01) reaches programmed sleep level for time specified in P2-03. The level type is determined by P2-01. A value of 0 disables this function. This function is only active during running while operating in auto mode. If P1-01 = 3, the function is active when there is only one drive running on the network. <0034> Display Units for Sleep Level P2-02 when P2-01 is programmed for the following: P2-01=0: Display based on “Hz” P2-01=1: Display based on “A” P2-01=2: Display based on P1-02 Selection P2-01=3: Display based on “rpm” <0034> P2-01=4: Display based on P6-02 Selection <0034> Note: When P2-01 is set for a value of 2, display units will be dependent on P1-02 setting. If P2-02 = 0, pump will sleep at minimum speed.	0.0 ~ 6000.0	0.0	Programming	131
P2-03 ◆	060C	Sleep Delay Time Sleep Delay Time	Delay time before drive enters sleep mode when criteria is met as defined by parameter P2-02.	0 ~ 3600 s	5 s	Programming	131
P2-04 ◆	060D	Delta Sleep Feedback Drop Level D Fb Drop Level	When the drive enters sleep mode, the software monitors the feedback to detect a flow-no flow condition. If the PID Error (setpoint minus feedback) exceeds the programmed level P2-04 within the programmed time (P2-05) and the output frequency is greater than the minimum frequency (P1-06), the sleep operation deactivates and the drive returns to normal operation. A value of 0 disables this function.	0.0 ~ 6000.0 (system units P1-02)	0.0 (system units P1-02)	Programming	—
P2-05 ◆	060E	Feedback detection drop time. FB Drop DetTime	Defines the time window in which the software monitors the feedback to detect a flow-no flow condition. Works in conjunction with parameter P2-04.	0 ~ 3600 s	10 s	Programming	—
P2-06 ◆	060F	Sleep Mode: Cycling Protection Cycle Protection	Maximum number of cycles allowed within the time specified in P2-07 before the drive initiates a “Pump Cycle Fault (PCF)”. One Cycle is defined when the drive transfers from normal operation in auto mode to sleep mode. A value of 0 disables this function. If P1-01 = 3, the function is active when there is only one drive running on the network. <0034>	0 ~ 10	0	Programming	—
P2-07 ◆	0610	Sleep Mode: Maximum Cycling Protection Time Max. Cycle Time	Maximum time allowed between cycles. When no cycling occurs within the programmed time, the drive will reset the internal cycle register. Works in conjunction with P2-06.	0 ~ 3600 s	300 s	Programming	—
P2-08	0611	Over Cycling Mode Over Cycle Mode	Sets the Over Cycle Mode: 0: Disabled 1: Alarm 2: Pump Over Cycle Fault (POC) 3: Auto Compensation	0 ~ 3	0	Programming	—
P2-09	0612	Set-point Compensation Set-point Comp	Allows for the software to automatically compensate the setpoint in case of excessive cycling.	0.0 ~ 6000.0 (system units P1-02)	0.0 (system units P1-02)	Programming	—
P2-10	0613	Maximum Set-point Compensation Max. SP Comp	Maximum allowable setpoint compensation for the over-cycling function.	0.0 ~ 6000.0 (system units P1-02)	0.0 (system units P1-02)	Pump Quick Setup	—
P2-11	010B	No-Flow Activation Level NF Act. Level	When the motor rpm falls below the programmed level in P2-12, the no-flow detection will activate. A value of 0 disables this function. If P1-01 = 3, the function is active on the lead drive. <0034>	0 ~ 24000 rpm	0 rpm	Programming	—
P2-12	010C	No-Flow Detection Bandwidth NF Det.Bandwidth	Sets the motor rpm fluctuation bandwidth. No-flow activates when the motor rpm remains within the programmed bandwidth in P2-12 for a time specified in parameter P2-13.	0 ~ 1000 rpm	15 rpm	Programming	—
P2-13	010D	No-Flow Detection Time NF Detect Time	No-flow activates when the motor rpm remains within the programmed bandwidth (P2-12) for a time specified in parameter P2-13.	0.0 ~ 1000.0 s	5.0 s	Programming	—
P2-14	010E	No-Flow Stabilization Time NF StabilizeTime	Time delay when setpoint returns to the original setting after being changed for no-flow detection.	0.0 ~ 1000.0 s	5.0 s	Programming	—

◆ Denotes that parameter can be changed when the drive is running.

Parameter No.	Addr. Hex	Parameter Name Digital Operator Display	Description	Setting Range	Factory Setting	Menu Location	Page No.
P2-15	010F	No-Flow Delta Feedback Level NF FB Level	No-flow feedback (PID-Error: setpoint minus feedback) level used to detect no-flow condition based on feedback value. Delta feedback (setpoint minus feedback) has to exceed the programmed level for the time programmed in P2-17 to detect a no-flow condition.	0.0 ~ 6000.0 (system units P1-02)	1.0 (system units P1-02)	Programming	—
P2-16	011F	No-Flow Set-point Compensation NF SP Comp	Set-point compensation used in the no-flow detection function.	0.0 ~ 6000.0 (system units P1-02)	1.5 (system units P1-02)	Programming	—
P2-17	0120	No-Flow Feedback Delay Time NF Fdbk Delay Time	Delay timer used in combination with the no-flow feedback (PID-Error: setpoint minus feedback) level (P2-15) used to detect the no-flow condition based on the feedback value. Delta feedback (Set-point minus feedback) has to exceed the programmed level (P2-15) for the time programmed to detect a no-flow condition.	0.0 ~ 1000.0 s	2.0 s	Programming	—
P2-18	0121	No-Flow Motor RPM Sample Time NF RPM Sample Tm	No-flow detection motor rpm sample rate.	0.1 ~ 1000.0 s	2.0 s	Programming	—
P2-19	0122	No-Flow Feedback Detection Direction NF Fdbk Det Direct	Direction of feedback detection upon return of no-flow detection. 0: Outside Bandwidth (P2-15) 1: Inside Bandwidth (P2-15)	0 ~ 1	0	Programming	—
P2-20 ◆	0123	Alternative Sleep Activate Level SLP Act Level	When P2-01 Sleep Level Type is set for 0 (Output Frequency) or 3 (Output Speed), the sleep function becomes active when the output frequency is greater or equal to the level in P2-20. When programmed to 0, the sleep function will become active above the P2-02 Sleep Level. Level.Display Units for Sleep Activate Level P2-20 when P2-01 is programmed for the following:<0034> P2-01=0: Display based on “Hz” P2-01=1: Display based on “Hz” P2-01=2: Display based on “Hz” P2-01=3: Display based on “rpm” P2-01=4: Display based on “Hz” A value of 0 disables this function.	0.0 ~ 6000.0	0.0	Programming	—
P2-21 <0034>	820	Sleep Boost Level Sleep Boost Lvl	Sets the amount of boost applied to the setpoint just before going to sleep. A setting of 0.0 disables the sleep boost function. (Internally limited to 25 % of P1-03.)	0.0 ~ 6000.0 (system units P1-02)	0.0	Programming	
P2-22 <0034>	821	Sleep Boost Maximum Time Sleep Boost Time	Sets the amount of time the system (feedback) has to reach the “boosted” setpoint. If more than this time elapses, the drive will go to sleep	1.0 ~ 160.0 s	5.0 s	Programming	
P2-23 ◆ <0034>	822	Anti-No-Flow Bandwidth ANF Bandwidth	Sets the amount of PI “Error” bandwidth used to detect the no-flow condition. Operation can become less stable if this value is set too high. A setting of 0.00 % disables this feature.	0.00 ~ 2.00 %	0.40 %	Programming	
P2-24 ◆ <0034>	823	Anti-No-Flow Detection Time ANF Det Time	Sets the time delay after no-flow is detected before the drive starts its increased deceleration rate.	1.0 ~ 60.0 s	10.0 s	Programming	
P2-25 ◆ <0034>	824	Anti-No-Flow Release Level ANF Release Lvl	Once the Anti-No-Flow activates (after the P2-24 time), the feedback must drop this amount below the setpoint for the Anti-No-Flow to disengage and return to normal PI operation.	0.0 ~ 100.0 psi	3.0 psi	Programming	
◆ Denotes that parameter can be changed when the drive is running.							
Pump Multiplex							
P3-01	0614	Lead-Lag Control Lead-Lag Control	Selects lead-lag detection operation. 0: Output Frequency (Output Frequency). 0: Uses P3-02, P3-04, P3-06, P3-09, P3-10. 1: Feedback (Feedback Level). 1: Uses P3-03, P3-04, P3-05, P3-06. 2: Feedback + Fout (Feedback Level and Output Frequency). 2: Uses P3-02, P3-03, P3-05, P3-06, P3-07, P3-08, P3-10. Works in conjunction with parameters P2-11 to P2-19.	0 ~ 2	0	Programming	—

Parameter No.	Addr. Hex	Parameter Name Digital Operator Display	Description	Setting Range	Factory Setting	Menu Location	Page No.
P3-02 ◆	0615	Drive Multi / Maximum Level Max-Multi Level	<p>Sets the maximum level used for multiplex pumping operation. Parameter is active when P3-01 = 0 or P3-01 = 2 is selected.</p> <p>P3-01 = 0: When the output frequency rises above the level programmed in P3-02 for a time specified in P3-04, the next available pump will be added to the system by means of a multi-function digital output closure (H2-XX = 40, 41).</p> <p>P3-01 = 1: Not Used.</p> <p>P3-01 = 2: When the output frequency rises above level programmed in P3-02 and the delta feedback (setpoint minus feedback) has exceeded the level programmed in P3-03 for a time specified in P3-04, the next available pump will be added to the system by means of a multi-function digital output closure (H2-XX = 40, 41).</p>	0.0 ~ 120.00 Hz	59.0 Hz	Programming	—
P3-03 ◆	0616	Add Pump Delta Level Add Pump D-Lvl	<p>Sets the level used for multiplex pumping operation. The parameter is active when P3-01 = 1 or P3-01 = 2 is selected.</p> <p>P3-01 = 0: Not Used</p> <p>P3-01 = 1: When the delta feedback (setpoint minus feedback) has exceeded the level programmed in P3-03 for a time specified in P3-04, the next available pump will be added to the system by means of a multi-function digital output closure. (H2-XX = 40, 41).</p> <p>P3-01 = 2: When the output frequency rises above level programmed in P3-02 and the delta feedback (Set-point minus feedback) has exceeded the level programmed in P3-03 for a time specified in P3-04, the next available pump will be added to the system by means of a multi-function digital output closure. (H2-XX = 40, 41).</p> <p>Note: Do not program this level too close to the system setpoint or excessive cycling of the pump system may occur.</p>	0.0 ~ 6000.0 (system units P1-02)	0.0 (system units P1-02)	Programming	—
P3-04 ◆	0617	Add Pump Delay Time Add Pump Dly Tm	<p>Sets the delay time before a pump is added to the system. Works in conjunction with parameters P3-02, P3-03, and P2-11 to P2-19.</p>	0 ~ 3600 s	2 s	Programming	—
P3-05 ◆	0618	Shutdown Pump Delta Level Shdn Pump D-Lvl	<p>Sets the level used for multiplex pumping operation. Parameter is active when P3-01 = 1 or P3-01 = 2 is selected.</p> <p>P3-01 = 0: Not Used</p> <p>P3-01 = 1 : When the delta feedback (feedback minus setpoint) has exceeded the level programmed in P3-05 for a time specified in P3-06, the last pump that was brought online will be shutdown by means of a multi-function digital output opening. (H2-XX = 40, 41).</p> <p>P3-01 = 2: When the output frequency drops below level programmed in P3-09 or P3-10 (depends on last pump running) and the delta feedback (feedback minus setpoint) has exceeded the level programmed in P3-05 for a time specified in P3-06, the last pump that was brought online will be shutdown by means of a multi-function digital output opening. (H2-XX = 40, 41).</p> <p>Note: Do not program this level too close to the system setpoint or excessive cycling of the pump system may occur.</p>	0.0 ~ 6000.0 (system units P1-02)	0.0 (system units P1-02)	Programming	—
P3-06 ◆	0619	Shutdown Pump Delay Time Shdn Pump Dly Tm	<p>Sets the delay time before one of the additional across the line pumps is shutdown. Works in conjunction with parameters P3-02 and P3-03.</p>	0 ~ 3600 s	5 s	Programming	—
P3-07 ◆	061A	Multi Pump Set-point Increase MP Set-point Incr	<p>Sets the amount the drive's setpoint will decrease for each time a new pump is brought offline.</p> <p>Pump 1: Set-point Pump 1+2: Set-point + P3-07 Pump 1+2+3: Set-point + (2 x P3-07)</p>	0.0 ~ 6000.0 (system units P1-02)	0.0 (system units P1-02)	Programming	—
P3-08 ◆	061B	Multi Pump Set-point Decrease MP Set-point Decr	<p>Sets the amount the drive's setpoint will increase for each time a new pump is brought online.</p> <p>Pump 1: Set-point Pump 1+2: Set-point - P3-08 Pump 1+2+3: Set-point - (2 x P3-08)</p>	0.0 ~ 6000.0 (system units P1-02)	0.0 (system units P1-02)	Programming	—

◆ Denotes that parameter can be changed when the drive is running.

Parameter No.	Addr. Hex	Parameter Name Digital Operator Display	Description	Setting Range	Factory Setting	Menu Location	Page No.
P3-09 ◆	061C	Pump 2 Frequency Shutdown Level P2 Freq Shd Lvl	<p>Sets the level used for multiplex pumping operation. Parameter is active when P3-01 = 0 or P3-01 = 2 is selected.</p> <p>P3-01 = 0: When the output frequency falls below the level programmed in P3-09 for a time specified in P3-06 and a total of 2 pumps are running, the last pump (Pump 2) that was brought online will be shutdown by means of a multi-function digital output opening (H2-XX = 40, 41).</p> <p>P3-01 = 1: Not Used</p> <p>P3-01 = 2: When the output frequency falls below the level programmed in P3-09 and a total of 2 pumps are running and the delta feedback (feedback minus setpoint) has exceeded the level programmed in P3-05 for a time specified in P3-06, the last pump (Pump 2) that was brought online will be shutdown by means of a multi-function digital output opening (H2-XX = 40, 41).</p>	0.0 ~ 120.0 Hz	40.0 Hz	Programming	—
P3-10 ◆	061D	Pump 3 Frequency Shutdown Level P3 Freq Shd Lvl	<p>Sets the level used for multiplex pumping operation. Parameter is active when P3-01 = 0 or P3-01 = 2 is selected.</p> <p>P3-01 = 0: When the output frequency falls below the level programmed in P3-10 for a time specified in P3-06 and a total of 3 pumps are running, the last pump (Pump 3) that was brought online will be shutdown by means of a multi-function digital output opening (H2-XX = 40, 41).</p> <p>P3-01 = 1: Not Used</p> <p>P3-01 = 2: When the output frequency falls below the level programmed in P3-10 and a total of 3 pumps are running and the delta feedback (feedback minus setpoint) has exceeded the level programmed in P3-05 for a time specified in P3-06, the last pump (Pump 3) that was brought online will be shutdown by means of a multi-function digital output opening (H2-XX = 40, 41).</p>	0.0 ~ 120.0 Hz	40.0 Hz	Programming	—
P3-11 ◆	0110	Multiplex Stabilization Time M-Stabilize Time	<p>Sets the time used to stabilize system when a pump is added (brought online) or shutdown during multiplex operation. When a pump is added, the stabilize timer temporarily disables the lead / lag functionality for the programmed time to prevent pump cycling.</p> <p>Note: This function only active in the multiplex mode when P1-01 is greater than 0. During the stabilization time, the pump protection and lead-lag control is suspended.</p>	0 ~ 3600 s	2 s	Programming	—
P3-12 ◆	0111	Delta Set-point Feedback Acc / Dec Changeover SP ACC/DEC Hyst.	<p>Sets the level when the acceleration and deceleration times change over to the values programmed in C1-05 and C1-06 respectively. This function will activate when the difference between the delta setpoint and feedback are within the level programmed in P3-12. This function is used to improve the pump regulation. A value of 0 disables this function.</p>	0.0 ~ 6000.0 (system units P1-02)	0.0 (system units P1-02)	Programming	—
P3-13 ◆	0112	Friction Compensation start Frequency Fric. Comp Lvl	<p>Sets the level when the setpoint will be adjusted to compensate for the friction losses. This function will activate when the output frequency rises above the level programmed in P3-13. The maximum compensation at maximum output frequency (E1-04) is specified by maximum setpoint frequency (P2-10).</p> <p>Note: This function is only active in simplex mode when P1-01 = 0.</p>	0.0 ~ 120.0 Hz	0.0 Hz	Programming	—
P3-14 ◆	0113	Maximum Friction Increase at Maximum Frequency Friction Inc	<p>Sets the maximum setpoint friction compensation at maximum output frequency (E1-04). This function is a linear calculation with P3-13 as its starting frequency. Example: P3-13 = 30.0 Hz, P3-14 = 10.0 psi, output frequency = 45.0 Hz and maximum frequency = 60.0 Hz Set-point Increase = (45-30 Hz) x 10 psi / (60 Hz – 30 Hz) ≥ 5.0 psi</p> <p>Note: This function is only active in simplex mode when P1-01 = 0.</p>	0.0 ~ 6000.0 (system units P1-02)	0.0 (system units P1-02)	Programming	—

◆ Denotes that parameter can be changed when the drive is running.

Parameter No.	Addr. Hex	Parameter Name Digital Operator Display	Description	Setting Range	Factory Setting	Menu Location	Page No.
Pump Advanced							
P4-01 ◆	0115	Pre-charge Level Pre-charge Level	Sets the level when the drive will run at the pre-charge frequency (P4-02). The drive will stop when one of the following conditions occurs: Feedback signal rises above P4-01 level, pre-charge timer P4-03 expires, or low water digital input is deactivated (H1-XX = 85). The pre-charge function can only be activated while in a stop condition. The function is enabled by setting P4-03 to a value greater than 0. When the function is activated, the drive's operator display indicates a "Pre-charge" alarm. Note: This function is only active in the stopped mode. If P1-01 = 3, the function is active when there is only one drive running on the network.<0034> Thrust Mode: The pre-charge level is used when the thrust mode is active for the feedback check. The thrust mode is deactivated when the feedback exceeds the programmed level in P4-01. A value of 0 disables the thrust mode feedback check function.	0.0 ~ 6000.0 (system units P1-02)	0.0 (system units P1-02)	Programming	—
P4-02 ◆	0116	Pre-charge Frequency Pre-charge Freq	Sets the frequency reference used when the pre-charge function is active.	0.00 ~ 120.00 Hz	0.00 Hz	Programming	—
P4-03 ◆	0117	Pre-charge Time Pre-charge Time	Sets the maximum allowed pre-charge time. A value of 0 disables this function. If P1-01 = 3, the function is active when there is only one drive running on the network.<0034>	0.0 ~ 3600.0 min	0.0 min	Programming	—
P4-04 ◆	0118	Thrust Bearing Acceleration Time Thrust Acce Time	Sets the thrust bearing acceleration time. When enabled (P4-05 > 0), the drive output frequency will ramp up to the specified thrust bearing frequency reference in P4-05 using an acceleration time as specified in P4-04. The PI mode is automatically disabled. Once the output frequency reaches the programmed thrust bearing frequency, the drive automatically switches to PI control and the original acceleration time (C1-01), and will continue in the normal operation (auto) mode, unless Pre-charge is enabled, in which case Pre-charge mode occurs. This function active in the Hand Mode and Auto Mode. Note: In Auto Mode , the Minimum Pump Frequency will become the thrust bearing frequency if smaller than the thrust bearing frequency in P4-05. In Hand Mode , the minimum frequency is P4-05 when the thrust mode is enabled. The Pre-charge level is not active in the hand mode.	0.0 ~ 600.0 s	1.0 s	Programming	—
P4-05 ◆	0119	Thrust Bearing Frequency Thrust Freq	Sets the frequency reference used when the thrust bearing function is active. A value of 0 disables this function.	0.0 ~ 120.0 Hz	30.0 Hz	Programming	—
P4-06 ◆ <0032>	011A	Thrust Bearing Deceleration Time Thrust Dec Time	This deceleration time will be used to bring the drive from Thrust Frequency (P4-05) to stop when Thrust Mode is active. Any time the Run Command is removed while the drive is operating in the Thrust Mode above the Thrust Frequency, this deceleration time will be used once the frequency reference is at or below the Thrust Frequency. Note: In Auto Mode , the Minimum Pump Frequency (P1-06) will become the thrust bearing frequency if smaller than the thrust bearing frequency in P4-05. In Hand Mode , the minimum frequency is P4-05 when the thrust mode is enabled. The Pre-charge level is not active in the hand mode.	0.0 ~ 600.0 s	1.0 s	Programming	—
P4-07 <0032>	011B	Feedback Fault Auto Restart Enable Fdback Flt Rstrt	Setting to enable / disable Auto Restart for the following iQpump transducer / feedback faults (N = disable / Y = enable): LL: Low Level Feedback (P1-07) HL: High Level Feedback (P1-09) TL: Transducer Loss (b5-12) 0: TL = N HL = N LL = N 1: TL = N HL = N LL = Y 2: TL = N HL = Y LL = N 3: TL = N HL = Y LL = Y 4: TL = Y HL = N LL = N 5: TL = Y HL = N LL = Y 6: TL = Y HL = Y LL = N 7: TL = Y HL = Y LL = Y Note: Parameter L5-01 needs to be set to "1" and program L5-03 needs to be set to the applicable time.	0 ~ 7	0	Programming	—

◆ Denotes that parameter can be changed when the drive is running.

Parameter No.	Addr. Hex	Parameter Name Digital Operator Display	Description	Setting Range	Factory Setting	Menu Location	Page No.
P4-08 <0032>	011C	Protection Fault Auto Restart Enable Prot Flt Restrt	Setting to enable / disable Auto Restart for the following iQpump protection faults (N = disable / Y = enable): SP: Not Maintaining SetPoint (P1-11) LOP: Loss of Prime (P1-16) POC: Pump Over Cycling (P2-08)) 0: POC = N LOP = N SP = N 1: POC = N LOP = N SP = Y 2: POC = N LOP = Y SP = N 3: POC = N LOP = Y SP = Y 4: POC = Y LOP = N SP = N 5: POC = Y LOP = N SP = Y 6: POC = Y LOP = Y SP = N 7: POC = Y LOP = Y SP = Y Note: Parameter L5-01 needs to be set to “1” and program L5-03 needs to be set to the applicable time.	0 ~ 7	0	Programming	—
P4-09 <0032>	011D	Loss of Prime Maximum Restart Time After Fault LOP Max Rstrt T	If the restart fails (or is not attempted due to a continuing fault condition) the drive waits this many minutes before attempting another restart. Note: This parameter will take the place of L5-03 during a Loss of Prime Fault restart attempt.	0.2 ~ 6000.0 min	0.2 min	Programming	—
P4-10 ◆	011E	Auto Mode Operator Run Power Down Storage. AMO PwDn-Storage	Stores the run status in the Auto mode when operating from digital operator (b1-02 = 0). 0: Disabled. 1: Enabled. <div style="text-align: center;"> WARNING</div> When the drive is powered down while running, then upon power-up it will automatically initiate an internal run command.	0 ~ 1	0	Pump Quick Setup	—
P4-11 ◆ <0034>	82A	Utility Start Delay Utility Delay	Sets the amount of time the drive will delay starting if a run command is present at power up. A setting of 0.0 disables this function. If P1-01 = 3, the drive is unavailable to the network (Pump Off Network) when the function is active. <0034>	0.0 ~ 1000.0 min	0.2 min	Programming	
P4-12 ◆ <0034>	82B	Pre-charge Frequency 2 Pre-charge Freq2	Frequency reference used when Pre-charge 2 function is active. A value of 0.00 disables this function.	0.00 ~ 120.00 Hz	0.00 Hz	Programming	
P4-13 ◆ <0034>	82C	Pre-charge Time 2 Pre-charge Time2	Time at which the drive will spend at the Pre-charge Frequency 2 (P4-12) speed during pre-charge. A value of 0.0 disables this function.	0 ~ 3600.0 min	0.0 min	Programming	
P4-14 <0034>	82D	Two Motor Alternation Selection Mot 2 Alternate	Selects if the alternation feature is enabled. 0: Disabled 1: Enabled 2: Motor 1 Only 3: Motor 2 Only	0 ~ 3	0	Programming	
P4-15 <0034>	82E	Alternation Operation Selection Alternation Oper	Selects the drive behavior when the internal alternation timer expires. 0: Wait For Stop 1: Immediate	0 ~ 1	0	Programming	
P4-16 <0034>	82F	Alternation Time Alternation Time	Selects the amount of time each motor will run before the drive switches to the other motor.	1.0 ~ 100.0 hr	24.0 hr	Programming	
P4-17 <0034>	830	Dual Zone PID Feedback Bandwidth Range Dual Zone Range	Determines the detection bandwidth for the dual zone PI control.	0 ~ 6000.0 (system units P1-02)	10.0 (system units P1-02)	Programming	
P4-18 ◆ <0034>	831	Run-Stop Control Run Time R-S Run Time	This parameter sets the amount of time the drive will run for when the run-stop control is enabled. It will also set the “timed” run time when enabled (b1-02 = 5).	0.0 ~ 6000.0 min	0.0 min	Programming	
P4-19 ◆ <0034>	832	Run-Stop Control Stop Time R-S Stop Time	This parameter sets the amount of time the drive will stop for when the run-stop control is enabled.	0.0 ~ 6000.0 min	0.0 min	Programming	
P4-20 ◆ <0034>	833	Run-Stop Control Cycles R-S Cycle Count	This parameter determines how many run-stop cycles the drive will execute before staying stopped.	0 ~ 1000	0	Programming	

◆ Denotes that parameter can be changed when the drive is running.

Parameter No.	Addr. Hex	Parameter Name Digital Operator Display	Description	Setting Range	Factory Setting	Menu Location	Page No.
P4-21 <0034>	834	Low City Pressure Input Select Low City In Sel	Selects the type of pressure switch connected to the “Low City Pressure” digital input (H1-0x = 73). 0: Normally Open (closed indicates the “Low City Pressure” condition) 1: Normally Closed (open indicates the “Low City Pressure” condition)	0 ~ 1	1	Programming	
P4-22 ◆ <0034>	835	Low City Pressure Input Delay Low City Delay	Sets the amount of time a “Low City Pressure” condition needs to be present before the drives will stop. Also sets the amount of time that the pressure needs to be adequate before the drive system will re-start.	1 ~ 1000 s	10 s	Programming	
P4-23 ◆ <0034>	836	Lube Pump Delay Timer Lube Pump Time	Sets the amount of time the drive’s output will be delayed and the Lube Pump digital output (H2-0x = 55) will be energized. A setting of zero will disable this feature.	0.0 ~ 300.0 s	0.0 s	Programming	
Hand Mode							
P5-01 ◆	0124	Hand Mode Reference Source Hand Mode Ref	Sets the hand mode reference source. 0: Analog Input A1 (0-10 V) 1: Hand reference (P5-02)	0 ~ 1	1	Programming	—
P5-02 ◆	0125	Hand Reference Hand Reference	Sets the frequency reference used when the hand mode is active and P5-01 is programmed to 1.	0.00 ~ 120.00 Hz	40.00 Hz	Programming	—
P5-03 <0032>	0114	HAND / AUTO During Run Selection HAND/AUTO @Run	Selects if the drive will permit switching between HAND and AUTO modes while running. 0: Disabled 1: Enabled Switching from HAND to AUTO is not permitted when the drive output frequency is less than the PID minimum speed. Switching from AUTO to HAND is not permitted when the drive is running in the multiplex mode with auxiliary drives enabled.	0 ~ 1	0	Programming	—
P5-04 <0032>	0513	Hand Key Function Selection Oper HAND Key	Enables or disables the “HAND” key on the digital operator. 0: Disabled 1: Enabled	0 ~ 1	1	Pump Quick Setup	—
Flow Meter Setup							
P6-01 <0034>	840	Flow Meter Scaling Flow Meter Scale	Sets the scaling for the flow meter connected to Terminal A1. Enter the gal / min when the flow meter is at it’s rated output. A setting of 0.0 disables all flow meter functions.	0.0 ~ 6000.0 Gpm	0.0 Gpm	Programming	
P6-02 <0034>	841	Water Flow Units Water Flow Units	Sets the units displayed for monitor U1-95. Also sets units for parameters P2-02 and P6-04. 0: U.S. Gallons / min (GPM) 1: U.S. Gallons / hr (GPH) 2: U.S. Barrels / min (BPM) 3: U.S. Barrels / hr (BPH) 4: U.S. Barrels / Day (BPD)	0 ~ 4	0	Programming	
P6-03 ◆ <0034>	842	Flow Accumulation Reset Flow Accum Reset	Resets the accumulated flow and returns the monitors U1-96 and U1-97 to zero. 0: No Reset 7770: Reset Accum All other settings will have no effect. Note: After this parameter is changed it will automatically return to a “0”.	0 ~ 65535	0	Programming	
P6-04 ◆ <0034>	843	Low Flow Level Low Flow Level	If the drive is running and the flow goes below this level for more than the P6-05 time, a Low Flow fault or alarm will occur. A setting of 0 disables the low flow detection. If P1-03 = 3, a LOWFL fault will stop all drives running on the network.	0.0 ~ 6000.0 (*n1)	0.0	Programming	
P6-05 ◆ <0034>	844	Low Flow Detection Delay Time When Already Running Low Flow Tim Run	Sets the amount of time the flow rate must be below the P6-04 level before a Low Flow condition is detected.	0 ~ 6000 s	10 s	Programming	
P6-06 ◆ <0034>	845	Low Flow Detection Wait Time At Start Low Flow Time St	Sets the time the drive will wait after coming out of a zero speed condition before activating Low Flow detection.	0.0 ~ 3600.0 min	0.0 min	Programming	

(*n1) Displayed units are determined by parameter P6-02.

◆ Denotes that parameter can be changed when the drive is running.

Parameter No.	Addr. Hex	Parameter Name Digital Operator Display	Description	Setting Range	Factory Setting	Menu Location	Page No.
P6-07 <0034>	846	Low Flow Select Low Flow Sel	Sets the behavior of the drive when a “Low Flow” condition is detected. 0: No Display 1: Alarm Only 2: Fault 3: Auto-Restart (time set by P6-08)	0 ~ 3	1	Programming	
P6-08 <0034>	847	Low Flow Auto-Restart Time Low Flow Rstrt	Sets the amount of time the drive will wait before attempting an auto-restart of the “Low Flow” fault. Effective only when P6-07 = 3.	0.1 ~ 6000.0 min	3.0 min	Programming	
P6-09 ◆ <0034>	848	Accumulation Level Fine Accum Lvl Fine	Sets the accumulated volume that will trigger the Accum Level alarm. Accum Level fault, or Accum Level digital output. Total Accum Level can be calculated as follows: Total Accum Level = P6-10 x 1000 + P6-09. If P1-01 = 3, an ACCUM fault will stop all drives running on the network.	0.0 ~ 999.0 gal	0.0 gal	Programming	
P6-10 ◆ <0034>	849	Accumulation Level Course Accum Lvl Course	Sets the accumulated volume that will trigger the Accum Level alarm. Accum Level fault, or Accum Level digital output. Total Accum Level can be calculated as follows: Total Accum Level = P6-10 x 1000 + P6-09. If P1-01 = 3, an ACCUM fault will stop all drives running on the network.	0 ~ 61036 kgl	0 kgl	Programming	
P6-11 ◆ <0034>	84A	Accumulation Behavior Accum Behavior	Sets how the drive will respond when the accumulated volume reaches the P6-09 and P6-10 level. 0: No Display 1: Alarm Only 2: Fault 3: Fault - Auto Flow Accum Reset	0 ~ 3	1	Programming	
P6-12 ◆ <0034>	84B	High Flow Level High Flow Level	If the drive is running and the flow goes above this level for more than the P6-13 time, a High Flow fault or alarm will occur. A setting of 0 disables the High Flow detection. If P1-01 = 3, a HIFLO fault will stop all drives running on the network.	0.0 ~ 6000.0 (*n1)	0.0	Programming	
P6-13 ◆ <0034>	84C	High Flow Detection Delay Time High Flow Time	Sets the amount of time the flow rate must be above the P6-12 level before a High Flow condition is detected.	1 ~ 6000 s	10 s	Programming	
P6-14 <0034>	84D	High Flow Select High Flow Sel	Sets the behavior of the drive when a “High Flow” condition is detected. 0: No Display 1: Alarm Only 2: Fault 3: Auto-Restart (time set by L5-03)	0 ~ 3	1	Programming	

(*n1) Displayed units are determined by parameter P6-02.

Anti-Jam/De-Scale							
P7-01 <0034>	84F	Anti-Jam / De-Scale Operation Selection Anti-Jam/De-Scale	Selects if the Anti-Jam or De-Scale functions are enabled. 0: Disabled 1: Anti-Jam Enabled 2: De-Scale Enabled. 3: Force De-Scale	0 ~ 3	0	Programming	
P7-02 ◆ <0034>	850	Anti-Jam / De-Scale Cycle Count A-J Cycle Count	This parameter sets the maximum number of cycles attempted before the Anti-Jam fault occurs and also sets the number of fwd / rev cycles for the De-Scale function.	1 ~ 100	1	Programming	
P7-03 ◆ <0034>	851	Anti-Jam Detection Current Level A-J Detection Level	Sets the current level (at start) that will trigger the Anti-Jam function. Set as a percentage of motor rated current.	50 ~ 200 %	120 %	Programming	
P7-04 ◆ <0034>	852	Anti-Jam Detection Time A-J Det. Time	Sets the amount of time the current has to be above the P7-03 level to trigger the Anti-Jam function.	0.1 ~ 2.0 s	0.3 s	Programming	
P7-05 ◆ <0034>	853	Anti-Jam / De-Scale Frequency Reference AJ/De-Scale Freq	Sets the speed during the De-Scale operation and during reverse operation of the Anti-Jam function.	0.00 ~ 120.00 Hz	25.00 Hz	Programming	
P7-06 ◆ <0034>	854	De-Scale Forward Run Time De-Scale Fwd Run	Sets the amount of time the drive will run in the forward time each cycle during the De-Scale function.	1 ~ 6000 s	10 s	Programming	
P7-07 ◆ <0034>	855	De-Scale Reverse Run Time De-Scale Rev Run	Sets the amount of time the drive will run in the reverse time each cycle during the De-Scale function.	1 ~ 6000 s	10 s	Programming	

◆ Denotes that parameter can be changed when the drive is running.

Parameter No.	Addr. Hex	Parameter Name Digital Operator Display	Description	Setting Range	Factory Setting	Menu Location	Page No.
P7-08 ◆ <0034>	856	De-Scale Acceleration Time De-Scale Accel	Sets the amount of time it will take the drive to accelerate from zero to the De-Scale frequency reference P7-05 (internally limited 0.1 ~ 6000.0 s).	0.0 ~ 600.0 s	2.0 s	Programming	
P7-09 ◆ <0034>	857	De-Scale Deceleration Time De-Scale Decel	Sets the amount of time it will take the drive to decelerate from the De-Scale frequency reference P7-05 to zero (internally limited 0.1 ~ 6000.0 s).	0.0 ~ 600.0 s	2.0 s	Programming	
P7-10 ◆ <0034>	858	De-Scale Pump Run Time De-Scale Time	Sets the number of pump operating hours (pump speed > 0) before a De-Scale routine will run.	1.0 ~ 2000.0 hr	168.0 hr	Programming	
P7-11 ◆ <0034>	859	Anti-Jam Release Time Anti-Jam Release	Sets the amount of time that the current must be below the P7-03 level in order to resume normal operation.	0.5 ~ 10.0 s	2.0 s	Programming	
Pressure and Level Control							
P8-01 <0034>	860	Pressure and Level Control Select Pres&Lvl Control	Enables / Disables the Constant Pressure With Well Draw Down Control. 0: Disabled 1: Enabled	0 ~ 1	0	Programming	
P8-02 <0034>	861	Water Level Scaling Water Lvl Scale	Sets the full scale (20 mA) output of the pressure transducer that is connected to Terminal A1.	5 ~ 500 psi	100 psi	Programming	
P8-03 ◆ <0034>	862	Water Level Set-point Water Lvl Setpnt	Sets the amount of water above the sensor that the drive will attempt to regulate to.	0.0 ~ 1200.0 ft	20.0 ft	Programming	
P8-04 ◆ <0034>	863	Minimum Water Level Min Water Level	When the amount of water above the sensor drops below this level for more than the P2-03 time, the drive will go to sleep.		10.0 ft	Programming	
P8-05 ◆ <0034>	864	Wake-Up Water Level Wake-Up Level	If the drive has been forced to sleep based upon the minimum water level (P8-04), the water will have to go above this level for more than the P1-05 time in order to wake up.		30.0 ft	Programming	
P8-06 ◆ <0034>	865	Level Control Minimum Speed Level Min Spd	This parameter sets the minimum speed the drive will be allowed to run at when the drive is controlling the water level. When the drive is controlling pressure or this parameter is set less than P1-06 and P4-05, P1-06 and P4-05 will be used as the minimum speed.	0.00 ~ 120.00 Hz	0.00 Hz	Programming	
P8-07 ◆ <0034>	866	Low Level Detection Level Low Level Detection	When the amount of water above the sensor drops below the level for more than the P8-08 time, the drive will respond depending on the P8-09 setting. A setting of 0.0 disables this detection.	0.0 ~ 1200.0 ft	0.0 ft	Programming	
P8-08 ◆ <0034>	867	Low Level Detection Time Delay Low Lvl Det Tm	Sets the amount of time delay that the water level must drop below the P8-07 level before the drive will react.	0.0 ~ 300.0 min	0.1 min	Programming	
P8-09 <0034>	868	Low Level Behavior Low Lvl Behavior	Sets how the drive will respond when the water level in the well drops below the P8-07 level for more than the P8-08 time. 0: No Display (Digital Output Only) 1: Alarm Only 2: Fault	0 ~ 2	1	Programming	
P8-10 ◆ <0034>	869	Level Control Proportional Gain Lvl Ctrl P Gain	Sets the proportional gain for the water level control.	0.00 ~ 25.00	2.00	Programming	
P8-11 ◆ <0034>	86A	Level Control Integral Time Lvl Ctrl I Time	Sets the integral time for the water level control. A setting of zero disables the water level control integrator.	0.0 ~ 360.0 s	5.0 s	Programming	
Network Options							
P9-01 <0034>	0880	Lead Drive Selection Lead Drive Sel	Specifies how the next Lead Drive is selected. 0: Next Available 1: Lowest Runtime	0 ~ 1	1	Programming	
P9-02 <0034>	0881	Feedback Source Feedback Source	Defines which signal to use for PI Feedback when P1-01 = 3. 0: Analog Only 1: Ana->Net, No Alarm. 2: Ana->Net, Alarm 3: Network Only Setting has no effect when P1-01 = 3.	0 ~ 3	0	Programming	
P9-03 ◆ <0034>	0882	Alternation Time Alternation Time	Specifies the time for a drive to request alternation, influenced by the Alternation Mode P9-04. The alternation feature is disabled when this parameter is set to 0.	0 ~ 1000 hr	24 hr	Programming	

◆ Denotes that parameter can be changed when the drive is running.

Parameter No.	Addr. Hex	Parameter Name Digital Operator Display	Description	Setting Range	Factory Setting	Menu Location	Page No.
P9-04 <0034>	0883	Alternation Mode Alternation Mode	Determines how alternation is performed: 0: FIFO Auto 1: FIFO Forced 2: LIFO	0 ~ 2	0	Programming	
P9-05 <0034>	0884	Lag Drive Mode Lag Drive Mode	Determines how the lag drives function. 0: Fixed Speed - Runs at the P9-06 setting. 1: PI Regulation - Uses PI to determine speed.	0 ~ 1	0	Programming	
P9-06 ◆ <0034>	0885	Lag Fixed Speed Lag Fixed Speed	When the drive changes from a lead to a lag and P9-05 = 0, the drive will run at this speed after P9-07 delay time expires.	0.0 ~ 120.0 Hz	55.0 Hz	Programming	
P9-07 ◆ <0034>	0886	Lag Fixed Speed Delay Lag Fixed Spd Dly	When the drive changes from a lead to a lag and P9-05 = 0, this time specifies how long before the drive runs at the P9-06 speed.	0 ~ 1000 s	5 s	Programming	
P9-08 <0034>	0887	Add Pump Mode Add Pump Mode	Selects the detection method for staging a new pump: 0: Output Frequency 1: Feedback 2: Feedback + Fout	0 ~ 2	0	Programming	
P9-09 ◆ <0034>	0888	Add Freq Level Add Freq Lvl	When P9-08 = 0 and the output frequency rises above this level for the time set in P9-11, the lead drive will request for a new lead drive through the iQpump Memobus Network. When P9-08 = 2 and the output frequency rises above this level the delta feedback (setpoint - feedback) has exceeded the level set in P9-10 for the time set in P9-11, the lead drive will request for a new lead drive through the iQpump Memobus network.	0.0 ~ 120.0 Hz	56.0 Hz	Programming	
P9-10 ◆ <0034>	0889	Add Delta Level Add Delta Lvl	When P9-08 = 1 and the delta feedback (setpoint - feedback) has exceeded this level for the time set in P9-11, the lead drive will request for a new lead drive through the iQpump Memobus Network. When P9-08 = 2 and the delta feedback (setpoint - feedback) has exceeded this level and the output frequency is above P9-09 for the time set in P9-11, the lead drive will request for a new lead drive through the iQpump Memobus network.	0 ~ 6000.0 (system units P1-02)	0.0 (system units P1-02)	Programming	
P9-11 ◆ <0034>	088A	Add Delay Time Add Dly Time	Delay time before a new lead drive is added to the system.	0 ~ 3600 s	10 s	Programming	
P9-12 <0034>	088B	Remove Pump Mode Remove Pump Mode	Selects the detection method for de-staging to the previous lead pump: 0: Output Frequency 1: Feedback 2: Feedback + Fout	0 ~ 2	0	Programming	
P9-13 ◆ <0034>	088C	Remove Freq Level Remove Freq Lvl	When P9-12 = 0 and the output frequency drops below this level for the time set in P9-15, the lead drive will request to be removed from the system through the iQpump Memobus network. When P9-12 = 2 and the output frequency drops below this level and the delta feedback (feedback - setpoint) has exceeded the level set in P9-14 for the time set in P9-15, the lead drive will request to be removed from the system through the iQpump Memobus network.	0.0 ~ 120.0 Hz	40.0 Hz	Programming	
P9-14 ◆ <0034><0034> 4	088D	Remove Delta Level Remove Delta Lvl	When P9-12 = 1 and the delta feedback (feedback - setpoint) has exceeded this level for the time set in P9-15, the lead drive will request to be removed from the system through the iQpump Memobus network. When P9-12 = 2 and the delta feedback (feedback - setpoint) has exceeded this level and the output frequency is below P9-13 for the time set in P9-15, the lead drive will request to be removed from the system through the iQpump Memobus network.	0 ~ 6000.0 (system units P1-02)	0.0 (system units P1-02)	Programming	
P9-15 ◆ <0034>	088E	Remove Delay Time Remove Dly Time	Delay time before the lead drive is removed from the system.	0 ~ 3600 s	10 s	Programming	
P9-16 ◆ <0034>	088F	Stabilization Time Stabilization Time	Time used to stabilize the system when a pump is staged or de-staged. Lead-lag control and pump protection is suspended during this time.	0 ~ 3600 s	3 s	Programming	

◆ Denotes that parameter can be changed when the drive is running.

Parameter No.	Addr. Hex	Parameter Name Digital Operator Display	Description	Setting Range	Factory Setting	Menu Location	Page No.
P9-17 ◆ <0034>	0890	Setpoint Modifier Set-pt Modifier	System Set-point is incremented with this value depending on the number of pumps running. Pump 1: Set-point Pump X: Set-point + {(X-1) (P9-17)}	-6000.0 ~ 6000.0 (system units P1-02)	0.0 (system units P1-02)	Programming	
P9-18 ◆ <0034>	0891	High Feedback Quick De-Stage High FB De-stage	Determines the feedback level to trigger a quick de-stage, set as a percentage of parameter P1-09. The quick de-stage ignores parameters P9-12 to P9-15 and only uses an internal 2 second delay.	0.0 ~ 100.0 %	90.0 %	Programming	
P9-19 ◆	0892	Alternation Unit Alternation Unit	Selects the unit for P9-03 0: Hours (hr) 1: Minutes (min)	0 ~ 1	0	Programming	
P9-20	0893	Allow Network Run Allow Net Run	Specifies when a network run command is allowed: 0: Always 1: First / Alternation 2: First Only 3: Alternation Only	0 ~ 3	0	Programming	
P9-21 ◆	0894	Run Priority Run Priority	Sets the Lead Drive selection priority overriding the P9-01 selection. If multiple drives have the lowest P9-21 value, then P9-01 determines which drive becomes the Lead.	1 ~ 16	8	Programming	
P9-22 ◆ <0034>	0895	System Fault Retry System Flt Retry	Determines the number of times the iQpump Memobus Network will allow automatic restarts of system faults. The drive uses parameter L5-03 in determining when to attempt a system fault restart. For proper operation, this parameter should be set the same for all network drives.	0 ~ 10	5	Programming	
P9-23 ◆ <0034>	0896	Max Number of Running Pumps MaxPumps Running	Limits the maximum number of pumps that can run on the system.	1 ~ 16	16	Programming	
P9-24 ◆ <0034>	0897	Lead Swap @ Sleep Lead Swap @ Sleep	When the Lead DRive has been in Sleep for this amount of time and there is another drive available with a lower P9-21, then this drive will request for a swap. A setting of 0 disables this function.	0 ~ 7200 s	0 s	Programming	
P9-25 <0034>	0898	Highest Node Address Highest Node Adr	Defines the highest possible node address in the Memobus network. To yield optimal network performance, it is recommended to set the serial communication address H5-01 starting from 01h and then consecutively up to the last drive and then setting this parameter to that H5-01 address.	02 h ~ 10 h	08 h	Programming	
P9-26 <0034>	0899	Master Time-Out Master Time-Out	Sets the minimum amount of time that the slave drives will wait for a message from the master before performing the action set in P9-27.	3.0 ~ 10.0 s	4.0 s	Programming	
P9-27 <0034>	089A	Network Recovery Network Recovery	When no messages are received from the master for the time set in P9-26, the slave drive will act according to this setting: 0: Automatic - drive will attempt to assume master functionality. 1: Slave / Resume - drive will continue running when the master is lost and will wait for a master to come on-line. 2: Slave / Stop - drive will stop running when the master is lost and will wait for a master to come on-line. 3: Fault MSL - fault the drive with an MSL (Master Lost).	0 ~ 3	0	Programming	
P9-28 <0034>	089B	NETSCAN Alarm Time NETSCAN Alm Time	Sets the amount of time that the slave drives will wait for a message from the master before displaying a NETSCAN alarm.	1.0 ~ 10.0 s	2.0 s	Programming	
P9-29 ◆ <0034>	089C	Net Start Delay Net Start Delay	After the first drive on the network has been put on Auto mode, the network will wait this amount of time before selecting and starting the Lead Drive.	0.0 ~ 60.0 s	2.0 s	Programming	
Auto-Tuning							
T1-02	0702	Motor Rated Power Mtr Rated Power	Sets the motor rated power in kW. Note: T1-02 should be left at the default value (last 3 digits of the drive model number).	0.00 ~ 650.0	kVA Dependent	Auto-Tuning	135
T1-04	0704	Motor Rated Current Rated Current	Sets the motor rated current. (Used only during an auto-tune.)	kVA Dependent	kVA Dependent	Auto-Tuning	135

◆ Denotes that parameter can be changed when the drive is running.

Monitor List

Table 2 Monitor List

Parameter No.	Addr. Hex	Parameter Name Digital Operator Display	Description
			Monitor
U1-01	0040	Auto Set-point Reference Auto: Set-point	Auto Set-point Reference (speed command) monitor when in auto mode, frequency reference (speed command) setting location when in hand mode. Units changeable via P1-02.
U1-02	0041	Output Frequency Output Freq	Output frequency monitor in Hz.
U1-03	0042	Output Current Output Current	Output current monitor.
U1-06	0045	Output Voltage Output Voltage	Displays drive output voltage.
U1-07	0046	DC Bus Voltage DC Bus Voltage	Displays DC bus voltage.
U1-08	0047	Output Power Output kWatts	Displays drive output power.
U1-10	0049	Input Terminal Status Input Term Sts	<p>Displays drive input terminal status.</p>
U1-11	004A	Output Terminal Status Output Term Sts	<p>Output terminal ON / OFF check.</p>
U1-12	004B	Drive Operation Status Int Ctl Sts 1	
U1-13	004C	Cumulative Operation Time Elapsed Time	Displays total operating or power-on time of the drive.
U1-14	004D	Software Number FLASH ID	Displays drive's software number.
U1-15	004E	Terminal A1 Input Voltage Term A1 Level	Displays the input voltage on Terminal A1, as a percentage of 10 Vdc.

Parameter No.	Addr. Hex	Parameter Name Digital Operator Display	Description
Monitor			
U1-16	004F	Terminal A2 Input Voltage Term A2 level	Displays the input current (or voltage) on Terminal A2, as a percentage of 20 mA (or 10 Vdc).
U1-18	0051	Motor Secondary Current (Iq) Mot SEC Current	Displays the amount of current being used by the motor to produce torque (Iq).
U1-20	0053	Output Frequency After Soft Start SFS Output	Displays the frequency reference (speed command) after the accel and decel ramps.
U1-24	0057	PI Feedback Value PI Feedback	Displays the feedback signal when PI control is used.
U1-28	005B	CPU Number CPU ID	Displays control board hardware revision.
U1-29	005C	kWh kWh Lo 4 Digits	Displays the accumulated kWh.
U1-30	005D	MWh kWh Hi 5 Digits	Displays the accumulated MWh.
U1-34	0061	First Parameter Causing an OPE OPE Detected	Displays the parameter number causing an "OPE" fault.
U1-36	0063	PI Input PI Input	Displays the "error" in the PI regulator. (U1-36 = PI Set-point - PI Feedback).
U1-37	0064	PI Output PI Output	Displays the output of the PI as a percentage of maximum frequency (E1-04).
U1-38	0065	PI Set-point PI Set-point	Displays the setpoint of the PI regulator (U1-38 = PI reference + PI bias).
U1-39	0066	Memobus Communication Error Code Transmit Err	
U1-40	0067	Heatsink Cooling Fan Operation Time FAN Elapsed Time	Displays total operating time of the heatsink cooling fan.
U1-62	007D	Running Queue No Running Queue No	Position in the iQpump Memobus Multiplex Running Queue
U1-67	009B	Network Activity Network Activity	Shows network traffic. A fluctuating number from 0 to 1000 denotes activity, while a relatively constant 0 denotes no activity. Unit changes based on network status: <<->: Drive can not communicate to other drives <+>: Drive is a Node on a network <M>: Drive is a Master on an iQpump Network
U1-68	0009C	Time to Alternate Time to Alternate	Time remaining before a drive requests alternation which is dependent on P9-04.
U1-90	0720	Pump Set-point Pump Set-point	Displays drive setpoint. Resolution 0.1 Note: Does not include setpoint compensation (U1-93).
U1-91	0721	Pump Feedback Pump Feedback	Displays scaled feedback. Resolution 0.1

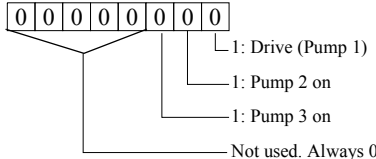
Parameter No.	Addr. Hex	Parameter Name Digital Operator Display	Description
			Monitor
U1-92	0722	Pump Status Pump Status	Display pump running status. 
U1-93	723	Total Set-point Compensation Total SP Comp.	Displays total absolute setpoint compensation. Resolution 1.
U1-94	724	Motor Speed Motor Speed	Displays motor speed (rpm). Used for no-flow detection (P2 Group).
U1-95	725	Flow Rate Flow Rate	Displays the flow rate, based upon the voltage present on Terminal A1 and parameters P6-01 and P6-02. A two second 1st order filter will be applied to this monitor.
U1-96	72A	Volume Accumulated (fine) Volume (fine)	Displays the volume that has been measured by Terminal A1. Total volume can be calculated as follows: Total Volume = U1-97 x 1000 + U1-96. Value retained in EEPROM.
U1-97	72B	Volume Accumulated (course) Volume (course)	Displays the volume that has been measured by Terminal A1. Total volume can be calculated as follows: Total Volume = U1-97 x 1000 + U1-96. Value retained in EEPROM.
U1-98	72C	Water Level Water Level	Displays the amount of water above the water level sensor.
U1-99	72D	Anti-No-Flow Timer ANF Timer	When this value reaches the P2-24 setting, the Anti-No-Flow feature begins to reduce the output frequency.

Fault Trace List

Table 3 Fault Trace List

Parameter No.	Addr. Hex	Fault Trace
U2-01	0080	Current Fault Current Fault
U2-02	0081	Previous Fault Last Fault
U2-03	0082	Frequency Reference at Most Recent Fault Frequency Ref
U2-04	0083	Output Frequency at Most Recent Fault Output Freq
U2-05	0084	Output Current at Most Recent Fault Output Current
U2-07	0086	Output Voltage at Most Recent Fault Output Voltage
U2-08	0087	DC Bus Voltage at Most Recent Fault DC Bus Voltage
U2-09	0088	Output Power at Most Recent Fault Output kWatts
U2-11	008A	Input Terminal Status at Most Recent Fault. The format is the same as for U1-10. Input Term Sts
U2-12	008B	Output Terminal Status at Most Recent Fault. The format is the same as for U1-11. Output Term Sts
U2-13	008C	Drive Operation Status at Most Recent Fault. The format is the same as for U1-12. Inverter Status
U2-14	008D	Cumulative Operation Time at Most Recent Fault Elapsed time

Note: Fault trace is not executed at CPF00, CPF01, CPF03, UVI and UV2.

Fault History List

Table 4 Fault History List

Parameter No.	Addr. Hex	Fault History
U3-01	0090	Most Recent Fault Last Fault
U3-02	0091	2nd Most Recent Fault Fault Message 2
U3-03	0092	3rd Most Recent Fault Fault Message 3
U3-04	0093	4th Most Recent Fault Fault Message 4
U3-05	0094	Cumulative Operation Time at Most Recent Fault Elapsed Time 1
U3-06	0095	Cumulative Operation Time at 2nd Most Recent Fault Elapsed Time 2
U3-07	009B	Cumulative Operation Time at 3rd Most Recent Fault Elapsed Time 3
U3-08	0097	Cumulative Operation Time at 4th Most Recent Fault Elapsed Time 4
U3-09	0804	5th Most Recent Fault Fault Message 5
U3-10	0805	6th Most Recent Fault Fault Message 6
U3-11	0806	7th Most Recent Fault Fault Message 7
U3-12	0807	8th Most Recent Fault Fault Message 8
U3-13	0808	9th Most Recent Fault Fault Message 9
U3-14	0809	10th Most Recent Fault Fault Message 10
U3-15	080E	Cumulative Operation Time at 5th Most Recent Fault Elapsed Time 5
U3-16	080F	Cumulative Operation Time at 6th Most Recent Fault Elapsed Time 6
U3-17	0810	Cumulative Operation Time at 7th Most Recent Fault Elapsed Time 7
U3-18	0811	Cumulative Operation Time at 8th Most Recent Fault Elapsed Time 8
U3-19	0812	Cumulative Operation Time at 9th Most Recent Fault Elapsed Time 9
U3-20	0813	Cumulative Operation Time at 10th Most Recent Fault Elapsed Time 10
Note: Faults such as CPF00, CPF01, CPF02, CPF03, UV1, and UV02 are not stored in fault history.		

Table 5 Decimal to Hex Conversion

Decimal	Hex	Decimal	Hex
1	1	51	33
2	2	52	34
3	3	53	35
4	4	54	36
5	5	55	37
6	6	56	38
7	7	57	39
8	8	58	3A
9	9	59	3B
10	A	60	3C
11	B	61	3D
12	C	62	3E
13	D	63	3F
14	E	64	40
15	F	65	41
16	10	66	42
17	11	67	43
18	12	68	44
19	13	69	45
20	14	70	46
21	15	71	47
22	16	72	48
23	17	73	49
24	18	74	4A
25	19	75	4B
26	1A	76	4C
27	1B	77	4D
28	1C	78	4E
29	1D	79	4F
30	1E	80	50
31	1F	81	51
32	20	82	52
33	21	83	53
34	22	84	54
35	23	85	55
36	24	86	56
37	25	87	57
38	26	88	58
39	27	89	59
40	28	90	5A
41	29	91	5B
42	2A	92	5C
43	2B	93	5D
44	2C	94	5E
45	2D	95	5F
46	2E	96	60
47	2F	97	61
48	30	98	62
49	31	99	63
50	32	100	64



Appendix: B

Capacity Related Parameters

This appendix lists the parameters affected by the Drive Capacity setting of o2-04.

B.1 Drive Capacity	204
B.2 Parameters Affected by o2-04	205
B.3 Capacity Related Parameter Values	206

B.1 Drive Capacity

Parameter o2-04 sets the iQpump drive capacity according to the model number. Parameter o2-04 requires adjustment when replacing a control board.

If a Control PCB is changed, set parameter o2-04 to the the appropriate value listed in *Table B.1* for the iQpump drive model number the first time the iQpump drive is powered up. After properly setting parameter o2-04, a 2-wire or 3-wire initialization must be performed by setting parameter A1-03 = 2220 or A1-03 = 3330 to automatically program the values of all other parameters listed in *Table B.2* to the factory settings for that particular iQpump drive rating.

Table B.1 Drive Capacity Selection

Voltage	Model Number (CIMR-P7U□-107)	o2-04 Setting	Nominal Hp
208-240 Vac	CIMR-P7U20P4	0	0.5 / 0.75
	CIMR-P7U20P7	1	1
	CIMR-P7U21P5	2	1.5 / 2
	CIMR-P7U22P2	3	3
	CIMR-P7U23P7	4	5
	CIMR-P7U25P5	5	7.5
	CIMR-P7U27P5	6	10
	CIMR-P7U2011	7	15
	CIMR-P7U2015	8	20
	CIMR-P7U2018	9	25
	CIMR-P7U2022	A	30
	CIMR-P7U2030	B	40
208-230 Vac	CIMR-P7U2037	C	50
	CIMR-P7U2045	D	60
	CIMR-P7U2055	E	75
	CIMR-P7U2075	F	75 / 100
	CIMR-P7U2090	10	125
	CIMR-P7U2110	11	150
480 Vac	CIMR-P7U40P4	20	0.5 / 0.75
	CIMR-P7U40P7	21	1
	CIMR-P7U41P5	22	1.5 / 2
	CIMR-P7U42P2	23	3
	CIMR-P7U43P7	24	5
	CIMR-P7U45P5	26	7.5
	CIMR-P7U47P5	27	10
	CIMR-P7U49P0	3C	15
	CIMR-P7U4011	28	20
	CIMR-P7U4015	29	25
	CIMR-P7U4018	2A	30
	CIMR-P7U4024	3D	40
	CIMR-P7U4030	2C	50
	CIMR-P7U4037	2D	60
	CIMR-P7U4045	2E	75
	CIMR-P7U4055	2F	100
	CIMR-P7U4075	30	125
	CIMR-P7U4090	31	150
	CIMR-P7U4110	32	200
	CIMR-P7U4160	34	250
CIMR-P7U4185	35	300 / 350	
CIMR-P7U4220	36	400 / 450	
CIMR-P7U4300	37	500+	

B.2 Parameters Affected by o2-04

The factory setting of the following parameters may change when the iQpump drive capacity is changed.

Table B.2 Parameters Affected by o2-04

Parameter Number	Parameter Name Digital Operator Display
b8-04	Energy Saving Coefficient Value Energy Save COEF
C6-02	Carrier Frequency Selection CarrierFreq Sel
E2-01	Motor Rated Current Motor Rated FLA
E2-03	Motor No Load Current No-Load Current
E2-05	Motor Line-to-Line Resistance Term Resistance
L2-02	Momentary Power Loss Ride-thru Time PwrL Ridethru t
L2-03	Momentary Power Loss Minimum Base Block Time PwrL Baseblock t
L2-04	Momentary Power Loss Voltage Recovery Ramp Time PwrL V/F Ramp t
L8-02	Overheat Pre-Alarm Level OH Pre-Alarm Lvl
L8-06	Input Phase Loss Detection Level Ph Loss In Lvl
o2-04	Drive/kVA Selection Inverter Model #

B.3 Capacity Related Parameter Values

The following tables detail the factory default settings for the parameters that are affected by the setting of parameter o2-04.

Table B.3 208/240 Vac iQpump Drives

Drive Model CIMR-P7U□-107	Nominal Hp	Factory Default for b8-04	Factory Default for E2-01	Factory Default for E2-03	Factory Default for E2-05	Factory Default for L2-02	Factory Default for L2-03	Factory Default for L2-04	Factory Default for L8-02	Factory Default for L8-06
20P4	0.5 / 0.75	288.2	1.9	1.2	9.842	0.1	0.1	0.3	95 °C	5
20P7	2	223.7	3.3	1.8	5.156	0.1	0.2	0.3	95 °C	7.5
21P5	1.5 / 2	169.4	6.2	2.8	1.997	0.2	0.3	0.3	95 °C	10
22P2	3	156.8	8.5	3.0	1.601	0.3	0.4	0.3	100 °C	12
23P7	5	122.9	14.0	4.5	0.771	0.5	0.5	0.3	95 °C	12
25P5	7.5	94.75	19.6	5.1	0.399	1.0	0.6	0.3	95 °C	10
27P5	10	72.69	26.6	8.0	0.288	1.0	0.7	0.3	95 °C	17
2011	15	70.44	39.7	11.2	0.230	1.0	0.8	0.3	95 °C	21
2015	20	63.13	53.0	15.2	0.138	2.0	0.9	0.3	95 °C	17
2018	25	57.87	65.8	15.7	0.101	2.0	1.0	0.6	100 °C	15
2022	30	51.79	77.2	18.5	0.079	2.0	1.0	0.6	90 °C	24
2030	40	46.27	105.0	21.9	0.064	2.0	1.1	0.6	90 °C	20
2037	50	38.16	131.0	38.2	0.039	2.0	1.1	0.6	95 °C	18
2045	60	35.78	160.0	44.0	0.030	2.0	1.2	0.6	100 °C	20
2055	75	31.35	190.0	45.6	0.022	2.0	1.2	0.1	105 °C	17
2075	75 / 100	23.10	260.0	72.0	0.023	2.0	1.3	0.1	110 °C	16
2090	125	20.65	260.0	72.0	0.023	2.0	1.5	0.1	100 °C	18
2110	150	18.12	260.0	72.0	0.023	2.0	1.7	0.1	95 °C	20

Note: b8-04 = Energy Savings Coefficient
 E2-01 = Motor Rated Current
 E2-03 = Motor No-Load Current
 E2-05 = Motor Line-to-Line Resistance
 L2-02 = Momentary Power Loss Ride-Thru Time
 L2-03 = Momentary Power Loss Minimum Base Block Time
 L2-04 = Momentary Power Loss Voltage Recovery Ramp Time
 L8-02 = Overheat Pre-Alarm Level
 L8-06 = Input Phase Loss Detection Level

Table B.4 480 Vac iQpump Drives

Drive Model CIMR-P7U□-107	Nominal Hp	Factory Default for b8-04	Factory Default for E2-01	Factory Default for E2-03	Factory Default for E2-05	Factory Default for L2-02	Factory Default for L2-03	Factory Default for L2-04	Factory Default for L8-02	Factory Default for L8-06
40P4	0.5 / 0.75	576.40	1.0	0.6	38.198	0.1	0.1	0.3	95 °C	5
40P7	1	447.40	1.6	0.8	22.459	0.1	0.2	0.3	95 °C	7.5
41P5	1.5 / 2	338.80	3.1	1.4	10.100	0.2	0.3	0.3	95 °C	10
42P2	3	313.60	4.2	1.5	6.495	0.3	0.4	0.3	90 °C	10
43P7	5	245.80	7.0	2.3	3.333	0.5	0.5	0.3	95 °C	12
45P5	7.5	189.50	13.3	2.6	1.595	1.0	0.6	0.3	95 °C	10
47P5	10	145.38	19.9	4.0	1.152	1.0	0.7	0.3	90 °C	20
49P0	15	145.46	21.0	5.6	0.922	2.0	0.8	0.3	95 °C	23
4011	20	140.88	26.5	5.6	0.922	2.0	0.8	0.3	95 °C	23
4015	25	126.26	32.9	7.6	0.550	2.0	0.9	0.3	95 °C	17
4018	30	115.74	52.3	7.8	0.403	2.0	1.0	0.6	98 °C	17
4024	40	89.08	52.0	8.6	0.269	2.0	1.1	0.6	85 °C	20
4030	50	92.54	65.6	10.9	0.269	2.0	1.1	0.6	85 °C	20
4037	60	76.32	79.7	19.1	0.155	2.0	1.1	0.6	85 °C	20
4045	75	71.56	95.0	22.0	0.122	2.0	1.2	0.6	90 °C	20
4055	100	67.20	130.0	24.0	0.088	2.0	1.2	1.0	90 °C	20
4075	125	46.20	130.0	36.0	0.092	2.0	1.3	1.0	98 °C	16
4090	150	38.91	156.0	40.0	0.056	2.0	1.5	1.0	108 °C	16
4110	200	36.23	190.0	49.0	0.046	2.0	1.7	1.0	100 °C	16
4160	250	30.13	270.0	70.0	0.029	2.0	1.8	1.0	108 °C	14
4185	300 / 350	30.57	310.0	81.0	0.025	2.0	0.7	1.0	95 °C	15
4220	400 / 450	27.13	370.0	96.0	0.020	2.0	0.8	1.0	100 °C	15
4300	500+	21.76	500.0	130.0	0.014	2.1	0.9	1.0	95 °C	15

Note: b8-04 = Energy Savings Coefficient
 E2-01 = Motor Rated Current
 E2-03 = Motor No-Load Current
 E2-05 = Motor Line-to-Line Resistance
 L2-02 = Momentary Power Loss Ride-Thru Time
 L2-03 = Momentary Power Loss Minimum Base Block Time
 L2-04 = Momentary Power Loss Voltage Recovery Ramp Time
 L8-02 = Overheat Pre-Alarm Level
 L8-06 = Input Phase Loss Detection Level

B.3 Capacity Related Parameter Values

Carrier Frequency Parameter Factory Defaults:

208V – 240V Drives		
Model CIMR-P7	C6-02 Carrier Frequency (kHz)	C6-03 Carrier Frequency (kHz)
20P4	3	8.0 kHz*
20P7	3	8.0 kHz*
21P5	3	8.0 kHz*
22P2	3	8.0 kHz*
23P7	3	8.0 kHz*
25P5	3	8.0 kHz*
27P5	3	8.0 kHz*
2011	3	8.0 kHz*
2015	3	8.0 kHz*
2018	3	8.0 kHz*
2022	3	8.0 kHz*
2030	3	8.0 kHz*
2037	2	5.1 kHz
2045	2	5.1 kHz
2055	3	8.0 kHz*
2075	1	2.0 kHz
2090	1	2.0 kHz
2110	1	2.0 kHz

480V Drives		
Model CIMR-P7	C6-02 Carrier Frequency (kHz)	C6-03 Carrier Frequency (kHz)
40P4	3	8.0 kHz*
40P7	3	8.0 kHz*
41P5	3	8.0 kHz*
42P2	3	8.0 kHz*
43P7	3	8.0 kHz*
44P0	3	8.0 kHz*
45P5	3	8.0 kHz*
47P5	3	8.0 kHz*
49P0	3	8.0 kHz*
4011	3	8.0 kHz*
4015	3	8.0 kHz*
4018	3	8.0 kHz*
4022	3	8.0 kHz*
4024	3	8.0 kHz*
4030	3	8.0 kHz*
4037	3	8.0 kHz*
4045	3	8.0 kHz*
4055	2	5.1 kHz
4075	2	5.1 kHz
4090	3	8.0 kHz*
4110	2	5.1 kHz
4132	2	5.1 kHz
4160	2	5.1 kHz
4185	1	2.0 kHz
4220	1	2.0 kHz
4300	1	2.0 kHz

* = when an option card is installed, C6-03 max is 7.0 kHz.



Appendix: C

Specifications

This appendix details the standard iQpump drive specifications.

C.1 Standard iQpump Drive Specifications.....	210
--	------------

C.1 Standard iQpump Drive Specifications

The standard iQpump drive specifications are listed in the following tables.

◆ 208-240 Vac

Table C.1 208-240 Vac iQpump Drive Specifications

Model Number CIMR-P7U□-107		20P4	20P7	21P5	22P2	23P7	25P5	27P5	2011	2015	2018	2022	2030	
Output Ratings	Rated output capacity (kVA)	1.4	1.8	3.0	4.1	6.4	8.8	12.0	18.0	23.0	29.0	34.0	44.0	
	Motor HP	208 V	0.5 / 0.75	1	1.5/2	3	5	7.5	10	15	20	25	30	40
		230 V	0.5 / 0.75	1	1.5/2	3	5	7.5	10	15	20	25	30	40
	Rated output current (A)	3.6	4.6	7.8	10.8	16.8	23.0	31.0	46.2	59.4	74.8	88.0	115.0	
	Max. output voltage (V)	3-phase; 200, 208, 220, 230, or 240 Vac (Proportional to input voltage)												
Max. output frequency (Hz)	120 Hz													
Power Supply Characteristics	Rated voltage (V) Rated frequency (Hz)	3-phase, 200/208/220/230/240 Vac, 50/60 Hz												
	Rated input current (A)	4.3	5.5	9.4	13	20	24	37	53	70	89	98	120	
	Allowable voltage fluctuation	+ 10 %, - 15 %												
	Allowable frequency fluctuation	±5 %												
Control Characteristics	Measures for power supply harmonics	DC Reactor	Optional									Built-in		
		12-Pulse Rectification	Not possible									Possible		
Note: The maximum applicable motor output is given for a standard 4-pole motor. When selecting the actual motor and drive, be sure that the drive's rated output current is applicable for the motor's rated current. A phase-shifting transformer is required on the power supply for 12-pulse rectification.														

Table C.1 208-230 Vac iQpump Drive Specifications (Continued)

Model Number CIMR-P7U□-107		2037	2045	2055	2075	2090	2110	
Output Ratings	Rated output capacity (kVA)	62.0	73.0	82	120.0	140.0	160.0	
	Motor HP	208V	50	60	75	100	125	150
		230V	50 / 60	75	—	100 / 125	—	150
	Rated output current (A)	162.0	192.0	215	312.0	360.0	415.0	
	Max. output voltage (V)	3-phase; 200, 208, 220, 230, or 240 Vac (Proportional to input voltage)						
Max. output frequency (Hz)	120 Hz							
Power Supply Characteristics	Rated voltage (V) Rated frequency (Hz)	3-phase, 200/208/220/230/240 Vac, 50/60 Hz						
	Rated input current (A)	180	212	237	350	396	457	
	Allowable voltage fluctuation	+ 10 %, - 15 %						
	Allowable frequency fluctuation	±5 %						
Control Characteristics	Measures for power supply harmonics	DC Reactor	Built-in					
		12-Pulse Rectification	Possible					
Note: The maximum applicable motor output is given for a standard 4-pole motor. When selecting the actual motor and drive, be sure that the drive's rated output current is applicable for the motor's rated current. A phase-shifting transformer is required on the power supply for 12-pulse rectification.								

◆ 480 Vac

Table C.2 480 Vac iQpump Drive Specifications

Model Number CIMR-P7U□-107		40P4	40P7	41P5	42P2	43P7	45P5	47P5	49P0	4011	4015	4018
Output Ratings	Rated output capacity (kVA)	1.4	1.6	2.8	4.0	5.8	9.5	13.0	16.0	21.0	26.0	30.0
	Motor HP (460V)	0.5 / 0.75	1	1.5/2	3	5	7.5	10	15	20	25	30
	Rated output current (A)	1.8	2.1	3.7	5.3	7.6	12.5	17.0	21.0	27.0	34.0	40.0
	Max. output voltage (V)	3-phase; 380, 400, 415, 440, 460, or 480 Vac (Proportional to input voltage.)										
	Max. output frequency (Hz)	120 Hz										
Power Supply Characteristics	Rated voltage (V) Rated frequency (Hz)	3-phase, 380, 400, 415, 440, 460 or 480 Vac, 50/60 Hz										
	Rated input current (A)	2.2	2.5	4.4	6.4	9.0	15	20	26	33	40	48
	Allowable voltage fluctuation	+ 10 %, - 15 %										
	Allowable frequency fluctuation	±5 %										
Control Characteristics	Measures for power supply harmonics	DC Reactor	Optional									
		12-pulse Rectification	Not Possible									

Table C.2 480 Vac iQpump Drive Specifications (Continued)

Model Number CIMR-P7U□-107		4024	4030	4037	4045	4055	4075	4090	4110	4160	4185	4220	4300
Output Ratings	Rated output capacity (kVA)	40.0	51.0	59.0	73.0	95.0	120.0	140.0	180.0	230.0	315.0	390.0	510.0
	Motor HP (460V)	40	50	60	75	100	125	150	200	250	300 / 350	400 / 450	500+
	Rated output current (A)	52.0	67.2	77.0	96.0	125.0	156.0	180.0	240.0	304.0	414.0	515.0	675.0
	Max. output voltage (V)	3-phase, 380, 400, 415, 440, 460 or 480 Vac (Proportional to input voltage)											
	Max. output frequency (Hz)	120 Hz											
Power Supply Characteristics	Max. voltage (V) Rated frequency (Hz)	3-phase, 380, 400, 415, 440, 460, or 480 Vac, 50/60 Hz											
	Rated input current (A)	57	74	85	106	134	172	198	264	334	456	567	743
	Allowable voltage fluctuation	+ 10 %, - 15 %											
	Allowable frequency fluctuation	±5 %											
Control Characteristics	Measures for power supply harmonics	DC Reactor	Built-in										
		12-Pulse Rectification	Possible										

Note: The maximum applicable motor output is given for a standard 4-pole motor. When selecting the actual motor and drive, be sure that the drive's rated output current is applicable for the motor's rated current.
A 3-wire phase-shifting transformer is required on the power supply for 12-pulse rectification.

C.1 Standard iQpump Drive Specifications

Table C.3 Common iQpump (P7U) Drive Specifications

Model Number CIMR-P7U□-107		Specification
Control Characteristics	Control method	Sine wave PWM V/f control
	Speed range	40:1
	Speed control accuracy	±2 to 3 % (77 °F ± 50 °F) (25 °C ± 10 °C)
	Frequency accuracy (temperature characteristics)	Digital references: ± 0.01 % (14 °F to 104 °F) (-10 °C to +40 °C)
		Analog references: ±0.1 % (77 °F ± 50 °F) (25 °C ±10 °C)
	Frequency setting resolution	Digital references: 0.01 Hz
		Analog references: 0.025 / 50 Hz (10 bit with sign)
	Frequency setting signal (Speed Command)	0-10 Vdc, 4 ~ 20 mA
Acceleration/Deceleration time	0.0 to 6000.0 s (2 selectable combinations of independent acceleration and deceleration settings)	
Main control functions	Restarting for momentary power loss, bi-directional speed search, overtorque detection, 5 preset speeds, acceleration/deceleration time changes, S-curve acceleration, 3-wire sequence, auto-tuning, cooling fan ON/OFF control, torque compensation, jump frequencies, upper and lower limits for frequency references, DC braking for starting and stopping, high-slip braking, PI control (with sleep function), energy-saving control, Modbus communications (RS-485 / 422, 19.2 kbps maximum), fault reset, and copy function	
Protective Functions	Motor protection	Protection by electronic thermal overload relay
	Fuse blown protection	Stops for fuse blown
	Overload capacity and maximum current	110 % of rated output current for 60 seconds
	Overvoltage protection	208-240 Vac: Stops when main-circuit DC voltage is above 410V
		480 Vac: Stops when main-circuit DC voltage is above 820V
	Undervoltage protection	208-240 Vac: Stops when main-circuit DC voltage is below 190V
		480 Vac: Stops when main-circuit DC voltage is below 380V
	Momentary power loss ridethru	Power Interruptions of 15 ms or more By selecting the momentary power loss method, operation can be continued if power is restored within 2sec
	Cooling fin overheating	Protection by thermistor
	Stall prevention	Stall prevention during acceleration, deceleration, or running
Grounding protection	Protection by electronic circuits. (50 % of inverter rated current)	
Charge indicator	Lit when the main circuit DC voltage is approx. 50 Vdc or more	
Enclosure Type	Enclosed wall-mounted type (NEMA 1): CIMR-P7U20P4 thru 2030 and 40P4 thru 4055 Open chassis type (IP00): CIMR-P7U2022 thru 2110 and 4030 thru 4300	
Environment	Ambient operating temperature	14 °F to 104 °F (-10 °C to 40 °C) NEMA 1 type 14 °F to 113 °F (-10 °C to 45 °C) Open chassis type
	Ambient operating humidity	95 % max. (with no condensation)
	Storage temperature	-4 °F to 140 °F (- 20 °C to + 60 °C) short-term temperature during transportation
	Application site	Indoor (no corrosive gas, dust, etc.)
	Altitude	3300 ft. (1000 m), higher altitudes by derate
	Vibration	10 to 20 Hz, 32 ft / s ² (9.8 m s ²) max: 20 to 50 Hz, 6.5 ft / s ² (2 m / s ²) max
	Approval Agencies	UL File E143427



Appendix: D

Communication

This appendix details the specifications, connections, and programming of the iQpump drive for Modbus communications. This iQpump drive also contains embedded APOGEE™ FLN and Metasys® communication protocols. For details regarding APOGEE™ FLN, please refer to the P7 APOGEE™ FLN Technical Manual (TM.iQp.21). For details regarding Metasys®, please refer to the Technical Manual (TM.iQp.22). These two documents can be found on the CD-ROM included with this iQpump drive or at <http://iQpump.yaskawa.com>.

D.1 Using Modbus Communication	214
D.2 Modbus Function Code Details	218
D.3 Modbus Data Tables	220
D.4 Modbus Self-Diagnosis	225

D.1 Using Modbus Communication

Serial communication can be performed with Direct Digital Controllers (DDCs) or similar devices using the Modbus protocol.

◆ Modbus Communication Configuration

Modbus communication is configured using 1 master (PLC) and a maximum of 31 slaves. Serial communication between master and slave is normally initiated by the master and responded to by the slaves.

The master performs serial communication with one slave at a time. Consequently, the slave address of each slave must be initially set, so that the master can perform serial communication using that address. Slaves receiving commands from the master perform the specified functions, and send a response back to the master.

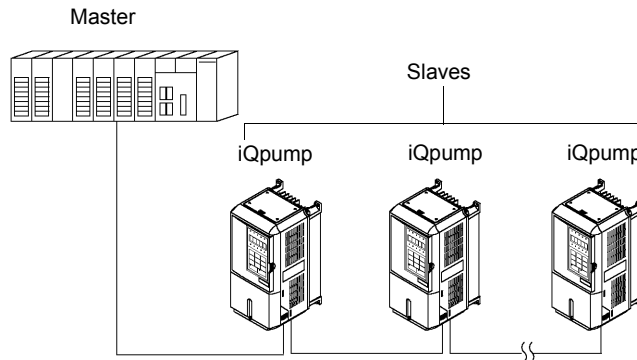

Figure D.1 Example of Connections between Master and Drive

◆ Communication Specifications

The Modbus communication specifications are shown below:

Table D.1 Modbus Communication Specifications

Item	Specifications	
Interface	RS-422, RS-485	
Communications Cycle	Asynchronous (Start-stop synchronization)	
Communications Parameters	Baud rate:	Select from 1200, 2400, 4800, 9600, and 19200 bps.
	Data length:	8 bits fixed
	Parity:	Select from even, odd, or none.
	Stop bits:	1 bit selected
Communications Protocol	Modbus	
Number of Connectable Units	31 units max.	

◆ Communication Connection Terminal

Modbus communication uses the following terminals: S+, S-, R+, and R-. The terminating resistance must be turned ON only if the iQpump drive is at the very end of the Serial Communication chain. Set the terminating resistance by turning ON pin 1 of switch S1.

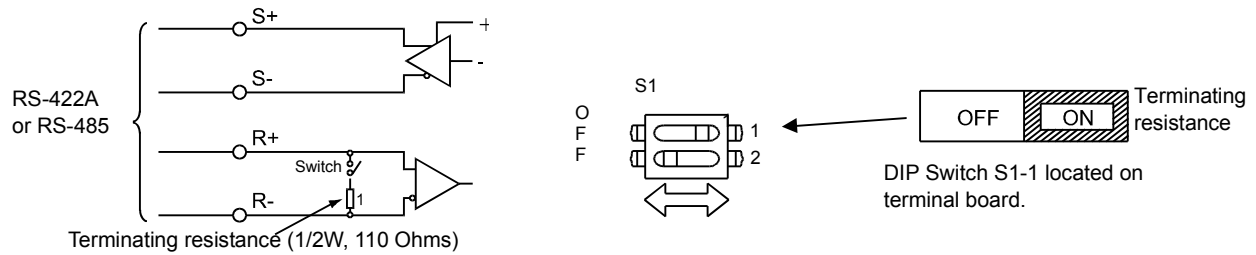

Figure D.2 Communication Connection Terminals and Terminating Resistance

IMPORTANT:

1. Separate the communication cables from the main circuit cables and control circuit wiring.
2. Use shielded cables for the communication cable, and use proper shield clamps.
3. When using RS-485 communication, connect S+ to R+, and S- to R-, on the control circuit terminal board. See **Figure D.3** below.
4. Shield at one end only.

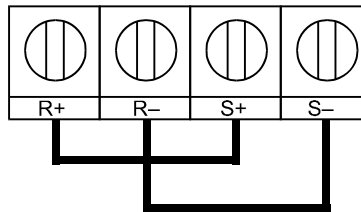

Figure D.3 RS-485 Communication Connection

◆ Procedure for Setting Up Communication

Use the following procedure to perform communication with the DDC.

1. Turn OFF the input to the iQpump drive power and connect the communication cable between the PLC and the iQpump drive.
2. Turn ON the input power to the iQpump drive.
3. Set the required communication parameters (H5-01 to H5-09) using the digital operator.
4. Turn OFF the input to the iQpump drive power, and check that the digital operator display has disappeared.
5. Turn ON the input power to the iQpump drive once again.
6. Perform communication with the DDC.

D.1 Using Modbus Communication

■ Related Parameters

Table D.2 Serial Communication Related Parameters

Parameter No.	Modbus Address	Parameter Name Digital Operator Display	Description	Setting Range	Factory Setting	Menu Location
b1-01	0180H	Frequency Reference Selection Reference Source	Selects the speed command (frequency reference) input source. 0: Operator - Digital preset speed d1-01 1: Terminals - Analog Input Terminal A1 (or Terminal A2 see parameter H3-13) 2: Serial Com - RS-485 terminals R+, R-, S+ and S- 3: Option PCB - Option board connected at 2CN	0 ~ 3	0	Programming
b1-02	0181H	Run Command Selection Run Source	Selects the run command input source. 0: Operator - "Hand" and "Off" keys on digital operator 1: Terminals - Contact Closure on Terminal S1 2: Serial Com - RS-485 terminals R+, R-, S+ and S- 3: Option PCB - Option board connected at 2CN 5: Timed Run <0034>	0 to 3, 5	0	Programming
H5-01	0425	Drive Node Address Serial Com Adr	Selects drive station node number (address) for Terminals R+, R-, S+, S-. Note: An address of "0" disables serial com. Drive power must be cycled before the changes will take effect. *Range is dependent on P9-25, if P1-01 = 3. <0034>	0 ~ 20*	1F	Programming
H5-02	0426	Communication Speed Selection Serial Baud Rate	Selects the baud rate for Terminals R+, R-, S+ and S-. 0: 1200 Baud 1: 2400 Baud 2: 4800 Baud (APOGEE FLN) 3: 9600 Baud (Metasys N2) 4: 19200 Baud Note: Drive power must be cycled before the changes will take effect. <0034>	0 ~ 4	3	Programming
H5-03	0427	Communication Parity Selection Serial Com Sel	Selects the communication parity for Terminals R+, R-, S+ and S-. 0: No Parity 1: Even Parity 2: Odd Parity Note: Drive power must be cycled before the changes will take effect. <0034>	0 ~ 2	0	Programming
H5-04	0428	Stopping Method after Communication Error Serial Fault Sel	Selects the stopping method when a communication error is detected. 0: Ramp to Stop 1: Coast to Stop 2: Fast-Stop 3: Alarm Only	0 ~ 3	3	Programming
H5-05	0429	Communication Error Detection Selection Serial Flt Dtct	Enables or disables the communications timeout detection function. 0: Disabled - A communications loss will NOT cause a communications fault. 1: Enabled - If communications are lost for more than the time specified in parameter H5-09, a communications fault will occur.	0 ~ 1	1	Programming
H5-06	042A	Drive Transmit Wait Time Transmit WaitTIM	Sets the time from when the drive receives data to when the drive sends data.	5 ~ 65	5 ms	Programming
H5-07	042B	RTS Control Selection RTS Control Sel	Enables or disables "request to send" (RTS) control: 0: Disabled (RTS is always on) 1: Enabled (RTS turns on only when sending)	0 ~ 1	1	Programming
H5-08	042C	Communication Protocol Selection Com Protocol Sel	0: MEMOBUS / Modbus 1: N2 (Metasys) 2: FLN (APOGEE)	0 ~ 2	0	Programming
H5-09	0435	Communication Error Detection Time CE Detect Time	Determines how long communications must be lost before a fault is annunciated. Works in conjunction with parameters H5-05 and H5-04.	0.0 ~ 10.0	2.0 s	Programming
<p>◆ Denotes that parameter can be changed when the iQpump drive is running. * After these parameters are changed, iQpump drive power must be cycled before the changes will take effect. # Hex</p>						

Modbus communication can perform the following operations regardless of the settings in b1-01 and b1-02:

1. Monitoring operation status of the iQpump drive.
2. Setting and reading iQpump drive parameters.
3. Resetting faults.
4. Input multi-function commands.

IMPORTANT: An OR operation is performed between the multi-function command input from the DDC and the command input from multi-function digital input terminals S3 to S7.

■ **Message Format**

In Modbus communication, the master sends commands to the slave, and the slave responds. The message format is configured for both sending and receiving as shown below. The length of the data packets is changed by the command (function) contents.

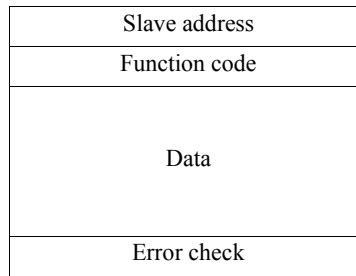

Figure D.4 Message Format

The space between messages must support the following:

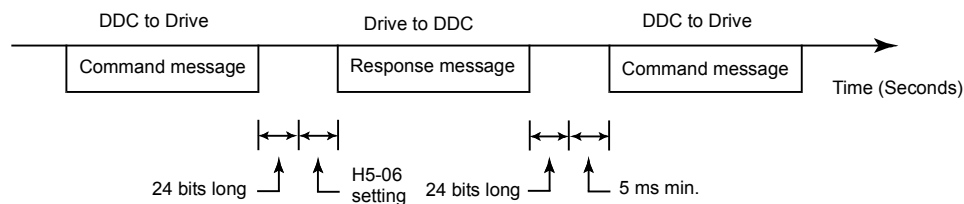

Figure D.5 Message Spacing

Slave Address

Set the iQpump drive address from 0 to 32. If 0 is selected, commands from the master will be broadcast (i.e., the iQpump drive will not return responses).

Function Code

The function code specifies commands. There are four function codes, as shown below.

Table D.3 Function Codes

Function Code (Hexadecimal)	Function	Command Message		Response Message	
		Min. (Bytes)	Max. (Bytes)	Min.* (Bytes)	Max. (Bytes)
03H	Reading / Holding Register Contents	8	8	7	37
06H	Write In Single Holding Register	8	8	8	8
08H	Loopback Test	8	8	8	8
10H	Write In Several Holding Registers	11	41	8	8

* Minimum bytes for a normal Response Message (error response message is always 5 bytes).

Data

Configure consecutive data by combining the storage register address (test code for a loopback address) and the data the register contains. The data length changes depending on the command details.

Error Check

Errors are detected during communication using CRC-16. Perform calculations using the following method:

1. The factory setting for CRC-16 communication is typically zero, but when using the Modbus system, set the factory setting to one (e.g., set all 16 bits to 1).
2. Calculate CRC-16 using MSB as slave address LSB, and LSB as the MSB of the final data.
3. Calculate CRC-16 for response messages from the slaves and compare them to the CRC-16 in the response messages.

D.2 Modbus Function Code Details

◆ Reading / Holding Register Contents (03H)

Read the contents of the storage register only for specified quantities. The addresses must be consecutive, starting from a specified address. The data content of the storage register are separated into higher 8 bits and lower 8 bits.

The following table shows message examples when reading status signals, error details, data link status, and frequency references from the slave 2 drive.

Command Message			Response Message (During Normal Operation)			Response Message (During Error)		
Slave Address		02 H	Slave Address		02 H	Slave Address		02 H
Function Code		03 H	Function Code		03 H	Function Code		83 H
Start Address	Higher	00 H	Data quantity		08 H	Error code		03 H
	Lower	20 H	1st storage register	Higher	00 H	CRC-16	Higher	F1 H
Quantity	Higher	00 H		Lower	65 H		Lower	31 H
	Lower	04 H	Next storage register	Higher	00 H			
Higher		45 H		Lower	00 H			
CRC-16	Higher	F0 H	Next storage register	Higher	00 H			
	Lower	F0 H		Lower	00 H			
			Next storage register	Higher	01 H			
				Lower	F4 H			
			CRC-16	Higher	AF H			
				Lower	82 H			

Figure D.6 Function Code 03 H Message Example

◆ Write In Single Holding Register (06H)

Command Message			Response Message (During Normal Operation)			Response Message (During Error)		
Slave address		01 H	Slave address		01 H	Slave address		01 H
Function code		06 H	Function code		06 H	80H + Function Code		86 H
Register Address	Upper	00 H	Register Address	Upper	00 H	Error code		21 H
	Lower	01 H		Lower	01 H	CRC-16	Upper	82 H
Setting Data	Upper	00 H	Setting Data	Upper	00 H		Lower	78 H
	Lower	03 H		Lower	03 H			
CRC-16	Upper	98 H	CRC-16	Upper	98 H			
	Lower	0B H		Lower	0B H			

Figure D.7 Function Code 06 H Message Example

◆ Loopback Test (08H)

The loopback test returns the command message directly as the response message without changing the contents to check the communications between the master and slave. Set user-defined test code and data values.

The following table shows a message example when performing a loopback test with the slave 1 drive.

Table D.4 Function Code 08H Message Example

Command Message			Response Message (During Normal Operation)			Response Message (During Error)		
Slave address		01 H	Slave address		01 H	Slave address		01 H
Function code		08 H	Function code		08 H	Function code		89 H
Test Code	Higher	00 H	Test Code	Higher	00 H	Error Code		01 H
	Lower	00 H		Data	Lower	00 H	CRC-16	Higher
Data	Higher	A5 H	Data		Higher	A5 H		CRC-16
	Lower	37 H		CRC-16	Lower	37 H	Higher	
CRC-16	Higher	DA H	CRC-16		Higher	DA H	Lower	8D H
	Lower	8D H		CRC-16	Lower	8D H		

◆ Write In Several Holding Registers (10H)

Write the specified data to the registers from the specified addresses. The written data must be consecutive, starting from the specified address in the command message: Higher 8 bits, then lower 8 bits, in storage register address order.

The following table shows an example of a message when a forward run command has been set at a speed command of 60.0 Hz in the slave 1 drive by the PLC.

Table D.5 Function Code 10H Message Example

Command Message			Response Message (During Normal Operation)			Response Message (During Error)		
Slave Address		01 H	Slave Address		01 H	Slave Address		01 H
Function Code		10 H	Function Code		10 H	Function Code		90 H
Start Address	Higher	00 H	Start Address	Higher	00 H	Error code		02 H
	Lower	01 H		Quantity	Lower	01 H	CRC-16	Higher
Quantity	Higher	00 H	Quantity		Higher	00 H		CRC-16
	Lower	02 H		CRC-16	Lower	02 H	Higher	
No. of data		04 H	CRC-16		Higher	10 H	Lower	08 H
Lead data	Higher	00 H			Lower	08 H		
	Lower	01 H						
Next data	Higher	02 H						
	Lower	58 H						
CRC-16	Higher	63 H						
	Lower	39 H						

* No. of data = 2 x (quantity)

IMPORTANT: Set the number of data specified using command messages as quantity of specified messages x 2. Handle response messages in the same way.

D.3 Modbus Data Tables

The data tables are shown below. The types of data are as follows: Reference data, monitor data and broadcast data.

◆ Reference Data

The reference data table is shown below. Reference data can be read and written to.

Table D.6 Reference Data

Register No. (Hex)	Contents		
0000	Reserved		
0001	Frequency reference		
	Bit 0	Run Forward 1: Run Forward	
	Bit 1	Run Reverse 1: Run Reverse	
	Bit 2	External fault 1: Fault (EFO)	
	Bit 3	Fault reset 1: Reset command	
	Bit 4	ComNet	
	Bit 5	ComCtrl	
	Bit 6	Multi-function digital input command 3	
	Bit 7	Multi-function digital input command 4	
	Bit 8	Multi-function digital input command 5	
	Bit 9	Multi-function digital input command 6	
	Bit A	Multi-function digital input command 7	
Bits B to F	Not used		
0002	Frequency reference (Set units using parameter o1-03)		
0003 to 0005	Not used		
0006	PI Setpoint		
0007	Analog output 1 setting (-11 V = 726 to 11 V = 726) → 10 V = 660		
0008	Analog output 2 setting (-11 V = 726 to 11 V = 726) → 10 V = 660		
0009	Multi-function contact output setting		
	Bit 0	Digital output 1 (Terminal M1-M2) 1: ON 0: OFF	
	Bit 1	Digital output 2 (Terminal M3-M4) 1: ON 0: OFF	
	Bit 2	Not Used	
	Bits 3 to 5	Not used	
	Bit 6	Set fault contact (terminal MA-MC) output using bit 7. 1: ON 0: OFF	
	Bit 7	Fault contact (terminal MA-MC) 1: ON 0: OFF	
	Bits 8 to F	Not used	
000A to 000E	Not used		
000F	Reference selection settings		
	Bit 0	Not used	
	Bit 1	Input PI setpoint 1: Enabled 0: Disabled	
	Bits 3 to B	Not used	
	C	Broadcast data terminal S5 input 1: Enabled 0: Disabled	
	D	Broadcast data terminal S6 input 1: Enabled 0: Disabled	
	E	Broadcast data terminal S7 input 1: Enabled 0: Disabled	
	F	Not used	

Write 0 to all unused bits. Also, do not write data to reserved registers.

Monitor Data

The following table shows the monitor data. Monitor data can only be read.

Table D.7 Monitor Data

Register No. (Hex)	Contents	
0020	Drive status	
	Bit 0	Operation 1: Operating 0: Stopped
	Bit 1	Reverse operation 1: Reverse operation 0: Forward operation
	Bit 2	Drive startup complete 1: Completed 0: Not completed
	Bit 3	Fault 1: Fault
	Bit 4	Data setting error 1: Error
	Bit 5	Multi-function digital output 1 (terminal M1 - M2) 1: ON 0: OFF
	Bit 6	Multi-function digital output 2 (terminal M3 - M4) 1: ON 0: OFF
	Bit 7	Not used
	Bits 8 to F	Not used
0021	Fault details	
	Bit 0	Overcurrent (OC) Ground fault (GF)
	Bit 1	Main circuit overvoltage (OV)
	Bit 2	Drive overload (OL2)
	Bit 3	Drive overheat (OH1, OH2)
	Bit 4	Not used
	Bit 5	Fuse blown (PUF)
	Bit 6	PI feedback reference lost (FbL)
	Bit 7	External error (EF, EFO)
	Bit 8	Hardware error (CPF)
	Bit 9	Motor overload (OL1) or overtorque 1 (OL3) detected
	Bit A	PG broken wire detected (PGO), Overspeed (OS), Speed deviation (DEV)
	Bit B	Main circuit undervoltage (UV) detected
	Bit C	Main circuit undervoltage (UV1), control power supply error (UV2), inrush prevention circuit error (UV3), power loss
Bit D	Missing output phase (LF)	
Bit E	Modbus communications error (CE)	
Bit F	Operator disconnected (OPR)	
0022	Data link status	
	Bit 0	Writing data
	Bit 1	Not used
	Bit 2	Not used
	Bit 3	Upper and lower limit errors
	Bit 4	Data integrity error
	Bits 5 to F	Not used
0023	Frequency reference	U1-01
0024	Output frequency	U1-02
0025	Output voltage reference	U1-06
0026	Output current	U1-03
0027	Output power	U1-08
0028	Torque reference	U1-09
0029	Not used	
002A	Not used	

D.3 Modbus Data Tables

Register No. (Hex)	Contents	
002B	Sequence input status	
	Bit 0	Input terminal S1 1: ON 0: OFF
	Bit 1	Input terminal S2 1: ON 0: OFF
	Bit 2	Multi-function digital input terminal S3 1: ON 0: OFF
	Bit 3	Multi-function digital input terminal S4 1: ON 0: OFF
	Bit 4	Multi-function digital input terminal S5 1: ON 0: OFF
	Bit 5	Multi-function digital input terminal S6 1: ON 0: OFF
	Bit 6	Multi-function digital input terminal S7 1: ON 0: OFF
	Bits 7 to F	Not used
002C	Drive status	
	Bit 0	Operation 1: Operating
	Bit 1	Zero speed 1: Zero speed
	Bit 2	Frequency agree 1: Matched
	Bit 3	Desired frequency agree 1: Matched
	Bit 4	Frequency detection 1 1: Output frequency \leq L4-01
	Bit 5	Frequency detection 2 1: Output frequency \geq L4-01
	Bit 6	Drive startup completed 1: Startup completed
	Bit 7	Low voltage detection 1: Detected
	Bit 8	Baseblock 1: Drive output baseblock
	Bit 9	Frequency reference mode 1: Not communication 0: Communication
	Bit A	Run command mode 1: Not communication 0: Communication
	Bit B	Overtorque detection 1: Detected
	Bit C	Frequency reference lost 1: Lost
	Bit D	Retrying error 1: Retrying
	Bit E	Error (including Modbus communications time-out) 1: Error occurred
Bit F	Modbus communications time-out 1: Timed out	
002D	Multi-function digital output status	
	Bit 0	Multi-function digital output 1 (terminal M1-M2) 1: ON 0: OFF
	Bit 1	Multi-function digital output 2 (terminal M3-M4); 1: ON 0: OFF
	Bit 2	Not used
	Bits 3 to F	Not used
002E - 0030	Not used	
0031	Main circuit DC voltage	
0032 - 0037	Not used	
0038	PI feedback level (Input equivalent to 100 % / Max. output frequency; 10/1%; without sign)	
0039	PI input level ($\pm 100\%/\pm$ Max. output frequency; 10/1 %; with sign)	
003A	PI output level ($\pm 100\%/\pm$ Max. output frequency; 10/1 %; with sign)	
003B	CPU software number	
003C	Flash software number	
003D	Communication error details	
	Bit 0	CRC error
	Bit 1	Invalid data length
	Bit 2	Not used
	Bit 3	Parity error
	Bit 4	Overrun error
	Bit 5	Framing error
	Bit 6	Time-out
	Bits 7 to F	Not used
003E	KVA setting	
003F	Control method	
Note: Communication error details are stored until an error reset is input (errors can be reset while the drive is operating).		

Broadcast Data

The following table shows the broadcast data. Broadcast data can be written to.

Table D.8 Broadcast Data

Register Address (Hex)	Contents	
0001	Operation signal	
	Bit 0	Run command 1: Operating 0: Stopped
	Bit 1	Reverse operation command 1: Reverse 0: Forward
	Bits 2 and 3	Not used
	Bit 4	External error 1: Fault (set using H1-01)
	Bit 5	Error Fault 1: Reset command (set using H1-02)
	Bits 6 to B	Not used
	Bit C	Multi-function digital input terminal S5 input
	Bit D	Multi-function digital input terminal S6 input
	Bit E	Multi-function digital input terminal S7 input
0002	Bit F	Not used.
	Frequency reference	30000 / 100%

Note: Bit signals not defined in the broadcast operation signals use local node data signals continuously.

Enter Command

When writing parameters to the drive from the PLC using Modbus communication, the parameters are temporarily stored in the constant data area in the drive. To enable these parameters in the parameter data area, use the Enter command.

There are two types of Enter commands:

1. Enter commands that enable parameter data in RAM
2. Enter commands that write data to EEPROM (non-volatile memory) in the drive at the same time as enabling data in RAM.

The following table shows the Enter command data. Enter command data can only be written.

The Enter command is enabled by writing 0 to register number 0900 H or 0901 H.

Table D.9 Enter Command

Register No. (Hex)	Contents
0900	Write parameter data to EEPROM
0910	Parameter data is not written to EEPROM, but refreshed in RAM only.

IMPORTANT: The maximum number of times you can write to EEPROM using the drive is 100,000. Do not frequently execute Enter commands (0900) written to EEPROM. The Enter command registers are write-only. Consequently, if reading these registers, the register address will become invalid (Error code: 02 H).

D.3 Modbus Data Tables

Error Codes

The following table shows Modbus communication error codes.

Table D.10 Error Codes

Error Code	Contents
01H	Function code error A function code other than 03 H, 08 H, or 10 H has been set by the PLC.
02H	Invalid register number error <ul style="list-style-type: none">• The register address you are attempting to access is not recorded anywhere.• With broadcast sending, a start address other than 0000 H, 0001 H, or 0002 H has been set.
03H	Invalid quantity error <ul style="list-style-type: none">• The number of data packets being read or written is outside the range of 1 to 16.• In write mode, the number of data packets in the message is not No. of packets x 2.
21H	Data setting error <ul style="list-style-type: none">• Upper limit or lower limit error has occurred in the control data or when writing parameters.• When writing parameters, the parameter setting is invalid.
22H	Write mode error <ul style="list-style-type: none">• Attempting to write parameters to the drive during run.• Attempting to write via Enter commands during run.• Attempting to write parameters other than A1-00 to A1-05, E1-03, or 02-04 when a CPF03 (defective EEPROM) fault has occurred.• Attempting to write read-only data.
23H	Writing during main circuit undervoltage (UV) fault <ul style="list-style-type: none">• Writing parameters to the drive during UV (main circuit undervoltage) alarm.• Writing via Enter commands during UV (main circuit undervoltage) alarm.
24H	Writing error during parameters processing Attempting to write parameters while processing parameters in the drive.

Slave Not Responding

In the following cases, the slave will ignore the write function.

- When a communication error (overrun, framing, parity, or CRC-16) is detected in the command message.
- When the slave address in the command message and the slave address in the drive do not agree.
- When the data that configures the message and the data time length exceed 24 bits.
- When the command message data length is invalid.

IMPORTANT: If the slave address specified in the command message is 0, all slaves execute the write function, but do not return response messages to the master.

D.4 Modbus Self-Diagnosis

The iQpump drive has a built-in function for self-diagnosing the operations of serial communication interface circuits. The self-diagnosis function connects the communication parts of the send and receive terminals, receives the data sent by the iQpump drive, and checks if communication is being performed normally.

Perform the self-diagnosis function using the following procedure.

1. Turn ON the power supply to the iQpump drive, and set parameter H1-05 (Terminal S7 Function Selection) to 67 (Comm Test Mode).
2. Turn OFF the power supply to the iQpump drive.
3. Perform wiring according to the following diagram while the power supply is turned OFF.
4. Turn ON the terminating resistance. (Turn ON pin 1 on DIP switch 1.)
5. Turn ON the power supply to the iQpump drive again.

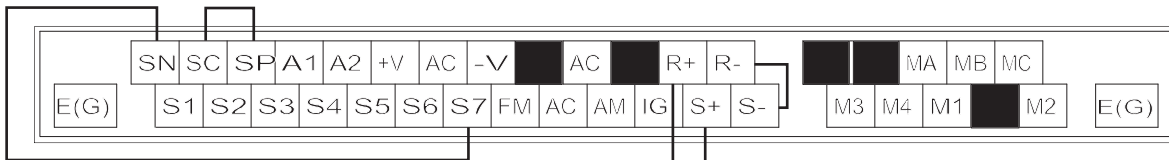

Figure D.8 Communication Terminal Connection for Self -Diagnosis Function

6. During normal self-diagnostic operation, the digital operator displays the frequency reference value. If an error occurs, a CE (Modbus communication error) alarm will be displayed on the digital operator, the fault contact output will be turned ON, and the iQpump drive operation ready signal will be turned OFF.

D.4 Modbus Self-Diagnosis

THIS PAGE INTENTIONALLY BLANK.



Appendix: E

Peripheral Devices

This appendix describes recommended branch short circuit protection and peripheral devices.

E.1 Branch Circuit Short Circuit Protection	228
E.2 Branch Circuit Overload Protection	230
E.3 Peripheral Devices	230
E.4 Third Party Serial Communication Converters	
RS232-RS485 / USB - RS485 Converters	231
E.5 PumpScada Software	233
E.6 Energy Savings Estimation Software	233

E.1 Branch Circuit Short Circuit Protection

The following fuses and/or circuit breakers may be required between the AC power supply and the iQpump drive input terminals L1(R), L2(S), and L3(T) depending on local electrical codes. Use Table E.1 or E.2 when selecting fuses and circuit breakers to comply with NEC codes. Select one of the fuses in Table E.3 or E.4 when selecting semiconductor fuses to provide iQpump drive input I²t protection and comply with UL, CSA, NEC, and CEC branch circuit short circuit protection requirements.

- Fuse Type:** UL designated Time-Delay or Non-Time-Delay Fuse
 Class: CC, J, T, RK1 or RK5
 Designators (typical): KTK, FNQ, FRS, LPJ, LPS, JKS, JN, or JJS
 Voltage Rating: 250 V for drives with 208-240 V input
 600 V for drives with 480 V input
- Circuit Breaker Type:** Inverse Time (MCCB) or Instantaneous Trip (MCP)
 Voltage Rating: 600 V

Table E.1 Recommended Fuse and Circuit Breaker Ratings per NEC (208-240 Vac Input)

Model CIMR-P7U□-107	HP	Input Amps *1 (Continuous Rating)	Output Amps *1 (Continuous Rating)	Fuse Selection Criteria		Circuit Breaker Selection Criteria
				Maximum Time-Delay Fuse Rating (A)	Maximum Non-Time-Delay Fuse Rating (A)	Maximum CB Rating (A)
20P4	0.5/0.75	4.3	3.6	6	12	15
20P7	1	5.5	4.6	8	12	15
21P5	1.5/2	9.4	7.8	15	15	15
22P2	3	13	10.8	20	20	20
23P7	5	20	16.8	30	30	35
25P5	7.5	24	23	40	50	45
27P5	10	37	31	60	80	80
2011	15	53	46.2	80	80	100
2015	20	70	59.4	110	125	125
2018	25	89	74.8	125	150	150
2022	30	98	88	150	150	175
2030	40	120	115	200	200	225
2037	50	180	162	250	250	300
2045	60	212	192	300	300	350
2055	75	237	215	350	350	450
2075	75/100	350	312	450	450	600
2090	125	396	360	600	600	700
2110	150	457	415	700	700	900

*1 Input and Output Amps are based on the Normal Duty (ND) current rating. Consult the Specification section for details on the Heavy Duty (HD) and Normal Duty (ND) ratings.

Table E.2 Recommended Fuse and Circuit Breaker Ratings per NEC (480 Vac Input)

Model CIMR-P7U□-107	HP	Input Amps *1 (Continuous Rating)	Output Amps *1 (Continuous Rating)	Fuse Selection Criteria		Circuit Breaker Selection Criteria
				Maximum Time-Delay Fuse Rating (A)	Maximum Non-Time-Delay Fuse Rating (A)	Maximum CB Rating (A)
40P4	0.5/0.75	2.2	1.8	4	10	15
40P7	1	2.5	2.1	4	10	15
41P5	1.5/2	4.4	3.7	8	12	15
42P2	3	6.4	5.3	10	15	15
43P7	5	9	7.6	15	20	20
44P0	-	10.4	8.7	15	30	20
45P5	7.5	15	12.5	25	30	30
47P5	10	20	17	30	30	40
49P0	15	26	21	45	50	60
4011	20	33	27	45	50	60
4015	25	40	34	60	70	80
4018	30	48	40	70	80	90
4022	-	55	50.4	80	80	100
4024	40	57	52	100	100	125
4030	50	74	67.2	100	100	125
4037	60	85	77	125	125	150
4045	75	106	96	150	150	200
4055	100	134	125	200	200	225
4075	125	172	156	250	250	300
4090	150	198	180	300	300	400
4110	200	264	240	350	350	450
4132	-	286	260	400	400	600
4160	250	334	304	450	450	700
4185	300/350	456	414	600	600	800
4220	400/450	567	515	700	700	1000
4300	500+	743	675	900	900	1200

*1 Input and Output Amps are based on the Normal Duty (ND) current rating. Consult the Specification section for details on the Heavy Duty (HD) and Normal Duty (ND) ratings.

Table E.3 Semiconductor Fuses for drive I2t Protection and Branch Circuit Short Circuit Protection (200V Series)

Drive Model CIMR-P7U□-107	Recommended			Alternate 1			Alternate 2		
	Fuse Mfr.	Model No.	Rating	Fuse Mfr.	Model No.	Rating	Fuse Mfr.	Model No.	Rating
20P4	Ferraz	A60Q12-2	600V, 12A	Ferraz	A070GRB006T13	700V, 6A	Bussmann	FWH-20A14F	500V, 20A
20P7	Ferraz	A60Q12-2	600V, 12A	Ferraz	A070GRB006T13	700V, 6A	Bussmann	FWH-20A14F	500V, 20A
21P5	Ferraz	A60Q15-2	600V, 15A	Ferraz	A70QS25-22F	700A, 25A	Bussmann	FWH-20A14F	500V, 20A
22P2	Ferraz	A60Q20-2	600V, 20A	Ferraz	6,900CPGRC14.51/25	690V, 25A	Bussmann	FWH-25A14F	500V, 25A
23P7	Ferraz	A60Q30-2	600V, 30A	Ferraz	A70QS32-14F	700A, 32A	Bussmann	FWH-45B	500V, 45A
25P5	Ferraz	A50P50-4	500V, 50A	Ferraz	A70QS50-14F	700V, 50A	Bussmann	FWH-80B	500V, 80A
27P5	Ferraz	A50P80-4	500V, 80A	Ferraz	A50QS70-4	500V, 70A	Bussmann	FWH-80B	500V, 80A
2011	Ferraz	A50P80-4	500V, 80A	Ferraz	A50QS100-4	500V, 100A	Bussmann	FWH-100B	500V, 100A
2015	Ferraz	A50P125-4	500V, 125A	Ferraz	A50QS150-4	500V, 150A	Bussmann	FWH-175B	500V, 175A
2018	Ferraz	A50P150-4	500V, 150A	Ferraz	A50QS175-4	500V, 175A	Bussmann	FWH-200B	500V, 200A
2022	Ferraz	A50P150-4	500V, 150A	Ferraz	A50QS200-4	500V, 200A	Bussmann	FWH-200B	500V, 200A
2030	Ferraz	A50P200-4	500V, 200A	Bussmann	FWH-200B	500V, 200A	Bussmann	FWH-225B	500V, 225A
2037	Ferraz	A50P250-4	500V, 250A	Ferraz	A30QS275-4	300V, 275A	Bussmann	170M4610	690V, 315A
2045	Ferraz	A50P300-4	500V, 300A	Ferraz	A30QS350-4	300V, 350A	Bussmann	FWH-350A	500V, 350A
2055	Ferraz	A50P350-4	500V, 350A	Bussmann	FWH-400A	500V, 400A	Bussmann	FWH-450A	500V, 450A
2075	Ferraz	A50P450-4	500V, 450A	Ferraz	A070URD33KI0550	700V, 550A	Bussmann	FWH-500A	500V, 500A
2090	Ferraz	A50P600-4	500V, 600A	Ferraz	A70P600-4	700V, 600A	Bussmann	FWH-600A	500V, 600A
2110	Ferraz	A50P600-4	500V, 600A	Ferraz	A70P700-4	700V, 700A	Bussmann	FWH-700A	500V, 700A

E.2 Branch Circuit Overload Protection

Table E.4 Semiconductor Fuses for drive I²t Protection and Branch Circuit Short Circuit Protection (400V Series)

Table E.4 Semiconductor Fuses for drive I ² t Protection and Branch Circuit Short Circuit Protection (400V Series)									
Drive Model CIMR-P7U□- 107	Recommended			Alternate 1			Alternate 2		
	Fuse Mfr.	Model No.	Rating	Fuse Mfr.	Model No.	Rating	Fuse Mfr.	Model No.	Rating
40P4	Ferraz	A60Q10-2	600V, 10A	Ferraz	A070GRB006T13	700V, 6A	Ferraz	A70QS16-14F	690V, 16A
40P7	Ferraz	A60Q10-2	600V, 10A	Ferraz	A070GRB006T13	700V, 6A	Ferraz	A70QS16-14F	690V, 16A
41P5	Ferraz	A60Q12-2	600V, 12A	Ferraz	6,900CPGRC14.51/25	690V, 25A	Ferraz	A70QS20-14F	690V, 20A
42P2	Ferraz	A60Q15-2	600V, 15A	Ferraz	A70QS25-22F	700V, 25A	Ferraz	A70QS20-14F	690V, 20A
43P7	Ferraz	A60Q20-2	600V, 20A	Ferraz	A70QS20-14F	700V, 20A	Ferraz	A70QS25-14F	690V, 25A
44P0	Ferraz	A60Q30-2	600V, 30A	Ferraz	A70QS32-14F	700V, 32A	Ferraz	A70QS40-14F	690V, 40A
45P5	Ferraz	A60Q30-2	600V, 30A	Ferraz	A70QS32-14F	700V, 32A	Ferraz	A70QS40-14F	690V, 40A
47P5	Ferraz	A60Q30-2	600V, 30A	Ferraz	A70QS40-14F	700V, 40A	-	-	-
49P0	Ferraz	A70P50-4	700V, 50A	Ferraz	A50QS50-4	500V, 50A	Bussmann	FWH-80B	500V, 80A
4011	Ferraz	A70P50-4	700V, 50A	Ferraz	A50QS50-4	500V, 50A	Bussmann	FWH-80B	500V, 80A
4015	Ferraz	A70P70-4	700V, 70A	Ferraz	A50QS80-4	500V, 80A	Bussmann	FWH-100B	500V, 100A
4018	Ferraz	A70P80-4	700V, 80A	Ferraz	A50QS100-4	500V, 100A	Bussmann	FWH-125B	500V, 125A
4022	Ferraz	A70P80-4	700V, 80A	Ferraz	A50QS100-4	500V, 100A	Bussmann	FWH-125B	500V, 125A
4024	Ferraz	A70P100-4	700V, 100A	Ferraz	A50QS125-4	500V, 125A	Bussmann	FWH-125B	500V, 125A
4030	Ferraz	A70P100-4	700V, 100A	Ferraz	A50QS125-4	500V, 125A	Bussmann	FWH-125B	500V, 125A
4037	Ferraz	A70P125-4	700V, 125A	Ferraz	A50QS125-4	500V, 125A	Bussmann	FWH-150B	500V, 150A
4045	Ferraz	A70P150-4	700V, 150A	Ferraz	A50QS150-4	500V, 150A	Bussmann	FWH-175B	500V, 175A
4055	Ferraz	A70P200-4	700V, 200A	Ferraz	A70QS200-4	700V, 200A	Bussmann	FWH-200B	500V, 200A
4075	Ferraz	A70P250-4	700V, 250A	Ferraz	A50QS250-4	500V, 250A	Bussmann	FWH-250A	500V, 250A
4090	Ferraz	A70P300-4	700V, 300A	Ferraz	A50QS300-4	500V, 300A	Bussmann	170M4611	690V, 350A
4110	Ferraz	A70P350-4	700V, 350A	Ferraz	A50P350-4	500V, 350A	Bussmann	170M4611	690V, 350A
4132	Ferraz	A70P400-4	700V, 400A	Ferraz	A70P500-4	700V, 500A	Bussmann	170M5610	690V, 500A
4160	Ferraz	A70P450-4	700V, 450A	Ferraz	A70QS700-4	700V, 700A	Bussmann	FWH-600A	500V, 600A
4185	Ferraz	A70P600-4	700V, 600A	Ferraz	A70QS700-4	700V, 700A	Bussmann	FWH-700A	500V, 700A
4220	Ferraz	A70P700-4	700V, 700A	Bussmann	FWH-800A	500V, 800A	Bussmann	FWH-1000A	500V, 1000A
4300	Ferraz	A70P900-4	700V, 900A	Bussmann	FWH-1000A	500V, 1000A	Bussmann	FWH-1200A	500V, 1200A

E.2 Branch Circuit Overload Protection

All iQpump drive models have built-in UL evaluated motor overload protection. Motor overload protection is also provided in accordance with the NEC and CEC. Additional branch circuit overload protection is not required for single motor applications.

E.3 Peripheral Devices

The following peripheral devices may need to be mounted between the AC power supply and the iQpump drive input terminals R/LI, S/L2, and T/L3.

⚠ CAUTION

Never connect a general LC/RC noise filter to the iQpump drive output circuit.

Never connect a phase-advancing capacitor to the input or output sides, or a surge suppressor to the output side of the iQpump drive. When magnetic contactor is installed between the iQpump drive and the motor, never turn it on or off during operation.

For more details on peripheral devices, contact the manufacturer.

◆ Magnetic Contactor

Mount a surge protector on the coil. When using a magnetic contactor to start and stop the iQpump drive, do not exceed one start per hour.

◆ **AC and DC Reactor**

Install an AC or DC reactor when using models P7U20P4 through P7U2018 and P7U40P4 through P7U4018 on a power supply transformer with a capacity of 600 kVA or more. A reactor improves the input power factor and provides protection to the rectifier circuit within the iQpump drive.

◆ **Noise filter**

Use a noise filter exclusively for the iQpump drive if radio noise generated from the iQpump drive causes other control devices to malfunction.

**E.4 Third Party Serial Communication Converters
RS232-RS485 / USB - RS485 Converters**

The iQpump drive has been tested with these Serial/USB to RS/485 converters listed in this document and approved for use with the PumpScada software. Identical converters can be used but proper communication is not guaranteed.

◆ **RS232 Serial Port to RS485 Converters**

Manufacturer: Telebyte, Inc
Model: Telebyte T285
Website: www.telebyteusa.com



Table E.5 T285 Module DIP Switch Settings

	TD Control	RTS Control	220 Ohm Term	Two-Wire Mode	Four-wire Mode
Mode	SW1	SW2	SW3	SW4	SW5
RS-485 Two-Wire Transmitter enabled by TD	ON	OFF	OFF	ON	OFF

Note: DB25M to DB9F and a serial cable are not included with the converter.

Manufacturer: ATEN
Model: IC485AI
Website: www.aten-usa.com/



IC485AI Module Switch Settings

Switch S1 = TxRTS / RxON

Switch S2 = DCE

Serial Setup: Check Echo Back Suppression option in the serial setup screen.

Note: DB25M to DB9F and the serial cable are not included with the converter.

◆ USB Port to RS485 Converters

Manufacturer: B&B Electronics

Model: USOTL4

Website: www.bb-elec.com



USOTL4 Module Dipswitch Settings

SW1	SW2	SW3	SW4
ON	ON	ON	ON

Note: Refer to the user manual that comes with this module for Windows iQpump driver installation. A USB Cable is not included with the converter.

Manufacturer: Advantech

Model: ADAM-4561

Website: www.advantech.com.tw



ADAM 4561 Module Jumper Settings

Internal
JP1
1-2

Note: Refer to the user manual that comes with this module for Windows iQpump driver installation. A USB Cable is not included with the converter.

Manufacturer: Nudam
Model: ND-6530
Website: www.industrialpc.com



NUDAM ND-6530 Module Dipswitch Settings (located next to USB port)

SW1	SW2
ON	ON

Note: Refer to the user manual that comes with this module for Windows driver installation. A USB Cable is not included with the converter.

E.5 SCADA Software for iQpump Drive (SW.iQp.01)

A complementary version of the SCADA software for the iQpump drive is available for download on our website at <http://iqpump.yaskawa.com>.

E.6 iQpump Drive Energy Savings Predictor with Carbon Footprint Calculation Software (SW.ESP.03)

The iQpump Energy Savings Predictor with Carbon Footprint Calculation Software is used to calculate energy savings and the carbon footprint utilizing iQpump. A complementary version of this software is available for download on our website at <http://iqpump.yaskawa.com>.

E.7 iQpump Drive Harmonics Estimator (SW.HE.04)

The iQpump Drive Harmonics Estimator Software estimates harmonics at the Point of Common Coupling (PCC), utilizing the iQpump drive to select the proper mitigation solution. A complementary version of this software is available for download on our website at <http://iqpump.yaskawa.com>.

THIS PAGE INTENTIONALLY BLANK



Appendix: F

Electromagnetic Compatibility

This section describes the measures necessary to comply with the Electromagnetic Compatibility (EMC) Directive.

F.1 Electromagnetic Compatibility	236
--	------------

F.1 Electromagnetic Compatibility

◆ Introduction

This section describes the measures necessary to comply with the Electromagnetic Compatibility (EMC) Directive. Follow the installation and wiring instructions in this manual to ensure compliance.

Yaskawa products are tested by authorized organizations using the standards listed below:

Product standard: EN 61800-3:1996
EN 61000-3-2; A1, A2, A14:2000

◆ Measures to Ensure Conformity of Installed Yaskawa Drives to EMC Directive

Yaskawa drives are not required to be installed in a switch cabinet.

It is not possible to give detailed instructions for all possible types of installations, therefore this manual provides general guidelines.

All electrical equipment produces radio and line-borne interference at various frequencies. The power leads pass this on to the surrounding environment like an antenna. Connecting an item of electrical equipment (e.g. drive) to a supply without a line filter can allow High Frequency (HF) or Low Frequency (LF) interference to penetrate the power distribution system. The basic countermeasures are isolation of the wiring of control and power components, proper grounding, and shielding of cables.

A large contact area is necessary for low-impedance grounding of HF interference. The use of grounding, straps instead of cables is therefore highly recommended.

Cable shields must be connected with ground clips.

◆ Cable Installation

Measures Against Line-Borne Interference:

Line filter and drive must be mounted on the same metal plate. Mount the two components as close to each other as possible, with cables kept as short as possible (see **Figure F.2**).

Use a power cable with a well-grounded shield. Use a shielded motor cable not exceeding 82 feet (25 m) in length. Arrange all grounds to maximize the end of the lead area in contact with ground (e.g. metal plate).

Use a shielded cable with braided shield and ground the maximum possible area of the shield. It is advisable to ground the shield by connecting the cable to the ground plate with metal clips (see **Figure F.1**).

◆ Recommended EMC Filters

Table F.1 Recommended EMC Filters

Drive Model CIMR-P7U□-107	EMC Filter				
	Model Number	Current Rating	Weight lb. (kg)	Dimensions inches (mm)	NominalHp
208-240 Vac					
20P4	FS5972-10-07	10 A	2.43 (1.1)	5.500 x 13 x 1.875 (141 x 330 x 46)	0.5 / 0.75
20P7					1
21P5					1.5/2
22P2	FS5972-18-07	18 A	2.87 (1.3)	5.500 x 13 x 1.875 (141 x 330 x 46)	3
23P7	FS5973-35-07	35 A	3.09 (1.4)	5.500 x 13 x 1.875 (141 x 330 x 46)	5
25P5					7.5
27P5	FS5973-60-07	60 A	6.61 (3)	8 x 14 x 2.375 (206 x 355 x 60)	10

Drive Model CIMR-P7U□-107	EMC Filter				
	Model Number	Current Rating	Weight lb. (kg)	Dimensions inches (mm)	NominalHp
2011	FS5973-100-07	100 A	10.8 (4.9)	9.3125 x 16 x 3.125 (236 x 408 x 80)	15
2015					20
2018					25
2022	FS5973-130-35	130 A	9.48 (4.3)	3.5315 x 14.40625 x 7 (90 x 366 x 180)	30
2030					40
2037	FS5973-160-40	160 A	13.23 (6)	4.750 x 17.750 x 6.6875 (120 x 451 x 170)	50
2045	FS5973-240-37	240 A	24.25 (11)	5.125 x 24 x 9.4375 (130 x 610 x 240)	60
2055					75
480 Vac					
40P4	FS5972-10-07	10 A	2.43 (1.1)	5.500 x 13 x 1.875 (141 x 330 x 46)	0.5/0.75
40P7					1
41P5	FS5972-18-07	18 A	2.87 (1.3)	5.50 x 13 x 1.875 (141 x 330 x 46)	1.5 / 2
42P2					3
43P7					5
45P5					7.5
47P5					10
49P0 / 4011	FS5972-35-07	35 A	4.63 (2.1)	8.125 x 14 x 1.9375 (206 x 355 x 50)	15
4015	FS5972-60-07	60 A	8.82 (4)	9.250 x 16 x 2.50 (236 x 408 x 65)	25
4018					30
4024 / 4030	FS5972-70-52	70 A	7.5 (3.4)	3 x 13 x 7.250 (80 x 329 x 185)	40 / 50
4037	FS5972-130-35	130 A	10.36 (4.7)	3.5 x 14.375 x 7 (90 x 366 x 180)	60
4045					75
4055					100
4075	FS5972-170-40	170 A	13.23 (6)	4.750 x 17.750 x 6.6675 (120 x 451 x 170)	125
4090	FS5972-250-37	250 A	24.25 (11)	5.125 x 24 x 9.4375 (130 x 610 x 240)	150
4110					200

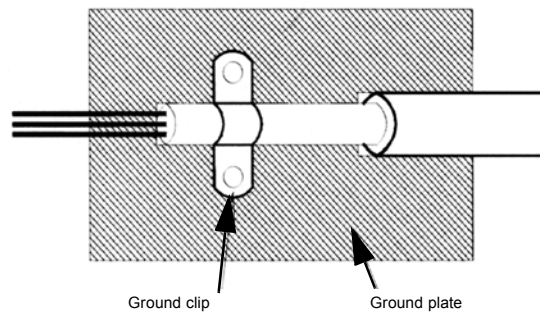

Figure F.1 Grounding Surface Layout

The grounding surfaces must be highly conductive bare metal. Remove any varnish or paint from grounding surfaces.

- Ground the cable shields at both ends.
- Ground the motor of the machine / application.

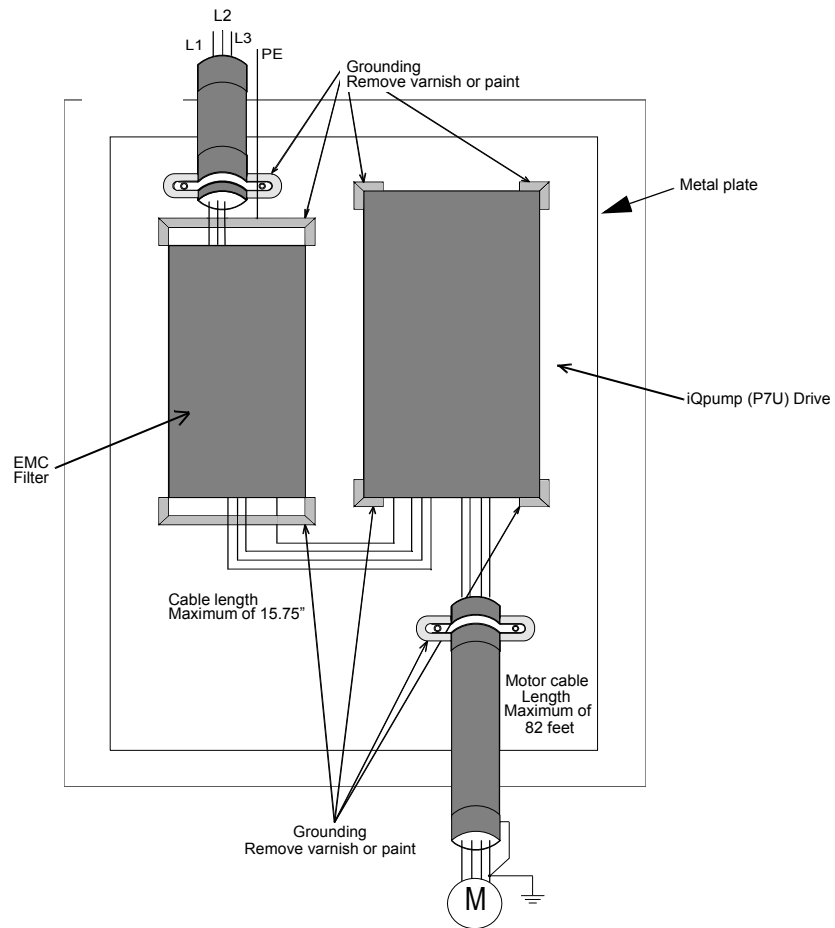

Figure F.2 EMC Filter Layout



Appendix: G

Quick Setup Procedures

This appendix provides quick setup procedures or application examples for common iQpump drive functions.

G.2 Set-up Procedures Included in this Appendix	240
G.3 Well Draw Down Function	241
G.4 Sleep/Sleep Boost Function.	245
G.5 Utility Delayed Start Function	247
G.6 Start Level Function	248
G.7 Low City Pressure or Low Suction Inlet Pressure.	250
G.8 Lube Pump Digital Output for Deep Well Irrigation	251
G.9 iQpump Software Multiplexing Set-up	252
G.10 First In First Out (FIFO) Description	262
G.11 Anti-No Flow Simplified Setup.	263

G.2 Set-up Procedures Included in this Appendix

The following is a summary of set-up procedures and application examples included in this appendix.

- Sleep/Sleep Boost
- Utility Delayed Start Function
- Start Level Software Modification P1-04
- Low City Pressure or Low Suction Inlet Pressure
- Lube Pump Digital Output for Deep Well Irrigation
- MEMOBUS/Modbus Master
- First In First Out (FIFO) Description

G.3 Well Draw Down Function

The Well Draw Down function in parameter P8-01 allows the iQpump drive to deliver water at a constant pressure as long as the ground water remains above the level set in parameter P8-03.

If the ground water level drops to the Water Level Setpoint (P8-03), the iQpump drive will switch from constant pressure regulation to a level regulation and continue to supply water at the recharge rate of the well

If the water level of the well continues to drop, parameter P8-04 will force the iQpump drive to go to sleep. The iQpump drive will remain asleep until the water level rises to the Wake-Up Water Level (P8-05) and will then restart pumping.

Once the water level rises above the Minimum Water Level (P8-04), parameter P8-01 will resume maintaining constant pressure.

◆ Related Parameters

Parameter Number	Parameter Name
d1-01	Setpoint Reference 1
H3-02	Terminal A1 Gain Setting
H3-03	Terminal A1 Bias Setting
P1-05	Start Level Delay Time
P1-06	Minimum Pump Frequency
P2-03	Sleep Delay Time
P4-05	Thrust Bearing Frequency
P8-01	Pressure and Level Control Select
P8-02	Water Level Scaling
P8-03	Water Level Setpoint
P8-04	Minimum Water Level
P8-05	Wake-Up Water Level
P8-06	Level Control Minimum Speed
P8-07	Low Level Detection
P8-09	Low Level Behavior
U1-01	Auto Setpoint Reference
U1-98	Water Level

◆ Well Draw Down Function Set-Up

■ 1. Select Proper Depth-Sensing Transducer

Select a depth-sensing transducer with the transducer element, electrical connections, and connecting cable sealed and safe for liquid submersion. Additionally, the sensor must include a vent tube running the length of the electrical conductors to compensate for changes in barometric pressure to ensure accurate feedback with changing weather patterns.

It is also important to select a depth-sensing transducer with electrical conductors installed by the manufacturer at the length specified by the installer to guarantee that the manufacturer can calibrate the transducer to compensate for any voltage drop across the conductor length.

The maximum length for the pressure transducer leads is 50 m (164 ft); in lengths exceeding 50 m the voltage drop will cause inaccurate feedback. Do not use a standard pressure transducer for level control because many wells exceed 50 m depth and the user must include a transducer calibrated to compensate for the resistance of the wire length from the transducer to the iQpump drive.

Select a range of depth that closely matches the application range. There is not one depth range correct for all applications, especially regarding depth calculations sensitive to small changes in feedback. If the range is too large, accuracy will be compromised.

■ 2. Install Depth-Sensing Pressure Transducer

Separate the pressure transducer leads from the motor leads as the feedback transducer may be sensitive to the iQpump drive motor PWM waveform.

G.3 Well Draw Down Function

■ 3. Connect Level Transducer to the iQpump Drive

Most depth level transducers provide a 4 ~ 20 mA current signal. The A1 Terminal of the iQpump drive is calibrated for voltage-based feedback at 0 ~ 10 Vdc. Installing a burden resistor simplifies the process of converting the current-based feedback to voltage-based feedback.

The burden resistor should be 250 Ohms rated for a minimum of 1/4 W and a tolerance range of less than or equal to 1%. It is possible to use different Ohm values if a burden resistor of exactly 250 Ohms is not available, however the gain and bias settings of the iQpump drive must be adjusted accordingly.

Resistors can be purchased at most electronic stores, online, or through catalogues. Locate the necessary resistor value in **Table G.2** below and match that to the correct gain (H3-02) and bias (H3-03) setting for that value.

Table G.2 Resistor Values and Gain/Bias Settings

Ohms	Gain Setting H3-02	Bias Setting H3-03	Ohms	Gain Setting H3-02	Bias Setting H3-03
230	251.4%	-27.2%	250	231.3%	-25.0%
231	250.3%	-27.1%	251	230.3%	-24.9%
232	249.2%	-26.9%	252	229.4%	-24.8%
233	248.1%	-26.8%	253	228.5%	-24.7%
234	247.1%	-26.7%	254	227.6%	-24.6%
235	246.0%	-26.6%	255	226.7%	-24.5%
236	245.0%	-26.5%	256	225.8%	-24.4%
237	243.9%	-26.4%	257	225.0%	-24.3%
238	242.9%	-26.3%	258	224.1%	-24.2%
239	241.9%	-26.2%	259	223.2%	-24.1%
240	240.9%	-26.0%	260	222.4%	-24.0%
241	239.9%	-25.9%	261	221.5%	-23.9%
242	238.9%	-25.8%	262	220.7%	-23.9%
243	237.9%	-25.7%	263	219.8%	-23.8%
244	236.9%	-25.6%	264	219.0%	-23.7%
245	236.0%	-25.5%	265	218.2%	-23.6%
246	235.0%	-25.4%	266	217.3%	-23.5%
247	234.1%	-25.3%	267	216.5%	-23.4%
248	233.1%	-25.2%	268	215.7%	-23.3%
249	232.2%	-25.1%	269	214.9%	-23.2%

This table is valid for 4-20 mA feedback devices only.
Use 1/4 W resistors with a tolerance of 1%.

The burden resistor is installed onto drive Terminal A1 to AC (analog common) see **Figure G.3**.

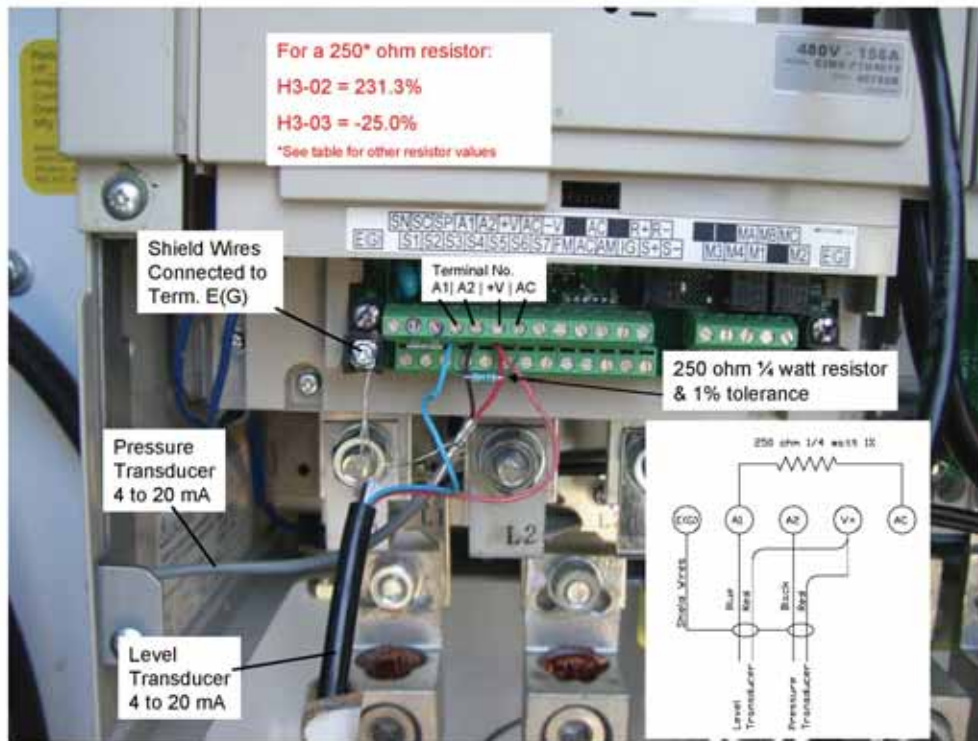

Figure G.3 Terminal Connections with Schematic

■ 4. Connect Standard Pressure Transducer to Terminal A

Terminal A2 is designed to accept both current and voltage-based feedback devices. By default the iQpump drive is set to 4 ~ 20 mA input. If the application uses 4 ~ 20 mA input, no parameter changes are necessary and the previous instruction regarding Terminal A1 in Procedure 3 does not apply.

■ 5. Enable Well Draw Down Function in Parameter P8-01

Setting P8-01 to 1 will automatically change the Terminal A1 input to the Well Draw Down Function and enable the other features for well draw down level control.

■ 6. Set Constant Pressure Setpoint in Monitor U1-01 or Parameter d1-01

In order for the Well Draw Down Function to function properly, the iQpump drive must have a setpoint. U1-01 is the only monitor that will allow parameter value changes without entering into the programming menu. With U1-01, a user can change the setpoints of parameter d1-01, d1-02, d1-03, or d1-04 while the drive is running.

■ 7. Set the Scale of the Level Transducer in Parameter P8-02

Level transducers have range specifications. If the specification is 0 to 50 ft., the user would set parameter P8-02 to 50, which enters the maximum value of the range of the transducer and automatically scales the associated parameters.

■ 8. Set Well Level to be Maintained in Parameter P8-03

The Well Level Setpoint is the water level at which the iQpump drive will stop regulating pressure and start maintaining level. If the water level rises above the level set in P8-03, the iQpump drive will automatically switch back to pressure regulation.

■ 9. Set Well Level to Sleep in Parameter P8-04

When the water level falls to the Minimum Water Level and the Sleep Delay Time set in P2-03 is reached, the iQpump will fall asleep and stop running the pump. The pump will remain asleep until the well level reaches the Wake-Up Water Level set in P8-05.

Note: Delay time is set in parameter P2-03.

■ 10. Set Wake-Up Level in Parameter P8-05

When the water level reaches the Wake-Up Water Level and the on delay timer set in P1-05 expires the drive will automatically begin running again. The Wake-Up Water Level should be greater than the P8-03 (Maintain Level) setting so the drive will automatically go to pressure regulation mode.

Note: Delay time is set in parameter P1-05.

■ 11. Set the Minimum Pump Speed in Level Control in Parameter P8-06

Set the Level Control Minimum Speed should to a level that ensures the pump is moving water out of the well. If it is set to a speed that does not allow water to move, the proportional integral regulator may not drive the well level to sleep, causing damage to the pump or motor. The Minimum Pump Speed is only used in Level Control Mode; the actual minimum speed in Level Mode will be the greater of the values in P1-06, P4-05, and P8-06. If P8-06 is set higher than P1-06 and P4-05, it will only be used while the iQpump drive is in level control mode.

■ 12. Set Low Level Detection Value in Parameter P8-07 and Program the iQpump Drive Response in Parameter P8-09

The Low Level Detection is the level at which the pump is in danger of dry running. Generally this level is a fail safe level and it is desirable to fault the iQpump drive and stop running immediately if the water reaches this level. Low Level Detection can also activate the iQpump fault contacts, which can be used for auxiliary notifications. In P8-09 the iQpump drive can be programmed for one of three responses; No Display, Alarm Only or Fault. Factory default is Alarm Only.

■ 13. Verify Settings and Well Level in Monitor U1-98

The well level can be displayed and observed when the pump is not running by using monitor U1-98, and pressing the Auto button will start the iQpump drive in pressure regulation mode assuming all other parameters for pressure regulation have previously been set-up.

Check U1-98 when the setpoint pressure has been reached and note the level. Depending on the recharge rate of the well, this value will be lower than the level without the pump running.

U1-98 will also indicate if the well recharge rate is at current demand and if the other levels are set appropriately. Check U1-98 periodically over the season of operation to check level variations related to the different times of the year.

G.4 Sleep/Sleep Boost Function

The following is a summary of a set-up procedure and application examples included in this section.

- Sleep/Sleep Boost Function

This function is intended for use with a pressure tank and will boost the set pressure (psi) over the Auto Setpoint Monitor (U1-01) prior to shutdown (sleeping), extending the pump sleep time to reduce cycling and save energy.

◆ Application

Example: Irrigation System

A customer is using a pressure tank within the system to compensate for small leaks in the system and to reduce the pump cycling during very low demand periods.

- System Setpoint = 100 psi
- Transducer Range 4 ~ 20 mA = 300 psi
- Sleep Boost Requirement = 10 psi for 15 s
- Motor FLA = 10 Amps

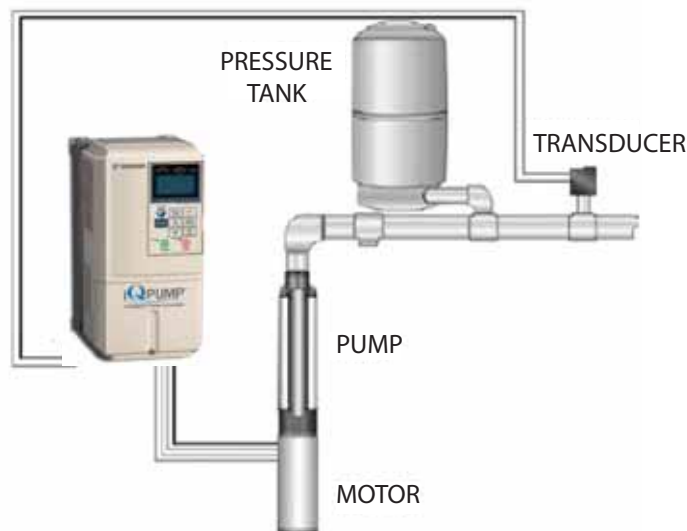

Figure G.4 Irrigation System Example

◆ Related Parameters

The required parameter changes for the Sleep/Sleep Boost Function are as follows:

Parameter	Parameter Name	Setting
E2-01	Motor Rated Current	10 Amps
P1-03	Feedback Device Scaling	300 psi
P2-21	Sleep Boost Level	10 psi
P2-22	Sleep Boost Maximum Time	15 s

Monitor	Monitor Name	Setting
U1-01	Auto Setpoint Reference	100 psi

Note: All other parameters are to remain at the factory default settings.

G.4 Sleep/Sleep Boost Function

Table G.3 Related Parameters <0034>

Parameter No.	Addr. Hex	Parameter Name Digital Operator Display	Description	Setting Range	Factory Setting	Menu Location
P2-21	820	Sleep Boost Level Sleep Boost Lvl	This parameter sets the amount of boost applied to the setpoint just before going to sleep. A setting of 0.0 disables the Sleep Boost function. (Internally limited to 25% of P1-03)	0.0 ~ 6000.0 (system units P1-02)	0.0	Programming
P2-22	821	Sleep Boost Maximum Time Sleep Boost Time	This parameter sets the amount of time the system (feedback) has to reach the “boosted” setpoint. If more than this time elapses, the drive will go to sleep.	1.0 ~ 160.0 s	5.0 s	Programming

◆ Troubleshooting

If the Sleep Boost pressure does not achieve 110 psi before shutting down:

- Ensure that the pump system in use can produce this Sleep Boost psi level.
- Extend the Sleep Boost Time (P2-22) in increments of 5 s. With longer acceleration rates, the Sleep Boost Time may require adjustment.
- The drive will stop the Sleep Boost Cycle when either the boost pressure of 110 psi is achieved and/or when the Sleep Boost Time has expired.

G.5 Utility Delayed Start Function

The following is a summary of a set-up procedure and application examples included in this section.

- Utility Delayed Start Function

The Utility Start Delay function allows multiple iQpump drives to be supplied from the same utility source. Using this function, it is possible to program staggered restart times to eliminate inrush surging on the power source upon restoration of power following a power outage. This function is used in conjunction with either the HOA keypad or an external run command.

◆ Set-Up Example for the Utility Delayed Start Function

Three 150 HP iQpump drives are connected to the same utility pole. The engineering requires that the drives automatically restart on loss of power, however the drives must stagger restart by 30 seconds each to eliminate inrush.

Required Parameter Changes:

Parameter	Drive A	Drive B	Drive C
P4-11	0.5 min	1.0 min	1.5 min

Note: All other parameters are at factory default settings.

◆ Related Parameters

Parameter No.	Addr. Hex	Parameter Name Digital Operator Display	Description	Setting Range	Factory Setting	Menu Location
P4-11	82A	Utility Start Delay Utility Delay	Sets the amount of time the drive will delay starting if a run command is present at power up. A setting of 0.0 disables this function.	0.0 ~ 1000.0 min	0.2 min	Programming

G.6 Start Level Function

The following is a summary of a set-up procedure and application examples included in this section.

- Start Level Function

With the Start Level function, the system starts when the feedback level drops below the start level for the time specified in P1-05. This level also specifies the wake up level when the iQpump drive is in Sleep Mode. If this is set to a negative value, the feedback level must drop this amount below the setpoint.

When parameter P1-04 is set to a positive value, the feedback must drop below that value before the drive will wake up. When parameter P1-04 is set to a negative value, the feedback must drop the P1-04 amount below the setpoint.

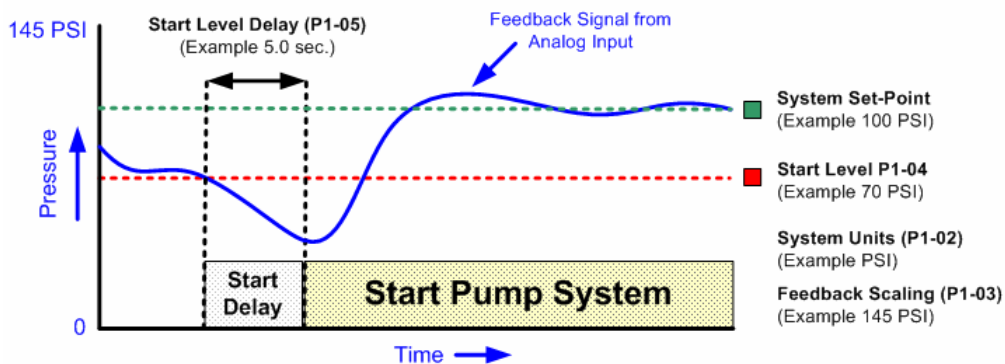

Figure G.5 Start Pump System

In **Figure G.5** above, the system setpoint U1-01 = 100 psi and start level P1-04 = 70 psi and the iQpump drive would allow for a 30 psi pressure draw down before starting. If the setpoint U1-01 is increased to 110 psi, the new draw down pressure is equal to 40 psi (110 psi - 70 psi = 30 psi).

If maintenance of a 30 psi draw down pressure is required, the P1-04 setting would need to increase to 80 psi (110 psi - 80 psi = 30 psi).

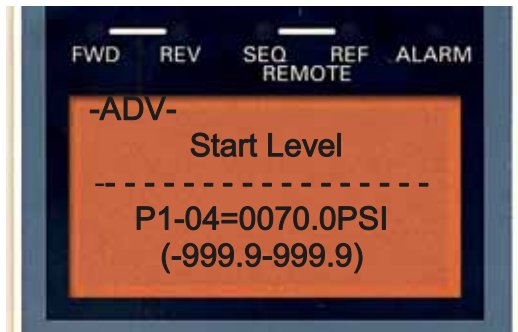

Figure G.6 70 psi

Figure G.6 shows 70 psi Start level for a 30 psi draw down with a setpoint U1-01 = 100 psi.

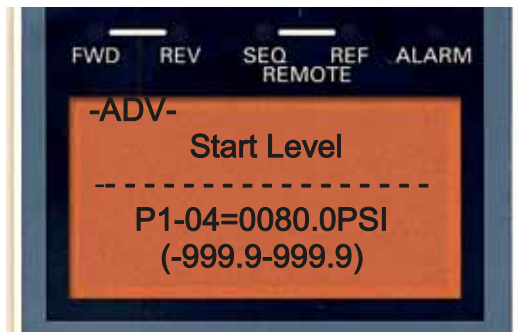

Figure G.7 80 psi

Figure G.7 shows 80 psi Start level for a 30 psi draw down with a setpoint U1-01 = 110 psi.

P1-04 can be programmed using a negative (-) psi value that will represent an absolute delta draw down of pressure from the auto setpoint U1-01. Using the same example in **Figure G.7** to maintain a 30 psi draw down from either 100 psi or 110 psi, then P1-04 = -30 psi.

Using a negative psi start level will maintain the same delta draw down of pressure 30 psi regardless of the auto setpoint U1-01. By using this programming method, it is not necessary to reprogram P1-04 when the auto setpoint U1-01 is adjusted.

To program a negative start level, the far left digit must be showing a “-” sign. This is done in programming mode by highlighting the far left digit and pressing the down arrow on the keypad. When the number zero changes to a negative sign, move the cursor to the far right and enter in the draw down pressure of 30 psi. Refer to **Figure G.7**.

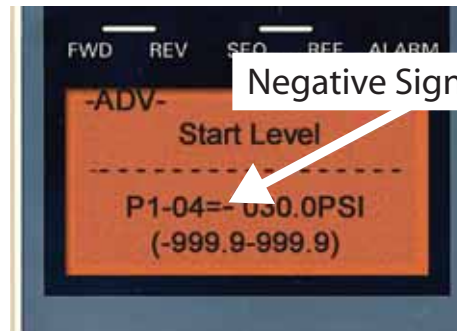

Figure G.8 -30 psi

Figure G.8 shows a -30 psi Drawn Down Pressure with a setpoint U1-01 = 100 psi.

G.7 Low City Pressure or Low Suction Inlet Pressure

The following is a summary of a set-up procedure and application examples included in this section.

- Low City Pressure or Low Suction Inlet Pressure

This function is used with low suction inlet pressure switches on pressure booster systems for buildings that get their main water supply from a municipality. This pressure switch enables and disables the pump system when the inlet supply is at a low demand and when running the pump system in this condition will cause damage.

The inlet pressure switch is wired directly into an iQpump drive using one of the S3-S7 Terminals on the main control board. If the pressure switch is active and sufficient pressure is available, the iQpump drive system will operate normally. If the inlet pressure switch indicates that incoming pressure is too low, the Low City Pressure alarm will be displayed and the iQpump drives will be forced to sleep. Any other iQpump drives staged on in multiplex mode will immediately be de-staged and coast to a stop. All iQpump drives will restart when sufficient pressure returns.

◆ Low City Pressure Application Example

A simple 10 HP Booster Station that has a normally closed pressure switch when municipal city pressure is above 30 psi will shut down after 5 seconds when pressure falls below 30 psi. The pump system will automatically restart when the inlet pressure is above 30 psi for 5 seconds to ensure the inlet pressure is stable.

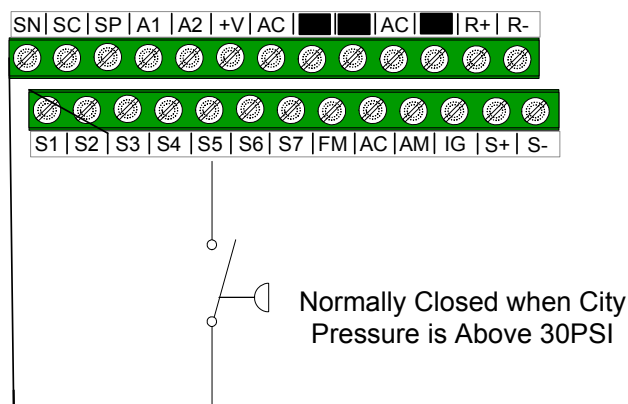

Figure G.9 Pressure Switch

◆ Required Parameter Changes

- H1-03 = 73 (Terminal input S5)
 - P4-21 = 1 (Normally Closed is factory default)
 - P4-22 = 5 seconds
- Note:** All other parameters are at factory default settings.

Parameter No.	Addr. Hex	Parameter Name Digital Operator Display	Description	Setting Range	Factory Setting	Menu Location
P4-21	834	Low City Pressure Input Select Low City In Sel	Selects the type of pressure switch connected to the “Low City Pressure” digital input (H1-0x = 73). 0: Normally Open (closed indicates the “Low City Pressure” condition) 1: Normally Closed (open indicates the “Low City Pressure” condition)	0 or 1	1	Programming
P4-22 ◆	835	Low City Pressure Input Delay Low City Delay	Sets the amount of time a “Low City Pressure” condition needs to be present before the drives will stop. Also sets the amount of time that the pressure needs to be adequate before the drive system will restart.	1 ~ 1000 s	10	Programming

Table G.4 Added Multi-Function Output Setting

Setting	Description	V/f
73	Low City Press Indicates that sufficient / insufficient pressure is present on the inlet to the pump. Used mainly for pressure booster stations.	,

G.8 Lube Pump Digital Output for Deep Well Irrigation

The following is a summary of a set-up procedure and application examples included in this section.

- Lube Pump Digital Output for Deep Well Irrigation example

The iQpump drive uses a programmable internal timer that allows for a normally open digital output to close before the pump starts in Auto or Hand mode. This activates a solenoid valve and allows water to flow to pre-lube the bearings.

This digital output setting is used in vertical turbine well pumps known as a Lineshaft turbine pumps. Lineshaft turbine pumps have a motor located on the well head with a line shaft supported by shaft bearings running down the discharge column pipe to the pump. Water-lubricated line shaft bearings rely on water pumped through the column pipe for cooling and lubrication. When the water table is very shallow, water in the column pipe reaches the bearing almost immediately. When the water table is deeper, it can take several seconds for water to reach the uppermost bearings, which will fail prematurely if they are allowed to spin for even a few seconds without lubrication.

This type of installation will normally have some type of pre-lubrication system that allows water to run down the shaft and lubricate the top bearings before the pump starts. The most common pre-lube systems are from a pressurized header or water storage tank.

Note: Check the voltage and maximum current rating on the digital outputs before wiring to terminals.

◆ Deep Well Irrigation Application Example

A turbine pump requires that a solenoid valve is activated for 15 seconds to pre-lubricate the line shaft bearings before the pump starts. Digital outputs M1-M2 will close at the start to energize the solenoid and allow water to flow.

Lube Pump: The lube pump function will operate when the iQpump drive is accelerating from zero speed. Instead of starting, the drive will remain base-blocked at zero speed until the lube pump timer configured by Parameter P4-23 expires. Whenever the lube pump timer is timing (after a start or restart), the Lube Pump digital output (H2-0x = 55) will be energized. Setting Parameter P4-23 to 0.0 disables the lube pump feature

◆ Required Parameter Changes

- H2-01 = 55 (Digital Outputs M1-M2)
- P4-23 = 15 s

Note: All other parameters are at factory default settings.

Table G.5 Related Parameters

Parameter No.	Addr. Hex	Parameter Name Digital Operator Display	Description	Setting Range	Factory Setting	Menu Location
P4-23	836	Lube Pump Delay Timer Lube Pump Time	Sets the amount of time the drive output will be delayed and the Lube Pump digital output (H2-0x = 55) will be energized. A setting of 0.0 will disable this feature	0.0 ~ 300.0 s	0.0	Programming

Table G.6 Added Multi-Function Output Setting

Setting	Description	V/f
55	Lube Pump This will energize for the time set in parameter P4-23 each time the drive is supposed to start. The drive will delay starting for P4-23 time.	,

Table G.7 Alarm

Alarm Display	Description
Lube Pump Running	The drive is delaying the start of the motor and the Lube Pump digital output is energized.

G.9 iQpump Software Multiplexing Set-up

The following is a summary of a set-up procedure and application examples included in this section.

- iQpump Software Multiplexing

◆ Wiring the iQpump Drive RS-485 Network Connections

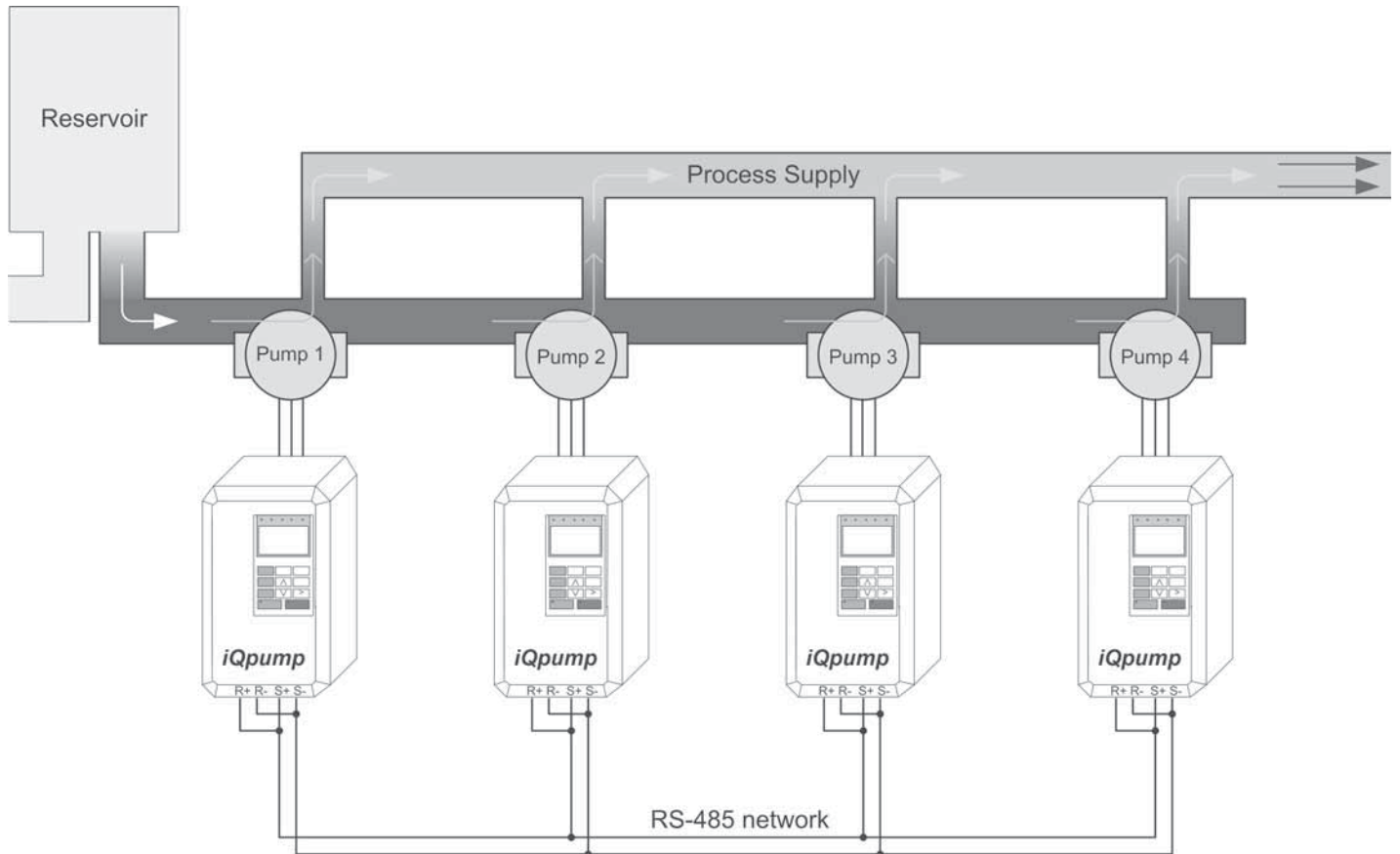

Figure G.10 System Overview

Perform the following steps to make the RS-485 network connections between all iQpump drives that will be multiplexed:

Note: These steps are performed after all other physical and electrical installation procedures are completed. Refer to TM.iQp.06 iQpump User Manual.

1. Jumper terminals (**R+ to S+**) and jumper terminals (**R- to S-**) terminals on each individual iQpump drive according to **Figure G.11**.

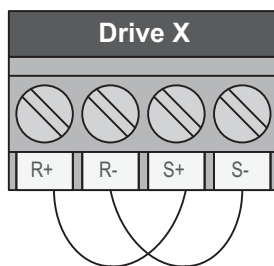

Figure G.11

2. Use shielded communication cable for steps 3 and 4 to connect the iQpump drives in a daisy chain manner according to **Figure G.12**.
3. Daisy chain the **(R+ to S+)** terminals between each iQpump drive.
4. Daisy chain the **(R- to S-)** terminals between each iQpump drive.

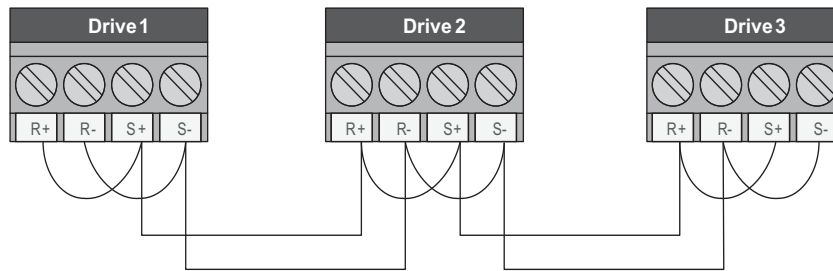

Figure G.12

◆ Setting the iQpump Drive Networking Parameters

1. Set parameter H5-01, Serial Node Address, on each iQpump drive.

Note: For optimal performance, use consecutive numbers starting from 1. Parameter setting H5-01 must be unique for each iQpump drive.

Drive 1	Drive 2	Drive 3
H5-01 = 1	H5-01 = 2	H5-01 = 3

2. Set parameter P9-25, Highest Node Adr, on each iQpump drive.

Note: For optimal performance, set to highest H5-01 value. This setting must be the same for all the iQpump drives on the network.

Drive 1	Drive 2	Drive 3
P9-25 = 3	P9-25 = 3	P9-25 = 3

3. Set P1-01 to 3 (MEMOBUS/Modbus Network) on all the iQpump drives.

Drive 1	Drive 2	Drive 3
P1-01 = 3	P1-01 = 3	P1-01 = 3

4. Cycle main power to all networked iQpump drives.

Note: The H5-01 setting will not take effect until power is cycled to the iQpump drive and may cause communication errors and unexpected behavior.

◆ Verifying the iQpump Drive Network Communications

Access monitor U1-67, Network Activity, and verify that:

- No iQpump drives have a value of 0 <->
- All iQpump drives are receiving valid data indicated by a regular change in the monitor value.
- At least one iQpump drive has the unit <M>, while the others have the unit <+>.

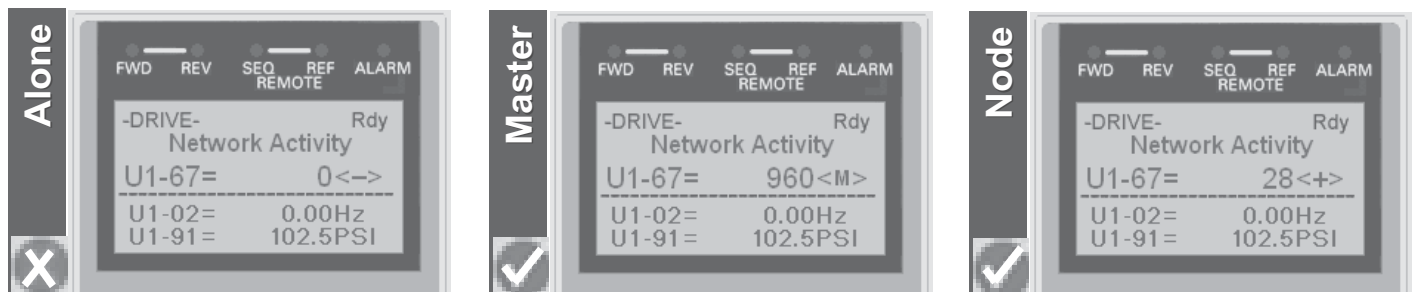

Figure G.13 Example Digital Operator Displays for Verifying Correct Communication

G.9 iQpump Software Multiplexing Set-up

An iQpump drive displays U1-67 = 0 <->:

- Check physical connections.
- Verify the H5-XX serial communication settings.
- Confirm the P9-25 and P9-27 settings on all the iQpump drives. P9-25 should be set to the highest H5-01 address and at least one iQpump drive should have P9-27 = 0.
- Cycle main power.

◆ iQpump Drive Multiplexing Principle

Always observed by system:

- New iQpump drives start as Lead and run in PI mode
- Only the Lead iQpump drive can request staging and de-staging
- Staging will start a new Lead iQpump drive and make the old Lead iQpump drive into a Lag iQpump drive
- De-staging will stop the current Lead iQpump drive and restore the previous iQpump drive as the Lead iQpump drive.

◆ iQpump Drive Multiplexing Parameters

- To customize staging, adjust parameters P9-08 to P9-11 for each iQpump drive.
- To customize de-staging, adjust parameters P9-12 to P9-15 for each iQpump drive.
- P9-29, Net Start Delay, delays the selection of the first lead iQpump drive to allot time for all relevant iQpump drives to be put on Auto mode.

Parameter No.	Addr. Hex	Parameter Name Digital Operator Display	Description	Setting Range	Factory Setting	Menu Location
P9-29 ◆	089C	Net Start Delay Net Start Delay	After the first drive on the network has been put on Auto mode, the network will wait this amount of time before selecting and starting the Lead Drive.	0.0 ~ 60.0 s	2.0 s	Programming

- P9-01, Lead Drive Select

Parameter No.	Addr. Hex	Parameter Name Digital Operator Display	Description	Setting Range	Factory Setting	Menu Location
P9-01	0880	Lead Drive Selection Lead Drive Sel	Specifies how the next Lead Drive is selected 0: Next Available (operates like a round-robin) 1: Lowest Runtime (iQpump drive with lowest U1-13)	0 or 1	1	Programming

- P9-23, Max Pumps Running

Parameter No.	Addr. Hex	Parameter Name Digital Operator Display	Description	Setting Range	Factory Setting	Menu Location
P9-23 ◆	0896	Max Number of Running Pumps MaxPumps Running	Limits the maximum number of pumps that can run on the system simultaneously.	1 ~ 16	16	Programming

- P9-05, Lag Drive Mode

Parameter No.	Addr. Hex	Parameter Name Digital Operator Display	Description	Setting Range	Factory Setting	Menu Location
P9-05	0884	Lag Drive Mode Lag Drive Mode	Determines how the Lag Drives function. 0: Fixed Speed - Runs at Lag Fixed Speed (P9-06) after Lag Fixed Speed Delay (P9-07) expires. 1: PI Regulation - Regulates independently but does not control staging/de-staging. 2: Turn Off - Drive cannot run as Lag.	0 or 1	0	Programming

◆ iQpump Drive Run Order

U1-62, Running Queue No:

- Shows the position in the iQpump MEMOBUS running queue
- Set U1-62 to 0 for pumps that are not running
- Set U1-62 to 1 on the first pump that came on and is still running.
- Set U1-62 to 2 on the second pump that came on and is still running.
- Set U1-62 to the number of pumps running for the current Lead iQpump drive.

◆ Multiplex Status Display

Network State	Display
Drive is not able to accept commands from the iQpump Memobus network because the drive is not in Auto Mode run.	
Drive is in Auto Mode and waiting for a run command from the iQpump Memobus network.	
Drive is in Auto Mode, Lead operation and is currently regulating the system using PI control.	
Drive is in Auto Mode, Lag operation and is holding the speed at the time it made the switch from being a lead drive to a lag. Speed is held until P9-07 time expires. U1-01 will display Frequency instead of System Units.	
Drive is in Auto Mode, Lag operation and is running at the speed set in P9-06. U1-01 will display Frequency instead of System Units.	

Figure G.14 Multiplexing Status Display

◆ PI Feedback via Network

The Network PI Feedback comes from an iQpump drive on the network with a valid analog PI feedback source and can be used as the primary or secondary feedback source for a networked iQpump drive.

Parameter No.	Addr. Hex	Parameter Name Digital Operator Display	Description	Setting Range	Factory Setting	Menu Location
P9-02	0881	Feedback Source Feedback Source	Defines which signal to use for PI Feedback when P1-01 = 3. 0: Analog Only 1: Ana->Net, No Alarm. 2: Ana->Net, Alarm 3: Network Only Setting has no effect when P1-01 = 3.	0 ~ 3	0	Programming

- Set P9-02 to 0 if an iQpump drive has an analog PI feedback device installed and switching to network as a back-up is not desired.
- if an iQpump drive has an analog PI feedback device installed and the network PI feedback is considered as a back-up, set P9-02 to 1 for no alarm message when switched and set P9-02 to 2 for an alarm.
- Set P9-02 to 3 if an iQpump drive has no analog PI feedback device installed and relies solely on the analog PI feedback of another networked iQpump drive.

Note: Connect an analog PI feedback device to each iQpump drive for best performance.

◆ MEMOBUS Networking Quick Start Guide

Table G.8 Related Parameters

Parameter No.	Addr. Hex	Parameter Name Digital Operator Display	Description	Setting Range	Factory Setting	Menu Location
H5-01	0425	Drive Node Address Serial Com Adr	Selects drive station node number (address) for Terminals R+, R-, S+, S-. Note: An address of "0" disables serial com. Drive power must be cycled before the changes will take effect. *Range is dependent on P9-25, if P1-01 = 3. <0034>	0 to 20*	1F	Programming
P1-01	0600	Pump Mode Pump Mode	Select type of control operation. 0: Drive Only (Simplex) 1: Drive + 1 Pump 2: Drive + 2 Pumps 3: MEMOBUS network <0034>	0 to 3	0	Programming
P9-01	0880	Lead Drive Selection Lead Drive Sel	Specifies how the next Lead Drive is selected. 0: Next Available 1: Lowest Runtime	0 or 1	1	Programming
P9-02	0881	Feedback Source Feedback Source	Defines which signal to use for PI Feedback when P1-01 = 3. 0: Analog Only 1: Ana->Net, No Alarm. 2: Ana->Net, Alarm 3: Network Only Setting has no effect when P1-01 = 3.	0 ~ 3	0	Programming
P9-03 ◆	0882	Alternation Time Alternation Time	Specifies the time for a drive to request alternation, influenced by the Alternation Mode P9-04. The alternation feature is disabled when this parameter is set to 0.	0 ~ 1000 h	24 h	Programming
P9-04	0883	Alternation Mode Alternation Mode	Determines how alternation is performed: 0: FIFO Auto 1: FIFO Forced 2: LIFO	0 ~ 2	0	Programming
P9-05	0884	Lag Drive Mode Lag Drive Mode	Determines how the lag drives function. 0: Fixed Speed - Runs at the P9-06 setting. 1: PI Regulation - Uses PI to determine speed.	0 or 1	0	Programming
P9-06 ◆	0885	Lag Fixed Speed Lag Fixed Speed	When the drive changes from a lead to a lag and P9-05 = 0, the drive will run at this speed after P9-07 delay time expires.	0.0 ~ 120.0 Hz	55.0 Hz	Programming
P9-07 ◆	0886	Lag Fixed Speed Delay Lag Fixed Spd Dly	When the drive changes from a lead to a lag and P9-05 = 0, this time specifies how long before the drive runs at the P9-06 speed.	0 ~ 1000 s	5 s	Programming
P9-08	0887	Add Pump Mode Add Pump Mode	Selects the detection method for staging a new pump: 0: Output Frequency 1: Feedback 2: Feedback + Fout	0 ~ 2	0	Programming
P9-09 ◆	0888	Add Freq Level Add Freq Lvl	When P9-08 = 0 and the output frequency rises above this level for the time set in P9-11, the lead drive will request for a new lead drive through the iQpump MEMOBUS Network. When P9-08 = 2 and the output frequency rises above this level the delta feedback (setpoint - feedback) has exceeded the level set in P9-10 for the time set in P9-11, the lead drive will request for a new lead drive through the iQpump MEMOBUS network.	0.0 ~ 120.0 Hz	56.0 Hz	Programming
P9-10 ◆	0889	Add Delta Level Add Delta Lvl	When P9-08 = 1 and the delta feedback (setpoint - feedback) has exceeded this level for the time set in P9-11, the lead drive will request for a new lead drive through the iQpump MEMOBUS Network. When P9-08 = 2 and the delta feedback (setpoint - feedback) has exceeded this level and the output frequency is above P9-09 for the time set in P9-11, the lead drive will request for a new lead drive through the iQpump MEMOBUS network.	0 ~ 6000.0 (system units P1-02)	0.0 (system units P1-02)	Programming
P9-11 ◆	088A	Add Delay Time Add Dly Time	Delay time before a new lead drive is added to the system.	0 ~ 3600 s	10 s	Programming
P9-12	088B	Remove Pump Mode Remove Pump Mode	Selects the detection method for de-staging to the previous lead pump: 0: Output Frequency 1: Feedback 2: Feedback + Fout	0 ~ 2	0	Programming

Parameter No.	Addr. Hex	Parameter Name Digital Operator Display	Description	Setting Range	Factory Setting	Menu Location
P9-13 ◆	088C	Remove Freq Level Remove Freq Lvl	When P9-12 = 0 and the output frequency drops below this level for the time set in P9-15, the lead drive will request to be removed from the system through the iQpump MEMOBUS network. When P9-12 = 2 and the output frequency drops below this level and the delta feedback (feedback - setpoint) has exceeded the level set in P9-14 for the time set in P9-15, the lead drive will request to be removed from the system through the iQpump MEMOBUS network.	0.0 ~ 120.0 Hz	40.0 Hz	Programming
P9-14 ◆	088D	Remove Delta Level Remove Delta Lvl	When P9-12 = 1 and the delta feedback (feedback - setpoint) has exceeded this level for the time set in P9-15, the lead drive will request to be removed from the system through the iQpump MEMOBUS network. When P9-12 = 2 and the delta feedback (feedback - setpoint) has exceeded this level and the output frequency is below P9-13 for the time set in P9-15, the lead drive will request to be removed from the system through the iQpump MEMOBUS network.	0 ~ 6000.0 (system units P1-02)	0.0 (system units P1-02)	Programming
P9-15 ◆	088E	Remove Delay Time Remove Dly Time	Delay time before the lead drive is removed from the system.	0 ~ 3600 s	10 s	Programming
P9-16 ◆	088F	Stabilization Time Stabilization Time	Time used to stabilize the system when a pump is staged or de-staged. Lead-lag control and pump protection is suspended during this time.	0 ~ 3600 s	3 s	Programming
P9-17 ◆	0890	Setpoint Modifier Set-pt Modifier	System Setpoint is incremented with this value depending on the number of pumps running. Pump 1: Setpoint Pump X: Setpoint + {(X-1) (P9-17)}	-6000.0 ~ 6000.0 (system units P1-02)	0.0 (system units P1-02)	Programming
P9-18 ◆	0891	High Feedback Quick De-Stage High FB De-stage	Determines the feedback level to trigger a quick de-stage, set as a percentage of parameter P1-09. The quick de-stage ignores parameters P9-12 to P9-15 and only uses an internal 2 second delay.	0.0 ~ 100.0%	90.0%	Programming
P9-19 ◆	0892	Alternation Unit Alternation Unit	Selects the unit for P9-03 0: Hours (H) 1: Minutes (min)	0 ~ 1	0	Programming
P9-20	0893	Allow Network Run Allow Net Run	Specifies when a network run command is allowed: 0: Always 1: First / Alternation 2: First Only 3: Alternation Only	0 ~ 3	0	Programming
P9-21 ◆	0894	Run Priority Run Priority	Sets the Lead Drive selection priority overriding the P9-01 selection. If multiple drives have the lowest P9-21 value, then P9-01 determines which drive becomes the Lead.	1 ~ 16	8	Programming
P9-22 ◆	0895	System Fault Retry System Flt Retry	Determines the number of times the iQpump MEMOBUS Network will allow automatic restarts of system faults. The drive uses parameter L5-03 in determining when to attempt a system fault restart. For proper operation, this parameter should be set the same for all network drives.	0 ~ 10	5	Programming
P9-23 ◆	0896	Max Number of Running Pumps MaxPumps Running	Limits the maximum number of pumps that can run on the system.	1 ~ 16	16	Programming
P9-24 ◆	0897	Lead Swap @ Sleep Lead Swap @ Sleep	When the Lead drive has been asleep for this amount of time and there is another drive available with a lower P9-21, then this drive will request for a swap. A setting of 0 disables this function.	0 ~ 7200 s	0 s	Programming
P9-25	0898	Highest Node Address Highest Node Adr	Defines the highest possible node address in the MEMOBUS network. To yield optimal network performance, it is recommended to set the serial communication address H5-01 starting from 01h and then consecutively up to the last drive and then setting this parameter to that H5-01 address.	02 h ~ 10 h	08 h	Programming
P9-26	0899	Master Time-Out Master Time-Out	Sets the minimum amount of time that the slave drives will wait for a message from the master before performing the action set in P9-27.	3.0 ~ 10.0 s	4.0 s	Programming
P9-27	089A	Network Recovery Network Recovery	When no messages are received from the master for the time set in P9-26, the slave drive will act according to this setting: 0: Automatic - drive will attempt to assume master functionality. 1: Slave/Resume - drive will continue running when the master is lost and will wait for a master to come on-line. 2: Slave/Stop - drive will stop running when the master is lost and will wait for a master to come on-line. 3: Fault MSL - fault the drive with an MSL (Master Lost).	0 ~ 3	0	Programming
P9-28	089B	NETSCAN Alarm Time NETSCAN Alrm Time	Sets the amount of time that the slave drives will wait for a message from the master before displaying a NETSCAN alarm.	1.0 ~ 10.0 s	2.0 s	Programming

G.9 iQpump Software Multiplexing Set-up

Parameter No.	Addr. Hex	Parameter Name Digital Operator Display	Description	Setting Range	Factory Setting	Menu Location
P9-29 ◆	089C	Net Start Delay Net Start Delay	After the first drive on the network has been put on Auto mode, the network will wait this amount of time before selecting and starting the Lead Drive.	0.0 ~ 60.0 s	2.0 s	Programming

◆ Application Examples

■ Simple Duplex System

A customer requires a duplex system with the following capabilities:

- Control the system pressure using 2 iQpump drives (no PLCs).
- Alternate iQpump drives everyday to even out the pump wear.
- Toggle switch for Run command.
- Each iQpump drive will have its own feedback transducer and because of shut-off valves, the network feedback as a back-up should not be used.
- Pump is at optimal running speed when running at fixed speed is 54.0 Hz.
- Setpoint is 100 psi, feedback scale is 145 psi, start level is 80 psi.

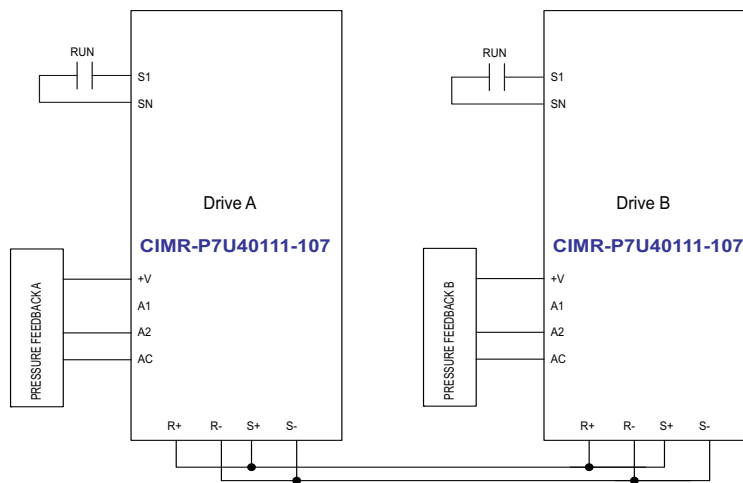

Figure G.15 Simplified Wiring Diagram

Related Parameters for Simple Duplex System Example

Description	Drive A	Drive B
Run Source: 1 = Terminals	b1-02 = 1	b1-02 = 1
Node Address	H5-01 = 1	H5-01 = 2
Highest Node Address	P9-25 = 2	P9-25 = 2
Pump Mode: 3 = Network	P1-01 = 3	P1-01 = 3
Feedback Source: 0 = Analog	P9-02 = 0	P9-02 = 0
Lag Fixed Speed	P9-06 = 54.0 Hz	P9-06 = 54.0 Hz
Setpoint	U1-01 = 100 psi	U1-01 = 100 psi
Start Level	P1-04 = 80 psi	P1-04 = 80 psi

* All other multiplexing and alternation parameters are at default settings.

■ Duplex System with Fine Tuning

The customer would like to run the second drive for 10~20 seconds at minimum speed then shut it off, letting the first drive run at maximum. This will then run the second drive again and the cycle will repeat. The customer must also account for system losses when running both pumps by boosting the setpoint by 5 psi. In the event that the pressure exceeds 125 psi, the second drive should de-Stage if both drives are running. If the pressure exceeds 140 psi, a high feedback fault should occur and stop the drive.

- Multiple methods of handling the pump cycling problem:
 - Lower the lag fixed speed (P9-06)
 - Decrease the lag fixed speed delay (P9-07)
 - Increase the staging frequency level (P9-09)
 - Increase the staging delay time (P9-11)
 - Increase the de-staging delay time (P9-15)
 - Increase the stabilization time (P9-16)
- Increase both the Add Freq Level and Add Dly Time.

Related Parameters for Duplex System with Fine Tuning Example

Description	Drive A	Drive B
Run Source: 1 = Terminals	b1-02 = 1	b1-02 = 1
Node Address	H5-01 = 1	H5-01 = 2
Highest Node Address	P9-25 = 2	P9-25 = 2
Pump Mode: 3 = Network	P1-01 = 3	P1-01 = 3
Feedback Source: 0 = Analog	P9-02 = 0	P9-02 = 0
Lag Fixed Speed	P9-06 = 54.0 Hz	P9-06 = 54.0 Hz
Setpoint	U1-01 = 100 psi	U1-01 = 100 psi
Start Level	P1-04 = 80 psi	P1-04 = 80 psi
High Feedback Level	P1-09 = 140 psi	P1-09 = 140 psi
High Feedback Quick De-Stage	P9-18 = 89.3%	P9-18 = 89.3%
Setpoint Modifier	P9-17 = 5.0 psi	P9-17 = 5.0 psi
Add Drive Frequency Level	P9-09 = 59.0 Hz	P9-09 = 59.0 Hz
Add Drive Delay	P9-11 = 12.0 s	P9-11 = 12.0 s

* All other multiplexing and alternation parameters are at default settings.

■ Duplex System with Jockey Pump

A customer requires a pump system with the following requirements:

- One small pump (the Jockey pump) would run the system during off-peak times.
- Two larger pumps would run the system when the demand is higher.
- The Jockey pump should not run when the two larger pumps are running.
- Pump wear is still an issue, but it is expected that the small pump will run longer hours and will always run first after a loss of power.
- The feedback scale is 145 psi.
- There is only one feedback transducer in the system.

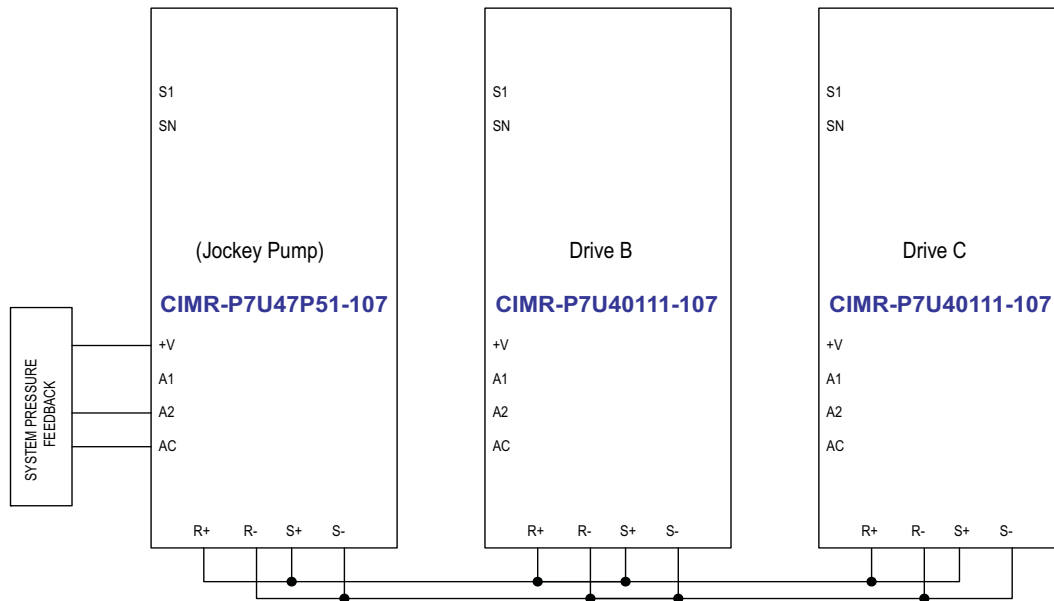

Figure G.16 With Jockey Pump Wiring Diagram

Related Parameters for Duplex System with Jockey Pump Example

Description	Jockey Pump	Drive C	Drive D
Node Address	H5-01 = 1	H5-01 = 2	H5-01 = 3
Highest Node Address	P9-25 = 3	P9-25 = 3	P9-25 = 3
Pump Mode: 3 = Network	P1-01 = 3	P1-01 = 3	P1-01 = 3
Feedback Source: 0 = Analog, 3 = Network	P9-02 = 0	P9-02 = 3	P9-02 = 3
Lag Drive Speed: 0 = Always, 2 = Turn Off	P9-05 = 2	P9-05 = 0	P9-05 = 0
Allow Net Run: 0 = Always, 2 = First Only	P9-20 = 2	P9-20 = 0	P9-20 = 0
Run Priority	P9-21 = 7	P9-21 = 8	P9-21 = 8
Lead Swap @ Sleep	P9-24 = 0	P9-24 = 1200 s	P9-24 = 1200 s
Setpoint	U1-01 = 100 psi	U1-01 = 100 psi	U1-01 = 100 psi
Start Level	P1-04 = 80 psi	P1-04 = 80 psi	P1-04 = 80 psi

* All other multiplexing and alternation parameters are at default settings.

■ **Triplex System**

A customer who currently runs a duplex system would like to retrofit an existing triplex system with the following requirements:

- Three similarly sized pumps would run the system.
- A maximum of two iQpump drives should be running at any point; the third iQpump drive is a back-up.
- Alternation should only happen when pumps are not running (sleeping).
- If one of the analog pressure feedback transducers should fail, read from a working one and notify the customer of the failure by the alarm display.
- Setpoint is 90 psi, feedback scale is 145 psi, start level is 75 psi.

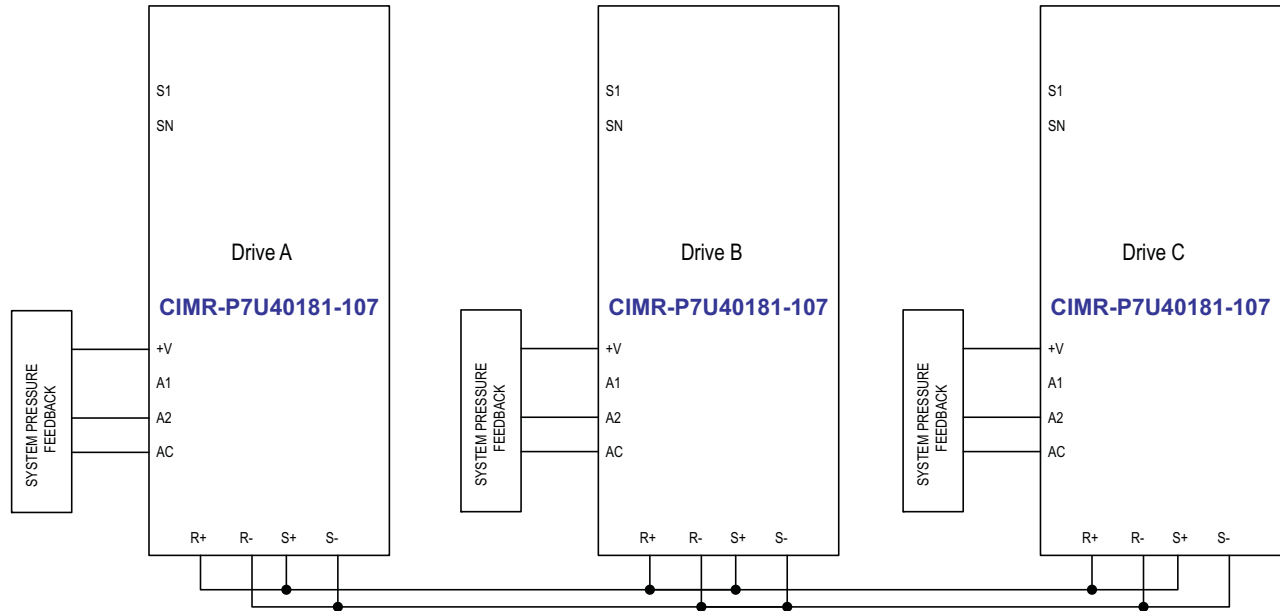

Figure G.17 Triplex System Wiring Diagram

Related Parameters for Triplex System Example

Description	Drive A	Drive B	Drive C
Node Address	H5-01 = 1	H5-01 = 2	H5-01 = 3
Highest Node Address	P9-25 = 3	P9-25 = 3	P9-25 = 3
Pump Mode: 3 = Network	P1-01 = 3	P1-01 = 3	P1-01 = 3
Feedback Source: 2= Analog ->Net, with Alarm	P9-02 = 2	P9-02 = 2	P9-02 = 2
Alternation Mode: 3 = FIFO @ Sleep	P9-04 = 3	P9-04 = 3	P9-04 = 3
Maximum Running Pumps	P9-23 = 2	P9-23 = 2	P9-23 = 2
Setpoint	U1-01 = 90 psi	U1-01 = 90 psi	U1-01 = 90 psi
Start Level	P1-04 = 75.0 psi	P1-04 = 75.0 psi	P1-04 = 75.0 psi

* All other multiplexing and alternation parameters are at default settings.

G.10 First In First Out (FIFO) Description

The following is a summary of a set-up procedure and application examples included in this section.

- FIFO Description

◆ iQpump Drive Alternation Parameters

■ Definitions

- First Drive: U1-62 = 1
 - Last Drive: U1-62 = number of pumps running (Lead iQpump drive)
 - FIFO: First In, First Out - First iQpump drive is alternated
 - LIFO: Last In, First Out - Lead iQpump drive is alternated
- Note:** In either FIFO or LIFO, the replacement iQpump drive always becomes the new Lead iQpump drive

■ Related Parameters

Parameter No.	Addr. Hex	Parameter Name Digital Operator Display	Description	Setting Range	Factory Setting	Menu Location
P9-03 ◆	0882	Alternation Time Alternation Time	Specifies the time for a drive to request alternation, influenced by the Alternation Mode P9-04. The request to alternate is made after this time expires. Active on the First Drive for FIFO modes, and cumulative on the Lead drives for LIFO mode.	0 ~ 1000 h	24 h	Programming
P9-04	0883	Alternation Mode Alternation Mode	Determines how alternation is performed: 0: FIFO Auto: first iQpump drive is removed and there is no replacement unless it is the only iQpump drive 1: FIFO Forced: first iQpump drive is removed and a new Lead iQpump drive is brought on 2: LIFO: Lead iQpump drive is alternated with a new Lead iQpump drive 3: FIFO at Sleep: first iQpump drive is removed only when going to sleep	0 ~ 2	0	Programming

Parameter No.	Addr. Hex	Parameter Name Digital Operator Display	Description
U1-68	0009C	Time to Alternate Time to Alternate	Time remaining before a drive requests alternation, which is dependent on P9-04. Pump requests for alternation when this shows 0 min.

G.11 Anti-No Flow Simplified Setup

◆ Sleep and Anti-No-Flow Detection Start-up Procedure

Note: Ensure the system is regulating properly under normal running conditions before adjusting Anti-No-Flow operation. If the system is stable, continue to Step 1 to verify no-flow/sleep operation. If the system is unstable, turn off the Anti-No-Flow function (P2-23 set to 0.00%) and adjust the PI-control parameters b5-02, b5-03 to stabilize system. Once the system is stable, re-enable the Anti-No-Flow function by setting P2-23 back to 0.40% and continue to Step 1 to verify no-flow/sleep operation.

1. Create a no-flow situation (e.g., close off the discharge valve) to verify that the system holds pressure.
2. Press the STOP button on the digital operator and wait 1 minute until the system stabilizes then verify system pressure feedback in U1-91. If the pressure drops more than 3 psi, adjust P2-25 to the actual delta pressure drop plus 1 psi.
Example: If the setpoint is 80 psi and U1-91 shows 76 psi then P2-25 should be $4 + 1 = 5$ psi. This sum value should always be more than the start level (P1-04). If this sum value is not more than the start level, the system pressure is not holding and should be corrected or the pump system will continue to cycle on and off.
3. Run system in normal automatic operation with flow and check monitor U1-99 to verify that the value is continuously incrementing and resetting back to zero. If the value holds at 10 seconds, increase P2-24 by increments of 5 seconds. Repeat this process each time P2-24 is adjusted.
4. Create a no-flow situation and ensure that U1-99 increments and holds at the time set in P2-24. When the Anti-No-Flow timer expires, the speed will gradually reduce until it reaches the minimum pump speed (P1-06). The speed will hold at the minimum pump speed for 5 seconds before going to sleep.
5. Run system in normal automatic operation and verify sleep and wake-up operation until reaching satisfactory system performance.

THIS PAGE INTENTIONALLY BLANK

iQpump Controller



YASKAWA ELECTRIC AMERICA, INC.
Chicago-Corporate Headquarters
2121 Norman Drive South, Waukegan, IL 60085, U.S.A.
Phone: (800) YASKAWA (800-927-5292) Fax: (847) 887-7310
Internet: <http://www.yaskawa.com>

YEA Document Number: TM.iQp.01 03/15/2009 Rev:09-03

Data subject to change without notice. Yaskawa Electric America, Inc.

