

- NOTES:**
- CONNECTED TO THE CABINET. CUSTOMER TO CONNECT THE CABINET GROUND LUGS TO EARTH GROUND AND UTILITY GROUND.
 - INSULATED TWISTED SHIELDED WIRE IS REQUIRED. SHIELD TO CONNECT TO PROPER TERMINAL AS SHOWN. CONNECT THE SHIELD ONLY AT THIS END. STUB AND ISOLATE THE OTHER END. DO NOT RUN THESE WIRES IN THE SAME CONDUIT AS THE AC POWER AND THE AC CONTROL WIRES. KEEP ALL WIRING UNDER 50mm IN LENGTH.
 - WITH A CONTROL TRANSFORMER, T1, POWER RATING 350VA OR GREATER, SECONDARY FUSE F6 IS ADDED.
 - WITHOUT THE INPUT CIRCUIT BREAKER OPTION PC, OR WHEN NOTED ON THE CABINET NAMEPLATE, BRANCH CIRCUIT PROTECTION MUST BE SUPPLIED BY THE INSTALLER.
 - CUSTOMER TO ADJUST THE THERMOSTAT ON THE SPACE HEATER HR1 FOR THE MINIMUM DESIRED TEMPERATURE INSIDE THE DRIVE CABINET. THIS SET TEMPERATURE IS NORMALLY SELECTED TO BE SLIGHTLY HIGHER THAN THE MINIMUM AMBIENT TEMPERATURE OF THE AIR SURROUNDING THE CABINET AND IS THE TEMPERATURE AT WHICH THE SPACE HEATER HR1 WILL SHUT OFF.
 - CONDUIT FITTINGS/HUBS SHALL COMPLY WITH THE 'STANDARD FOR CONDUIT, TUBING AND CABLE FITTINGS, UL 514B' OR CONDUIT FITTINGS HAVING THE SAME ENVIRONMENTAL RATING AS THE ENCLOSURE SHALL BE USED.
 - TERMINALS p1 AND n1 ARE FOR MOMENTARY POWER LOSS RECOVERY UNIT. DO NOT CONNECT TO AC POWER SUPPLY.
 - CUSTOMER TO REPLACE THE JUMPER WITH NORMALLY CLOSED SAFETY INTERLOCKS, IF APPLICABLE.

— - INDICATES COMPONENTS NOT SUPPLIED BY YASKAWA
 * - INDICATES CUSTOMER WIRING
 ⚡ - CONNECTED TO THE CABINET OR PANEL

SEE DRAWING UDE00538 FOR DRIVE PARAMETERS.
 SEE DRAWING UDE00539 FOR CUSTOMER CONNECTIONS.

YASKAWA

THIS DOCUMENT AND INFORMATION CONTAINED HEREIN IS CONFIDENTIAL AND CANNOT BE COPIED OR DISCLOSED IN WHOLE OR IN PART WITHOUT THE EXPRESS WRITTEN CONSENT OF YASKAWA AMERICA, INC.

REVISED BY	A. MEILAHN	DATE	01/05/17	REVISED BY	N. LAWS	DATE	02/10/17
DESIGNED BY	N. LAWS	DATE	02/15/17	DESIGNED BY	K. FLIERL	DATE	02/15/17
DRAWN BY	A. MEILAHN	DATE	01/05/17	DRAWN BY	A. MEILAHN	DATE	01/05/17

SCHEMATIC DIAGRAM OF U1000 IQPUMP CONFIGURED TYPE 3R, 240V

DS.Q1E3.10

REV.	DESCRIPTION	ECO #	DRAWN BY	DATE
01	FIXED CB1 CONNECTIONS	9683	N. LAWS	06/24/19
00	INITIAL RELEASE	---	A. MEILAHN	02/15/17

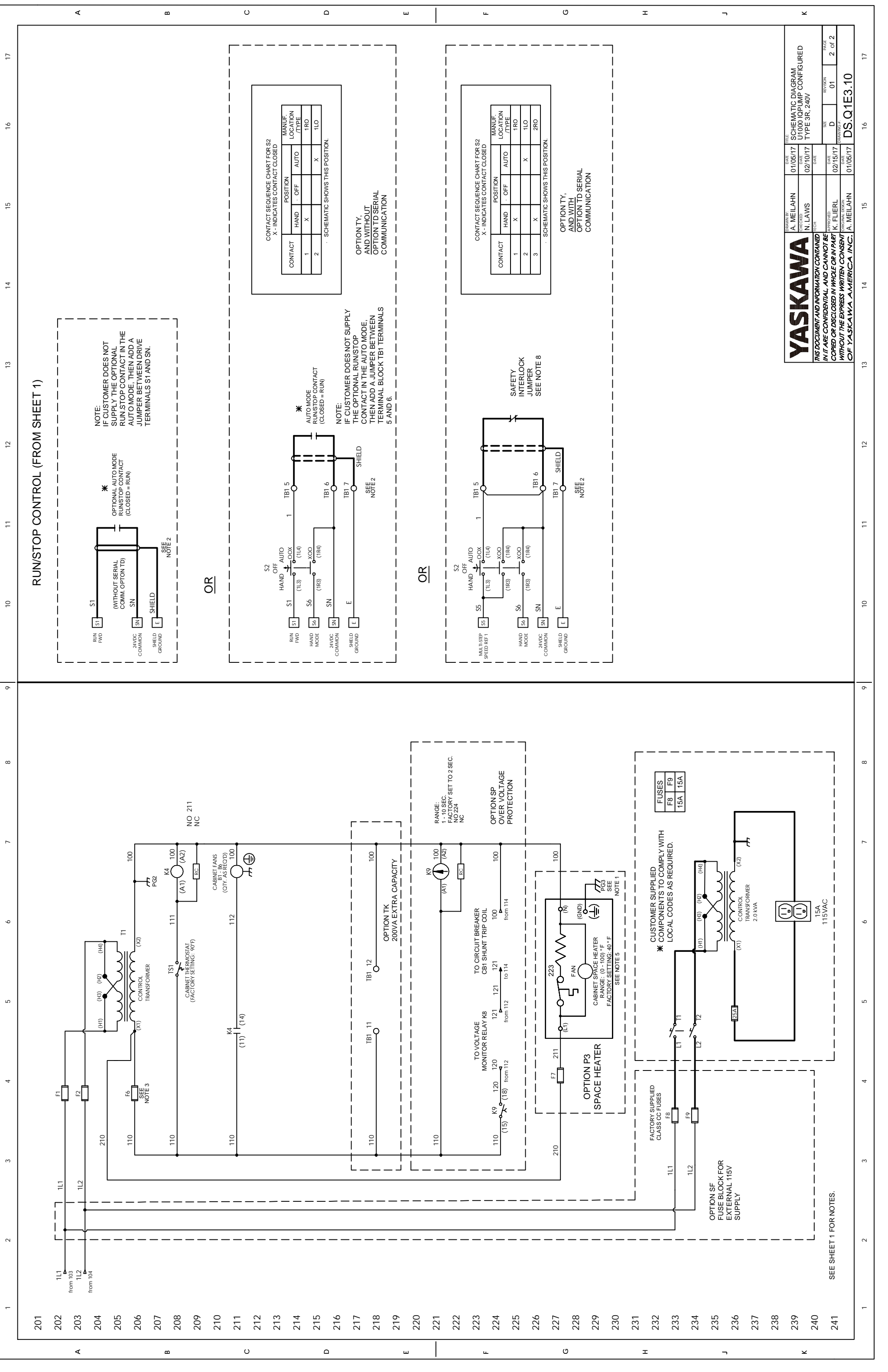

RUN/STOP CONTROL (FROM SHEET 1)

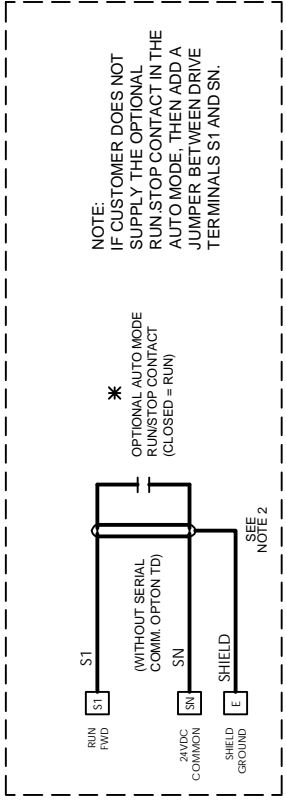

OR

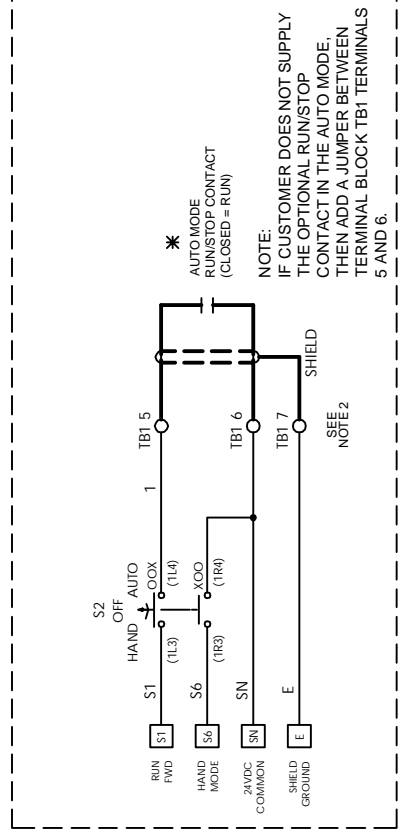

OR

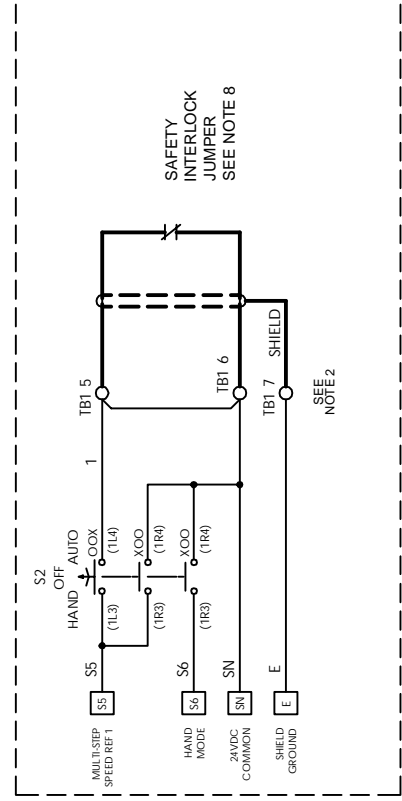

CONTACT SEQUENCE CHART FOR S2
X - INDICATES CONTACT CLOSED

CONTACT	POSITION		MANUF. LOCATION /TYPE
	HAND	AUTO	
1	X		1RO
2		X	1LO

OPTION TY. AND WITHOUT OPTION TD SERIAL COMMUNICATION

CONTACT SEQUENCE CHART FOR S2
X - INDICATES CONTACT CLOSED

CONTACT	POSITION		MANUF. LOCATION /TYPE
	HAND	AUTO	
1	X		1RO
2		X	1LO
3	X		2RO

OPTION TY. AND WITH OPTION TD SERIAL COMMUNICATION

FUSES

F8	F9
15A	15A

SEE SHEET 1 FOR NOTES.

YASKAWA

THIS DOCUMENT AND INFORMATION CONTAINED IN IT ARE CONFIDENTIAL AND CANNOT BE COPIED OR DISCLOSED IN WHOLE OR IN PART WITHOUT THE EXPRESS WRITTEN CONSENT OF YASKAWA AMERICA, INC.

DESIGNED BY	A. MEILAHN	DATE	01/05/17	REV.	SCHEMATIC DIAGRAM
DESIGNED BY	N. LAWS	DATE	02/10/17	REV.	SCHEMATIC DIAGRAM
DESIGNED BY	K. FLIERL	DATE	02/15/17	REV.	SCHEMATIC DIAGRAM
DESIGNED BY	A. MEILAHN	DATE	01/05/17	REV.	SCHEMATIC DIAGRAM

TYPE 3R, 240V

SIZE: D

DATE: 01

PAGE: 2 of 2

DRAWING #: DS.Q1E3.10